

ROLLER GUIDE UNIT WITHOUT DRIVE

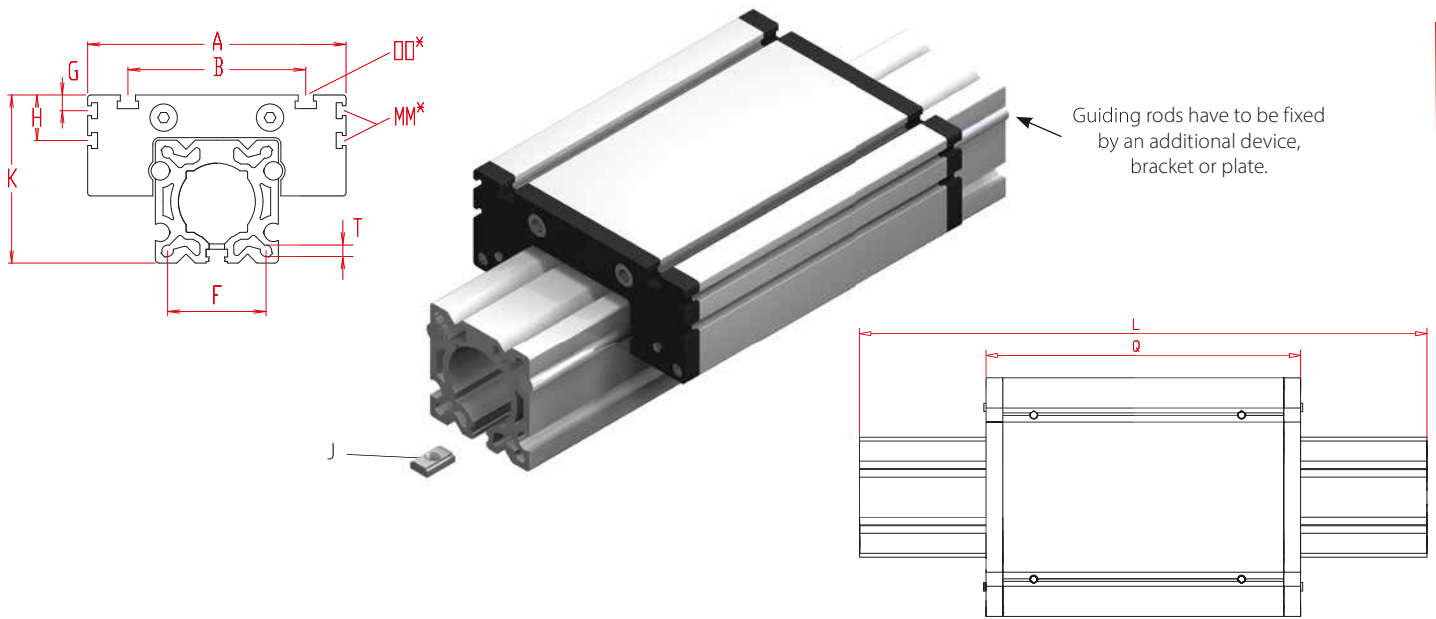

2.1

\*For slide nuts refer to chapter 2.2 page 2

Increasing the carriage length will increase the basic length by the same amount.

Size □	Basic length L	A	B	F	G	H	J	K	MM for	OO for	Q	T	Basic weight	Weight per 100 mm
ER 30	86	70	56	23	-	-	M 6	41	-	M 6	82	M 4	0,5 kg	0,12 kg
ER 40	126	100	66	29	-	-	M 6 - M10	55	-	M 6	122	M 5	0,7 kg	0,23 kg
ER 60	172	144	96	48	--	-	M 6 - M10	79	-	M 8	168	M 6	2,4 kg	0,61 kg
ER 60S	198	170	108	48	--	-	M 6 - M10	83	-	M 8	194	M 6	3,4 kg	0,61 kg
ER 80	198	170	117	64	10,5	30,5	M 6 - M10	110	M 6	M 10	194	M 8	3,7 kg	0,90 kg
ER 80S	218	190	126	64	12,5	30	M 6 - M10	111	M 6	M 8	214	M 8	4,7 kg	0,90 kg
ER 100	304	230	155	80	-	29	M 10	139	M 10	M 10	300	M 10	10,8 kg	1,50 kg
ER 125	369	295	200	100	-	30	M 12	170	M 10	M 12	365	M 12	20,3 kg	2,05 kg

- 0** Choice of guide body profile:
  - (0) Standard (2) corrosion-protected guide rods and screws
  - (4) expanded corrosion-protected version (depending on the availability of components)

**0** Choice of carriages:

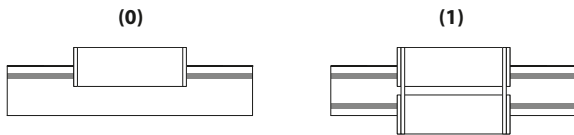

Size	Version 1	
	Q	L
30	94	98
40	138	142
60	184	188
60S	214	218
80	210	214
80S	234	238
100	316	320
125	389	393

**Application:**

This unit can be used as a load-carrying linear slide, or it may be fitted with a suitable pneumatic drive.

**ER 40 0 0 0 0 0 0 0 1500** — Basic length + stroke = total length  
 Pos. 1 2 3 4 5 6 7

For combination kits and connecting elements refer to chapter 2.2

Sample ordering code:  
 ER 40, Non driven system, standard body profile, standard carriage, 1374 mm stroke