

Linear system **LLZ 40, 60, 80, 100**

BELT DRIVE

⊕ INDEPENDENT INSTALLATION POSITION

📏 LONG TRAVERSE PATH > 6000 MM

✔ INTERNAL GUIDE

☀ SIMPLE & SOLID



Function:

The guide body consists of an aluminium square profile, with an integrated roller guide. The carriage is moved by means of an internal rotating toothed belt. On one end there is a pulley block with coupling claws on both sides (standard version). On the opposite end there is a plate with a retensioning device for the toothed belt.

Fitting position:

As required. Max. length 6.000 mm without joints.

Carriage mounting:

By tapped holes.

Unit mounting:

By T-slots and mounting sets. The linear axis can be combined with any T-slot profile.

Belt performance:

HTD with steel reinforcement, no backlash when changing direction, repeatability ± 0,1 mm.

Carriage support:

The carriage runs on 5 rollers which can be adjusted and serviced at each central servicing position. Two grease nipples at the carriage enable relubrication of the positioning system.

11.1

Forces and torques	Size	40		60		80		100	
	Forces/Torques	static	dynamic	static	dynamic	static	dynamic	static	dynamic
F_x (N)		800	250	1073	960	1900	1800	4000	3800
F_y (N)		130	65	780	650	1900	1500	1900	1500
F_z (N)		400	210	1170	845	2100	1700	2100	1700
M_x (Nm)		3	1	20	13	85	60	85	60
M_y (Nm)		13	6	78	65	140	110	150	110
M_z (Nm)		24	12	52	39	110	90	120	90
All forces and torques related to the following:									
existing values $\frac{F_y}{F_{y_{dyn}}} + \frac{F_z}{F_{z_{dyn}}} + \frac{M_x}{M_{x_{dyn}}} + \frac{M_y}{M_{y_{dyn}}} + \frac{M_z}{M_{z_{dyn}}} \leq 1$									
table values $\frac{F_y}{F_{y_{dyn}}} + \frac{F_z}{F_{z_{dyn}}} + \frac{M_x}{M_{x_{dyn}}} + \frac{M_y}{M_{y_{dyn}}} + \frac{M_z}{M_{z_{dyn}}} \leq 1$									
No-load torque									
Nm		0,4		0,6		0,8		1,2	
Speed									
(m/s) max		4		6		10		10	
Geometrical moments of inertia of aluminium profile									
I_x mm ⁴		1,01x10 ⁵		4,47x10 ⁵		15,83x10 ⁵		35,51x10 ⁵	
I_y mm ⁴		1,31x10 ⁵		5,59x10 ⁵		20,68x10 ⁵		46,41x10 ⁵	
Elastic modulus N/mm ²		70000		70000		70000		70000	

For life-time calculation of rollers use our homepage.

Driving torque:

$$M_o = \frac{F \cdot P \cdot S_i}{2000 \cdot \pi} + M_n$$

$$P_o = \frac{M_o \cdot n}{9550}$$

- F = force (N)
- P = pulley action perimeter (mm)
- S_i = safety factor 1,2 ... 2
- M_n = no-load torque (Nm)
- n = rpm pulley (min⁻¹)
- M_o = driving torque (Nm)
- P_o = motor power (KW)

Deflection:

$$f = \frac{F \cdot L^3}{E \cdot I \cdot 192}$$

- f = deflection (mm)
- F = load (N)
- L = free length (mm)
- E = elastic modulus 70000 (N/mm²)
- I = second moment of area (mm⁴)

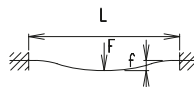

Linear system LLZ 40, 60, 80, 100

Dimensions (mm)

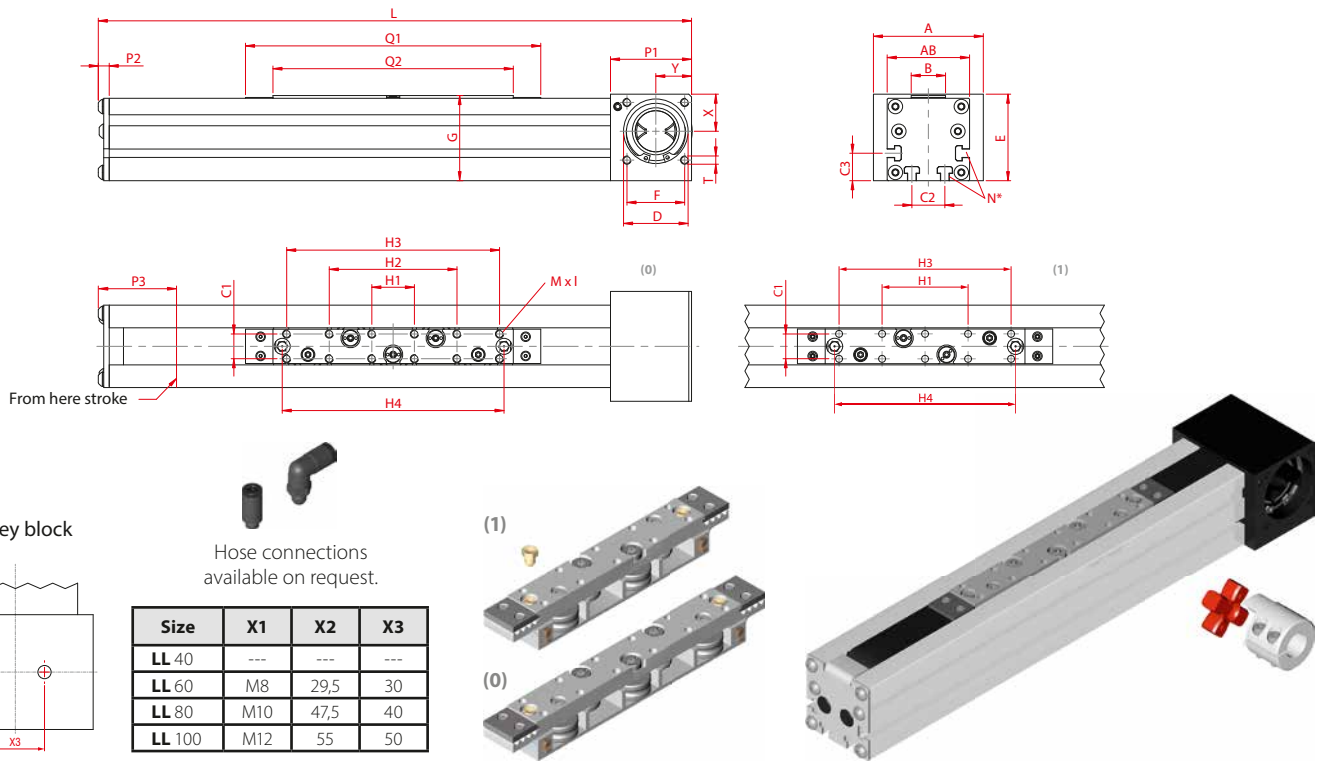

2 cupped-type lubricating nipples for each carriage

*For slide nuts refer to chapter 2.2 page 2

Size	Basic length L	A	AB	B	C1	C2	C3	D -0,05	E	F	G	M	N for	P1	P2	P3	T	X	Y	Basic weight	Weight per 100 mm
LLZ 40	222	52	40	15	10	12	14	28	41	25	42	M4x6	M4	36	4	34	M4	16	16	0,69 kg	0,22 kg
LLZ 60	330	80	60	25	18	24	20	47	63	42	62,5	M6x6	M5	59	6	55	M6	27	26	2,75 kg	0,41 kg
LLZ 80	495	100	80	25	18	30	22	68	93	60	83	M6x10	M6	90	9	84	M8	45	40	8,45 kg	0,90 kg
LLZ 100	540	130	100	42	26	40	30	90	110	80	103	M8x12	M8	110	11	109	M10	49,4	50	14,56 kg	1,18 kg

0 Choice of guide body profile:

- (0) Standard (2) corrosion-protected guide rods and screws
- (4) expanded corrosion-protected version (depending on the availability of components)

0 Choice of carriages:

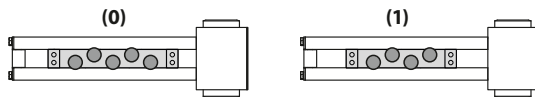

Carriage	L	Q1	Q2	H1	H2	H3	H4
LL 40 Vers. (0)	222	152	122	21	63	105	111
LL 40 Vers. (1)	200	130	100	42	---	84	90
LL 60 Vers. (0)	330	215	175	31	93	155	161,5
LL 60 Vers. (1)	299	184	144	62	---	124	130,5
LL 80 Vers. (0)	495	320	251	30	90	150	228
LL 80 Vers. (1)	435	260	191	40	---	120	168
LL 100 Vers. (0)	540	320	250	30	90	150	242
LL 100 Vers. (1)	481	261	191	30	90	150	183

0 Drive version:

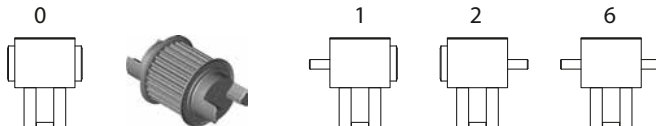

Belt table:

Code No.	Size	Belt	mm/rev.	Number of teeth
0 2	40	3M 20	75	25
0 3	60	5M 30	130	26
0 4	80	8M 30	176	22
0 7	100	8M 50	224	28

Shaft dimensions / Coupling claw:

Size	Shaft Ø h6 x length	Feather key	Coupling
40	6 x 15	2x2x12	7
60	14 x 35	5x5x28	14
80	18 x 45	6x6x40	19
100	22 h6 x 45	6x6x40	24

LLZ 60 1 0 0 0 0 3 1 1500 — Basic length + stroke = total length
Pos. 1 2 3 4 5 6 7

Sample ordering code:
LLZ60, standard body profile, double-sided coupling claw, 1170 mm stroke