

Linear system **EGT/EGK 30, 40, 60, 80**

1.1 SPINDLE DRIVEN

▷◁ SLIDE UNIT

🛡️ PRECISION

🔧 ROBUST

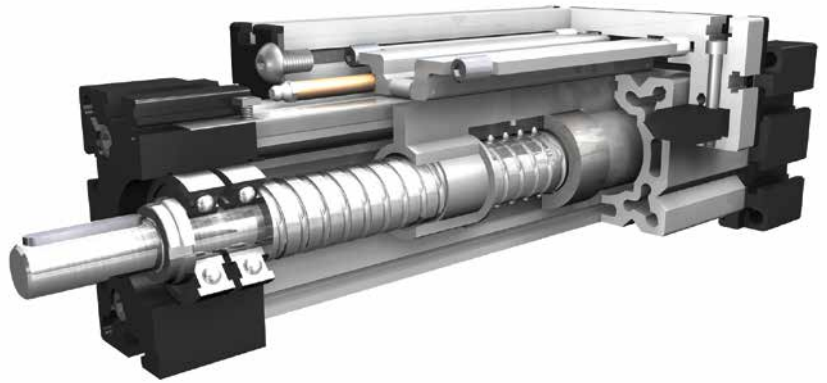
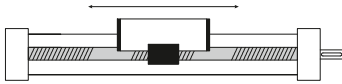

Function:

This unit consists of an aluminium square profile with lateral V-guides. The carriage, which is driven by means of a trapezoidal/ballscrew threaded spindle with lead screw, moves along the unit guided by V-slides that are adjustable free of play. Where two linear units are used in parallel or where two carriages are mounted on one unit, the leading-nut receiver can be used to adjust the symmetry of the carriages. The linear opening of the unit is sealed with a stainless steel cover band to make the unit splash-proof and dust-tight.

Fitting position:

As required. Max. length 3.000 mm (**EG 30** / max. 1500 mm, **EG 40** / max. 2000 mm)

Carriage mounting:

T-slots, tapped holes (size 40)

Unit mounting:

By T-slots or tapped holes in the bearing block, mounting sets.

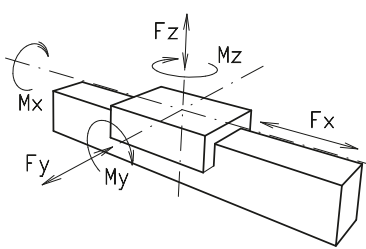
Forces and torques	Size	EG 30		EG 40		EG 60		EG 80	
	Forces / Torques	static	dynamic	static	dynamic	static	dynamic	static	dynamic
	F_x (N)	750	600	1500	1200	2500	2000	4200	3500
	F_y (N)	90	60	350	315	500	450	1000	900
	F_z (N)	90	60	500	450	750	675	1125	1000
	M_x (Nm)	10	5	20	18	33	30	82	75
	M_y (Nm)	13	6	44	40	77	70	220	200
	M_z (Nm)	14	7	33	30	55	50	165	150
All forces and torques relate to the following:									
existing values $\frac{F_y}{F_{y_{dyn}}} + \frac{F_z}{F_{z_{dyn}}} + \frac{M_x}{M_{x_{dyn}}} + \frac{M_y}{M_{y_{dyn}}} + \frac{M_z}{M_{z_{dyn}}} \leq 1$									
table values $\frac{F_y}{F_{y_{dyn}}} + \frac{F_z}{F_{z_{dyn}}} + \frac{M_x}{M_{x_{dyn}}} + \frac{M_y}{M_{y_{dyn}}} + \frac{M_z}{M_{z_{dyn}}} \leq 1$									
No-load torque									
	Trapezoidal thread	10x3	-	18x4	18x8	24x5	24x10	28x5	28x10
	(Nm)	0,4	-	0,70	0,70	0,50	0,80	0,80	1,0
	Ballscrew	8x2,5	-	16x5	16x10	25x5	25x10	32x5	32x10
	(Nm)	0,25	-	0,40	0,60	0,40	0,70	0,80	1,0
Geometrical moments of inertia of aluminium profile									
	I_x mm ⁴	4,09x10 ⁴		1,35x10 ⁵		5,65x10 ⁵		19,14x10 ⁵	
	I_y mm ⁴	4,00x10 ⁴		1,48x10 ⁵		6,12x10 ⁵		20,12x10 ⁵	
	Elastic-modulus N/mm ²	70000		70000		70000		70000	

Driving torque:

$$M_a = \frac{F \cdot P \cdot S_i \cdot w}{2000 \cdot \pi \cdot \mu} + M_n$$

$$P_a = \frac{M_a \cdot n}{9550}$$

F = force (N)
 P = thread pitch (mm)
 S_i = safety factor 1,2 ... 2
 M_n = no-load torque (Nm)
 n = rpm of screw (min⁻¹)
 M_a = driving torque (Nm)
 μ = screw efficiency
 w = friction coefficient ~1,22
 P_a = motor power (KW)

Efficiency of lead screws:

All ballscrew 0,900

Tr 10x3 0,375
 Tr 18x4 0,399
 Tr 18x8 0,565
 Tr 24x5 0,384
 Tr 24x10 0,550
 Tr 28x5 0,349
 Tr 28x10 0,513

Deflection:

$$f = \frac{F \cdot L^3}{E \cdot I \cdot 192}$$

f = deflection (mm)
 F = load (N)
 L = free length (mm)
 E = elastic modulus 70000 (N/mm²)
 I = second moment of area (mm⁴)

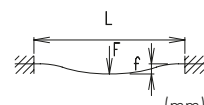

For the diagram for critical speeds of lead screws refer to chapter 4.2

Linear system EGT/EGK 30, 40, 60, 80

Dimensions (mm)

1.1

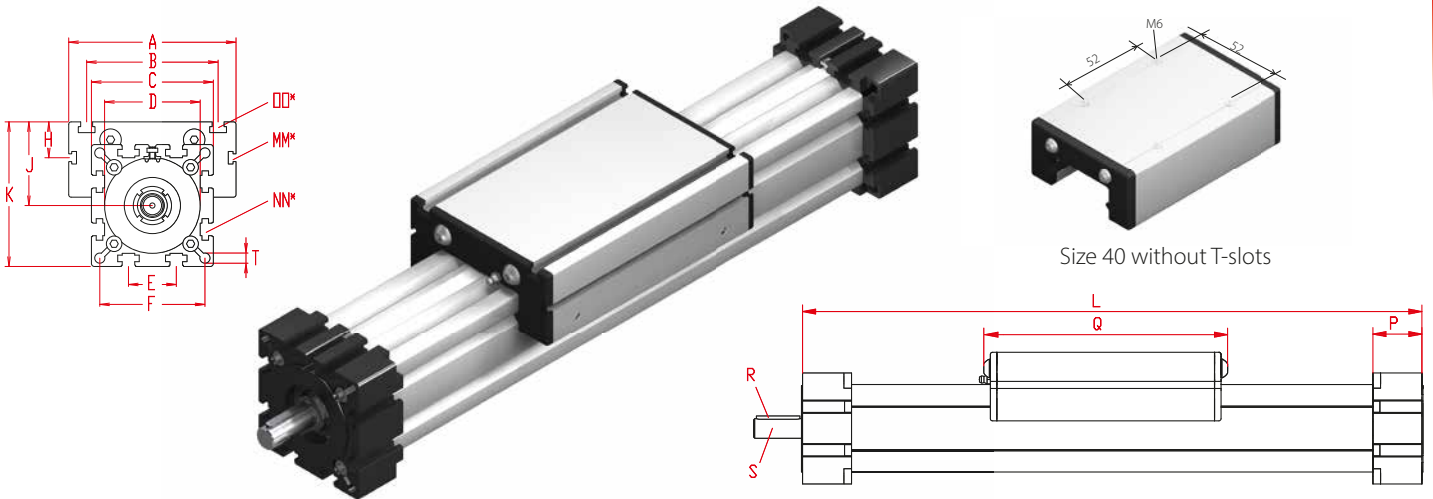

*For slide nuts refer to chapter 2.2 page 2

Increasing the carriage length will increase the basic length by the same amount.

Size	Basic length L	A	B	C	D ± 0,05	E	F	H	J	K	MM for	NN for	OO for	P	Q	R	S Ø h6 x length	T	Basic weight	Weight per 100 mm
EG 30	120	70	56	42	40x1	13	35	-	26	47	-	M 6	M 6	18	82	-	5x15	4,2	0,6 kg	0,16 kg
EG 40	170	70	-	58	48x1	18	47	-	35	64	-	M 6	M 6	25	117	3x3x25	10x27	6,5	1,3 kg	0,36 kg
EG 60	235	100	80	82	62x1	30	69	-	49	90	-	M 8	M 8	35	165	5x5x28	14x35	8,5	4,0 kg	0,67 kg
EG 80	286	140	110	102	80x1	40	88	30	70	121	M 6	M 10	M 10	45	193	6x6x40	18x45	8,5	6,7 kg	1,14 kg

T Spindle:
(T) Trapezoidal thread (K) Ballscrew

1 Selection of screw:
(1) right hand (2) left hand (Ballscrew by inquiry)

0 Choice of guide body profile:
(0) Standard (2) corrosion-protected guide rods (only size 30) and screws

0 Choice of carriages:

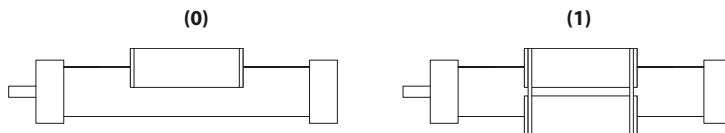

Size	Version 1	
	Q	L
30	94	132
40	133	186
60	181	251
80	209	302

0 Drive version:
(0) one shaft (locating bearing side) (1) one shaft (non-locating bearing side) (2) shaft on both sides

0 Selection of screw: Tr = trapezoidal thread / Kg = ballscrew

Size	Standard	Multistart screw	Standard	Multistart screw
30	(0) Tr 10x3		(0) Kg 8x2,5	
40	(0) Tr 18x4	(1) Tr 18x8	(0) Kg 16x5	(1) Kg 16x10 (2) Kg 16x16
60	(0) Tr 24x5	(1) Tr 24x10	(0) Kg 25x5	(1) Kg 20x20 (2) Kg 25x10 (3) Kg 20x50
80	(0) Tr 28x5	(1) Tr 28x10	(0) Kg 32x5	(1) Kg 25x25 (2) Kg 32x10

0 Ballscrew pitch accuracy:
(0) 0,05 mm / 300 mm (Standard) (2) 0,025 mm / 300 mm

0 End play of ball nut:
(0) 0,04 mm (Standard), (1) < 0,02 mm, (2) 2% apply prestress

Repeatability:
± 0,2 mm Trapezoidal
± 0,025 mm Ballscrew

EG T 40 1 0 0 0 0 0 0 1500

Basic length + stroke = total length

Pos. 1 2 3 4 5 6 7

Sample ordering code:

EGT40, trapezoidal right hand thread, standard body profile, top carriage, one shaft (locating bearing side), spindle 18x4, 1331 mm stroke

For combination kits and connecting elements refer to chapter 2.2



Linear system **EGT/EGK 30, 40, 60, 80**

1.1

SPINDLE DRIVEN RIGHT-HAND AND LEFT-HAND

Size 40 without T-slots

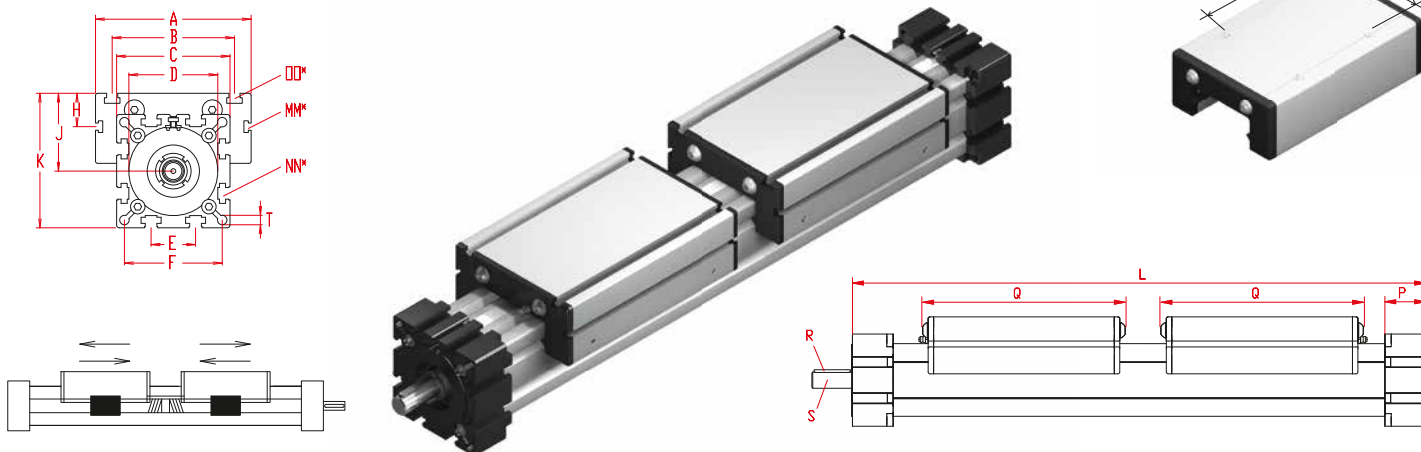

*For slide nuts refer to chapter 2.2 page 2

Increasing the carriage length will increase the basic length by the same amount.

Size	Basic length L	A	B	C	D ± 0,05	E	F	H	J	K	MM for	NN for	OO for	P	Q	R	S Ø h6 x length	T	Basic weight	Weight per 100 mm
EG 30	202	70	56	42	40x1	13	35	-	26	47	-	M 6	M 6	18	82	-	5x15	4,2	1,0 kg	0,16 kg
EG 40	287	70	-	58	48x1	18	47	-	35	64	-	M 6	M 6	25	117	3x3x25	10x27	6,5	2,5 kg	0,36 kg
EG 60	400	100	80	82	62x1	30	69	-	49	90	-	M 8	M 8	35	165	5x5x28	14x35	8,5	6,2 kg	0,67 kg
EG 80	479	140	110	102	80x1	40	88	30	70	121	M6	M 10	M 10	45	193	6x6x40	18x46	8,5	12,0 kg	1,14 kg

T Spindle:
(T) Trapezoidal thread (K) Ballscrew

3 Selection of screw:
(3) right - left hand (4) divided spindle

0 Choice of guide body profile:
(0) Standard (2) corrosion-protected guide rods (only size 30) and screws

0 Choice of carriages:

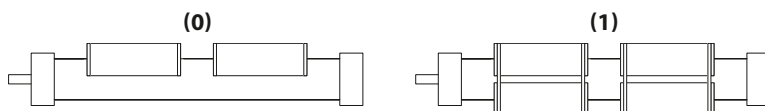

Size	Version 1	
	Q	L
30	94	226
40	133	319
60	181	432
80	209	511

0 Drive version:
(0) shaft right hand thread (1) shaft left hand thread (2) shaft on both sides

0 Selection of screw:

Size	Standard	Multistart screw	Standard	Multistart screw
30	(0) Tr 10x3		(0) Kg 8x2,5*	Tr = trapezoidal thread / Kg = ballscrew
40	(0) Tr 18x4	(1) Tr 18x8	(0) Kg 16x5	(1) Kg 16x10* (1) Kg 16x16*
60	(0) Tr 24x5	(1) Tr 24x10	(0) Kg 25x5	(1) Kg 20x20* (2) Kg 25x10*
80	(0) Tr 28x5	(1) Tr 28x10	(0) Kg 32x5	(1) Kg 25x25* (2) Kg 32x10*

* = only for selection of divided spindle

0 Ballscrew pitch accuracy:
(0) 0,05 mm / 300 mm (Standard) (2) 0,025 mm / 300 mm

0 End play of ball nut:
(0) 0,04 mm (Standard), (1) < 0,02 mm, (2) 2% apply prestress

Repeatability:
± 0,2 mm Trapezoidal
± 0,025 mm Ballscrew

EG T 40 3 0 0 0 0 0 2200 Basic length + stroke = total length
Pos. 1 2 3 4 5 6 7

For combination kits and connecting elements refer to chapter 2.2

Sample ordering code:
EGT40, trapezoidal right - left hand thread, standard body profile, 2 top carriage, one shaft on right hand side, spindle 18x4, 1914 mm stroke