

Linear system **DSZS 120, 160, 200**

BELT DRIVE

⊕ INDEPENDENT INSTALLATION POSITION

Ω OMEGA SYSTEM

⊞ LIFTING SYSTEM

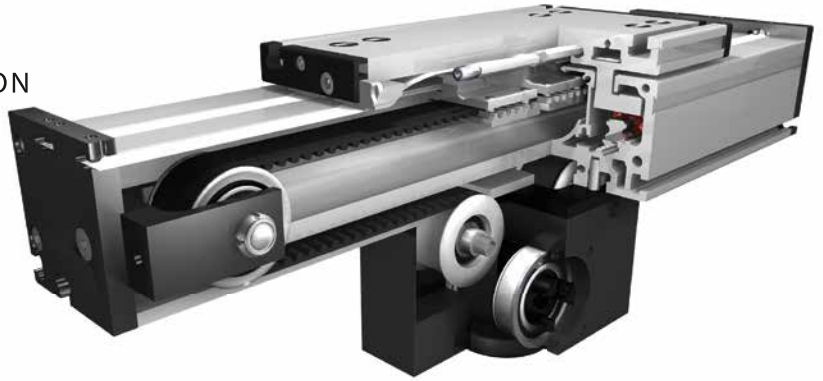
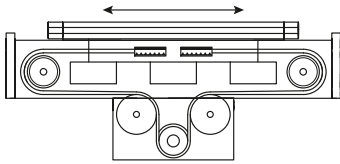

Function:

This unit consists of a rectangular aluminium profile with 2 integrated rail guides. The carriage is moved by a belt drive. An innovation is that the toothed belt is diverted within a drive block positioned centrally. The result is an enormous compactness with regard to the overall system length. The toothed drive pulley has a coupling claw in the standard version. Belt tension can be readjusted by a simple screw adjustment device in the carriage. This device can also be used for symmetrical adjustment of two or more linear units running parallel. The openings of the guide body are sealed with 3 stainless steel cover bands to protect the guide from splash water and dust. Alternatively, the opening can also be delivered without cover bands.

Fitting position:

As required. Max. length 6.000 mm without joints.

Carriage mounting:

By T-slots.

Unit mounting:

By T-slots and mounting sets. The linear axis can be combined with any T-slot profile.

Belt type:

HTD with steel reinforcement, no backlash when changing direction, repeatability $\pm 0,1$ mm.

Carriage support:

In the standard version, the carriage runs on 4 runner blocks which can be serviced at a central servicing position. For longer carriages the number of runner blocks can be increased.

9.1

Forces and torques	Size	160		200	
	permitted dyn. Forces*	5000 km	10000 km	5000 km	10000 km
F_x (N)		1900	1800	4000	3800
F_y (N)		5570	3900	15600	11080
F_z (N)		7050	5020	20600	14600
M_x (Nm)		358	255	1285	915
M_y (Nm)		369	262	1375	980
M_z (Nm)		364	258	1345	960
All forces and torques related to the following:					
existing values	$\frac{F_y}{F_{y_{dyn}}} + \frac{F_z}{F_{z_{dyn}}} + \frac{M_x}{M_{x_{dyn}}} + \frac{M_y}{M_{y_{dyn}}} + \frac{M_z}{M_{z_{dyn}}} \leq 1$				
table values					
No-load torque					
Nm without cover bands		1,5		2,0	
Nm with cover bands		2,1		4	
Speed					
(m/s) max		5		5	
Tensile force					
permanent (N)		1900		4000	
0,2 s (N)		2090		4300	
Geometrical moments of inertia of aluminium profile					
I_x mm ⁴		21,32x10 ⁵		4,81 x10 ⁶	
I_y mm ⁴		123,36x10 ⁵		26,0 x10 ⁶	
Elastic modulus N/mm ²		70000		70000	

For life-time calculation use our homepage.

* referred to life-time

Driving torque:

$$M_o = \frac{F \cdot P \cdot S_i}{2000 \cdot \pi} + M_n$$

$$P_o = \frac{M_o \cdot n}{9550}$$

F = force (N)
 P = pulley action perimeter (mm)
 S_i = safety factor 1,2 ... 2
 M_n = no-load torque (Nm)
 n = rpm pulley (min⁻¹)
 M_o = driving torque (Nm)
 P_o = motor power (KW)

Deflection:

$$f = \frac{F \cdot L^3}{E \cdot I \cdot 192}$$

f = deflection (mm)
 F = load (N)
 L = free length (mm)
 E = elastic modulus 70000 (N/mm²)
 I = second moment of area (mm⁴)

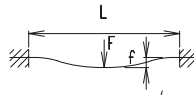

Linear system DSZS 120, 160, 200

Dimensions (mm)

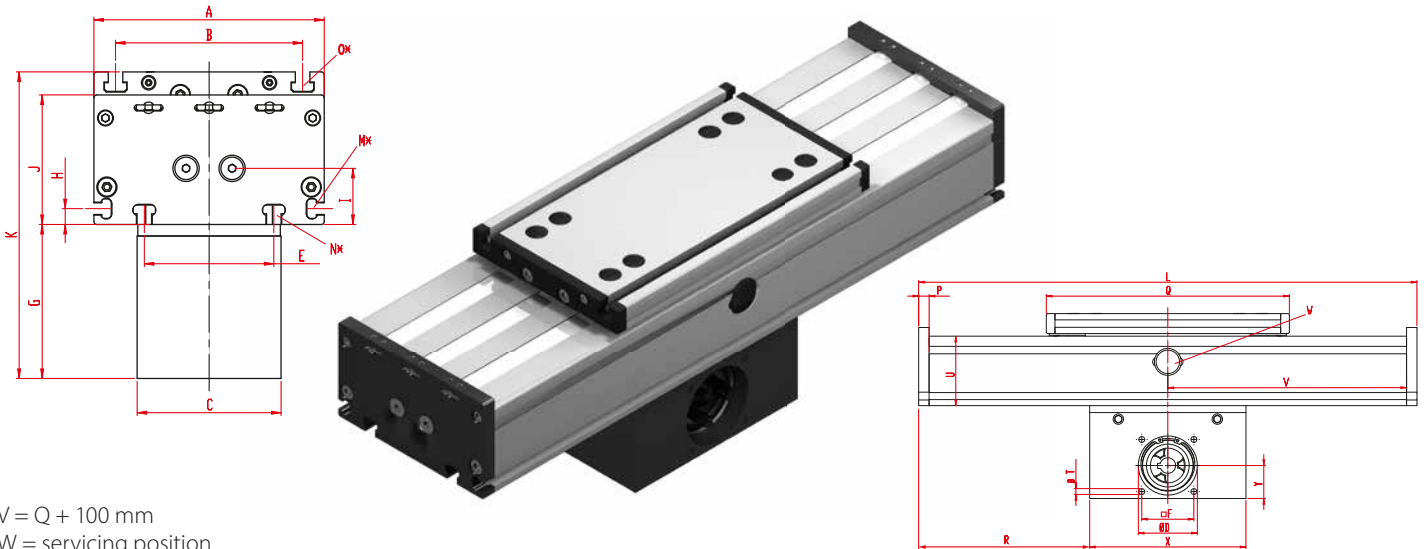

V = Q + 100 mm
W = servicing position

*For slide nuts refer to chapter 2.2 page 2

Increasing the carriage length will increase the basic length by the same amount.

Size	Basic length	A	B	C	D -0,05	E	F	G	H	I	J	K	M for	N for	O for	P	Q	R	T	U	X	Y	Basic weight	Weight per 100 mm
DSZS 120	230	120	96	80	47	78	42	84,5	10	28,7	68	167	M5	M6	M6	10	176	50	M6	60	130	30	6,2 kg	0,9 kg
DSZS 160	310	160	130	100	68	90	60	107	11	39	90	213	M6	M8	M8	12	280	65	M8	80	180	39	23,0 kg	1,9 kg
DSZS 200	380	200	160	130	90	140	80	146	15	48,5	110	275	M8	M10	M10	15	340	60	M10	100	270	60	33,0 kg	2,4 kg

0 Choice of guide body profile: Stainless versions upon request.

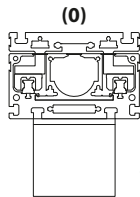

internal profile with cover bands

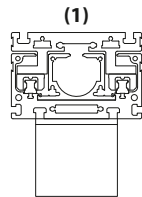

internal profile without cover bands

0 Choice of carriages:

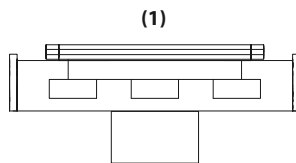
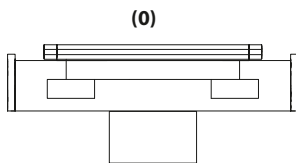

Size	Version 0		Version 1	
	Q	L	Q	L
120	156	230	156	230
160	280	310	280	310
200	340	380	380	420

0 Drive version:

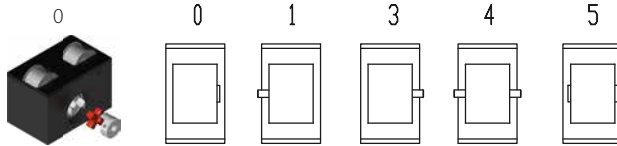

5 is as 0, but with coupling claws on both sides.
The standard version is supplied without shaft. A shaft can be retrofitted by inserting it into the pulley bore and securing it with 2 locking rings or tension sets (size 200).

Belt table:

Code No.	Size	Belt	mm/rev.	Number of teeth
0 4	120	5M 25	130	26
0 7	160	8M 30	192	24
0 9	200	8M 50	256	32

Shaft dimensions / Coupling claw:

Size	Shaft ø h6 x length	Key	Coupling
120	14 x 35	5x5x28	14
160	18 x 45	6x6x40	19
200	22 x 45	6x6x40	24

DSZS 160 1 0 0 0 7 1 1500

Basic length + stroke = total length

Pos. 1 2 3 4 5 6 7

Sample ordering code:

DSZS160 with internal profile and cover bands, standard carriage, coupling claw on one side, 1190 mm stroke.

