



Drives and automation

Drives and automation

One partner. All the possibilities.

STOBER has developed and produced excellent drive technology since 1934 and is active internationally with around 800 employees at 14 locations. STOBER impresses machine manufacturers in wide-ranging industries and markets around the world with tailor-made, highly efficient drive systems for demanding movements.



"Our vision is to be the preferred partner for perfect movement."

- Andreas Thiel, CEO of STÖBER Antriebstechnik.

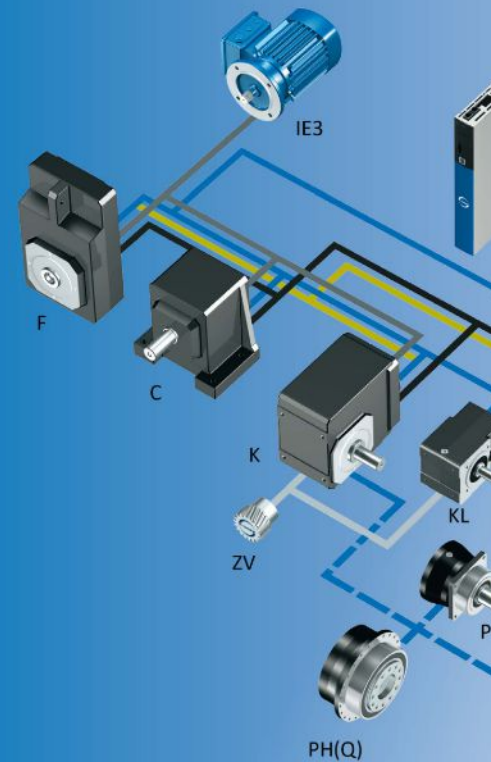

Drives and automation – what you can expect!

This product catalog presents a perfectly coordinated STOBER system consisting of electronics and motors, connected via ready-to-use STOBER cable technology.

Drive controllers of the 5th and 6th drive controller generation in combination with our highly dynamic synchronous servo motors: a perfect portfolio!

At home in the world of demanding motion

Gear units

Geared motors

Motors

Cables and drive controllers

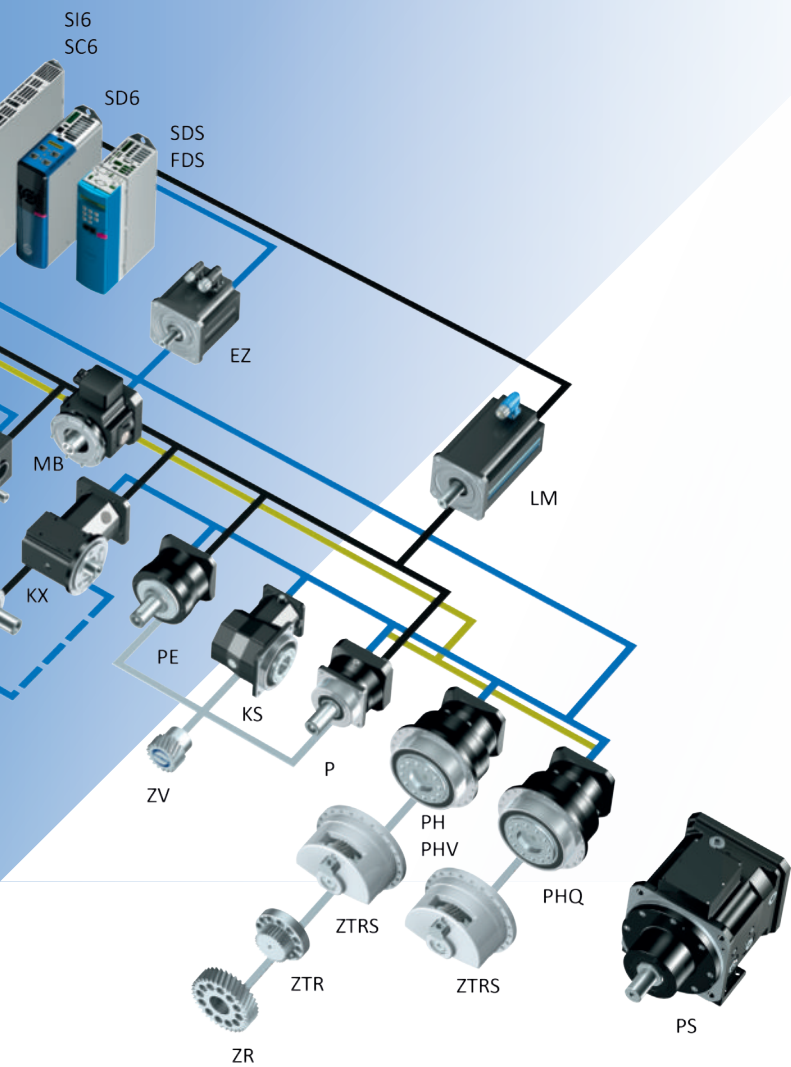

Everything from a single source.

The STOBER drive system consisting of gear units, motors, cables and drive controllers has a modular design and is freely scalable—for tailor-made, compact and powerful machine concepts. It can be adapted to your individual requirements and combined as needed in nearly all industries and applications areas.

We check every single component and how it works together with others, taking on the responsibility for the complete drive train. For you, this means that one contact partner, certified operating safety and maximum availability are guaranteed.

Need special solutions?

Numerous one-of-a-kind product highlights and project-related adjustments make it possible. With a holistic approach to your specific task, we work together on individualized solutions that are optimally coordinated to your requirements. Dedicated and solution-oriented in the support of your visions and projects.

STOBER moves integrally and precisely.



"We put ideas in motion with passion and a great deal of dedication. In the process, we rely on our decades of experience and an exceptionally broad range of products. Our customers benefit from precise, practical system solutions with uncompromising quality and expert individual consultation."

- Patrick Stöber, CEO of STÖBER Antriebstechnik.



STOBER moves as a team and with personality.

As a family-owned company, close relationships are extremely important to us. We build relationships with our employees, customers, and partners based on trust. We put people first.

We advocate for our employees' well-being, see things from our customers' perspectives, and demonstrate personal commitment to our mutual success.



"We have installed gear units, motors and drive controllers from STOBER in nearly all our systems. STOBER supports us in new projects from the first stroke of a pencil in the design phase until commissioning. Our years of cooperation are shaped by openness and honesty and emanate a rather special spirit. The technical consulting, the support—that is real, experienced partnership"

- Jürgen Leicht, Managing Partner of Leicht Stanzautomation.



Working together. Worldwide. Successfully.

With an eye to the future, STOBER is facing the challenges of digitalization and investing in integrated solutions and a strong global production, sales and service presence. STOBER China was founded at the end of 2019. As a result, we are present in more than 40 countries around in the world with eleven subsidiaries and 80 service partners.



**STOBER drives
Systems technology
Taicang, China.**



Table of contents

■	1	Selection tool.....	9
■	2	SC6 drive controllers.....	19
■	3	SI6 Drive controllers.....	49
■	4	SD6 drive controllers.....	91
■	5	POSIDYN SDS 5000 servo inverters.....	133
■	6	Connection method	169
■	7	EZ synchronous servo motors	187
■	8	Close to customers around the world.....	230
■	9	Appendix	233

1 Selection tool

1.1 Drive controllers



SC6



SI6



SD6

Product chapter

Chapter number

[▶ 2](#)

[▶ 3](#)

[▶ 4](#)

Technical data

$I_{2N,PU}$	4.5 – 19 A	5 – 50 A	2.3 – 85 A
$I_{2N,PU}$	4 – 15 A	4.5 – 40 A	1.7 – 60 A
I_{2maxPU}	9.5 – 39.9 A	10.5 – 105 A	4.2 – 153 A
I_{2maxPU}	10 – 37.5 A	11.3 – 100 A	4.3 – 150 A

An explanation of the formula symbols can be found in the chapter [▶ 9.1](#).

Features

Optimal application area

Number of axes	1 – 4	> 4	1 – 8
Application	Drive Based	CiA 402, PROFIdrive	Drive Based Synchronous

Motor types

Lean motors	✓	✓	
Asynchronous motors	✓	✓	✓
Synchronous servo motors	✓	✓	✓
Linear motors			✓
Torque motors	✓	✓	✓

Encoder interfaces

EnDat 2.2 digital	✓	✓	✓
Incremental	✓	✓	✓
SSI	✓	✓	✓
Resolver	✓	✓	(✓)
Pulse/direction signals	✓	✓	(✓)
EnDat 2.1 sin/cos			(✓)
Sin/cos			(✓)
EnDat 3 (OCS)	✓	✓	

(✓): Terminal module required

Communication

Isochronic system bus (IGB motion bus)			✓
CANopen			(✓)
EtherCAT	✓	✓	(✓)
PROFINET	✓	✓	(✓)

(✓): Communication module required

1 Selection tool

1.1 Drive controllers



SC6



SI6



SD6

Product chapter

Chapter number

[2]

[3]

[4]

Features

Motor temperature sensor

PTC thermistor	✓	✓	✓
Pt1000 temperature sensor	(✓)	(✓)	✓
(✓): OCS required			

Safety functions

STO, SS1: SIL 3, PL e (cat. 4)	(✓)	(✓)	(✓)
SS2, SLS, SBC, SBT, SDI, SLI: SIL 3, PL e (cat. 4)			(✓)
(✓): Safety module required			

Terminals

			IO6	RI6	XI6
Digital inputs	8	8	(5)	(5)	(13)
Digital outputs	—	—	(2)	(2)	(10)
Analog inputs	—	—	(2)	(2)	(3)
Analog outputs	—	—	(2)	(2)	(2)
Expanded encoder support	—	—	—	(✓)	—

(x): Terminal module required

Features

Multi-axis drive system		✓	
Stand-alone	✓		✓
One Cable Solution (OCS)	✓	✓	
Double-axis controller available	✓	✓	
Live firmware update	✓	✓	✓
Display and keyboard			✓
Removable data storage	✓	✓	✓
DC link connection	✓	✓	✓

Applications

Torque/force mode	✓	✓	✓
Velocity mode	✓	✓	✓
Positioning mode	✓	✓	✓
Master/slave mode			✓
Interpolating mode	✓	✓	✓

Conformity

cULus	✓	✓	✓
CE	✓	✓	✓
UKCA	(In preparation)	(In preparation)	(In preparation)

1 Selection tool

1.1 Drive controllers



SDS 5000

Product chapter

Chapter number

[▶ 5\]](#)

Technical data

$I_{2N,PU}$	2.3 – 85 A
$I_{2N,PU}$	1.7 – 60 A
I_{2maxPU}	4.2 – 153 A
I_{2maxPU}	4.3 – 150 A

An explanation of the formula symbols can be found in the chapter [▶ 9.1](#).

Features

Optimal application area

Number of axes	1 – 8
Application	Drive Based Synchronous

Motor types

Asynchronous motors	✓
Synchronous servo motors	✓

Encoder interfaces

EnDat 2.1/2.2 digital	✓
Incremental	✓
SSI	✓
Resolver	(✓)
Pulse/direction signals	(✓)
EnDat 2.1 sin/cos	(✓)

(✓): Terminal module required

Communication

Isochronic system bus (IGB motion bus)	✓
CANopen	(✓)
EtherCAT	(✓)
PROFINET	(✓)
PROFIBUS DP	(✓)

(✓): Communication module required

Motor temperature sensor

PTC thermistor	✓
Pt1000 temperature sensor	✓

1 Selection tool

1.1 Drive controllers



SDS 5000

Product chapter

Chapter number

▶ 5]

Features

Safety functions

STO, SS1: SIL 3, PL e (cat. 3)

(✓)

(✓): Safety module required

Terminals

SEA 5001

REA 5001

XEA 5001

Digital inputs

(5)

(5)

(13)

Digital outputs

(2)

(2)

(10)

Analog inputs

(2)

(2)

(3)

Analog outputs

(2)

(2)

(2)

Expanded encoder support

—

(✓)

—

(x): Terminal module required

Features

Stand-alone

✓

Live firmware update

✓

Display and keyboard

✓

Removable data storage

✓

DC link connection

✓

Applications

Torque/force mode

✓

Velocity mode

✓

Positioning mode

✓

Master/slave mode

✓

Electronic cam disk

✓

Conformity

cULus

✓

CE

✓

UKCA

(In preparation)

1 Selection tool

1.2 Connection method



Product chapter

Cables

Chapter number

[6]

Power cables

Design	Motor plug connector size		
	con.15	con.23	con.40
Quick lock	✓		
speedtec quick lock		✓	✓

Power cores (3 + PE)	Brake cores	Temperature sensor cores	Cable Ø	Bending radius 1 (min.)	Bending radius 2 (min.)
4 × 1.0 mm ²	2 × 0.5 mm ²	2 × 0.34 mm ²	Max. 10.1 mm	101.0 mm	50.5 mm
4 × 1.5 mm ²	2 × 1.0 mm ²	2 × 0.5 mm ²	Max. 12.2 mm	122.0 mm	61.0 mm
4 × 2.5 mm ²	2 × 1.0 mm ²	2 × 1.0 mm ²	Max. 15.0 mm	150.0 mm	75.0 mm
4 × 4.0 mm ²	2 × 1.0 mm ²	2 × 0.75 mm ²	Max. 16.0 mm	160.0 mm	80.0 mm
4 × 6.0 mm ²	2 × 1.5 mm ²	2 × 1.0 mm ²	Max. 19.4 mm	194.0 mm	97.0 mm
4 × 10.0 mm ²	2 × 1.5 mm ²	2 × 1.0 mm ²	Max. 23.5 mm	235.0 mm	117.5 mm

Bending radius: 1 = free to move, 2 = fixed installation

Other	
Torsional stress	± 30°/m
Bending resistance	✓
Resistant to oil and chemicals	✓

1 Selection tool

1.2 Connection method



Cables

Product chapter

Chapter number

[6]

Encoder cables

Design		Motor plug connector size	
		con.15	con.17
Quick lock		✓	
speedtec quick lock			✓

Encoder		Motor plug connector size	
		con.15	con.17
EnDat 2.1/2.2 digital encoders		✓	✓
EnDat 2.1 sin/cos encoders		✓	✓
Resolver		✓	✓

Encoder	Supply cores	Pilot cores	Cable Ø	Bending radius 1 (min.)	Bending radius 2 (min.)
EnDat 2.1/2.2 digital	2 × 0.25 mm ²	3 × 2 × 0.14 mm ²	Max. 6.8 mm	68.0 mm	34.0 mm
Resolver	2 × 0.25 mm ²	3 × 2 × 0.14 mm ²	Max. 11.4 mm	114.0 mm	57.0 mm
EnDat 2.1 sin/cos	2 × 0.34 mm ²	2 × 2 × 0.25 mm ² + 4 × 2 × 0.14 mm ²	Max. 8.7 mm	87.0 mm	43.5 mm

Bending radius: 1 = free to move, 2 = fixed installation

Other	
Torsional stress	± 30°/m
Bending resistance	✓
Resistant to oil and chemicals	✓

1 Selection tool

1.2 Connection method



Product chapter

Cables

Chapter number

[6]

One Cable Solution EnDat 3

Design	Motor plug connector size
	con.23
speedtec quick lock	✓

Power cores (3 + PE)	Brake cores	Pilot cores	Cable Ø	Bending radius 1 (min.)	Bending radius 2 (min.)
----------------------	-------------	-------------	---------	-------------------------	-------------------------

OCS-Basic:

4 × 1.0 mm ²	2 × 0.75 mm ²	2 × AWG22	Max. 13.6 mm	136.0 mm	68.0 mm
4 × 1.5 mm ²	2 × 1.0 mm ²	2 × AWG22	Max. 13.7 mm	137.0 mm	68.5 mm

OCS-Advanced:

4 × 1.5 mm ²	2 × 0.75 mm ²	2 × AWG22	Max. 14.7 mm	147.0 mm	73.5 mm
4 × 2.5 mm ²	2 × 0.75 mm ²	2 × AWG22	Max. 16.8 mm	168.0 mm	84.0 mm

Bending radius: 1 = free to move, 2 = fixed installation

Other	
Torsional stress	± 30°/m
Bending resistance	✓
Resistant to oil and chemicals	✓

1 Selection tool

1.3 Synchronous servo motors



Product chapter

EZ

Chapter number

[7]

Technical data

M_N	0.89 – 77.2 Nm
M_0	0.95 – 94 Nm
Shaft design	
Solid shaft without feather key	✓
Flange hollow shaft	
Encoder	
EnDat 3 One Cable Solution (OCS)	✓
EnDat 2.2	✓
EnDat 2.1	✓
Resolver	✓
Cooling	
Convection cooling	✓
Forced ventilation	✓
Brake	
Permanent magnet holding brake	✓
Marks and test symbols	
CE	✓
cURus	✓
UKCA	✓

1 Selection tool

1.3 Synchronous servo motors

1 Selection tool

1.3 Synchronous servo motors

2 SC6 drive controllers

Table of contents

2.1	Overview	20
2.1.1	Features.....	21
2.1.2	Software components	22
2.1.3	Application training.....	23
2.2	Technical data	23
2.2.1	Type designation	23
2.2.2	Sizes.....	24
2.2.3	General technical data	25
2.2.4	Electrical data.....	26
2.2.5	Cycle times	32
2.2.6	Derating.....	32
2.2.7	Dimensions.....	34
2.2.8	Weight.....	34
2.2.9	Minimum clearances	35
2.3	Drive controller/motor combinations.....	36
2.4	Accessories	38
2.4.1	Safety technology.....	38
2.4.2	Communication	39
2.4.3	Terminal set.....	39
2.4.4	DC link connection.....	40
2.4.5	Braking resistor	41
2.4.6	Choke	45
2.4.7	Encoder battery module	47
2.4.8	HTL-to-TTL adapter.....	47
2.5	Further information	47
2.5.1	Directives and standards	47
2.5.2	Symbols, marks and test symbols	48
2.5.3	Additional documentation	48



2 Drive controllers

SC6

2.1 Overview

Our more compact version for the encoderless Lean motor

Features

- Single or double-axis controller with a nominal output current up to 19 A and 250% overload capacity
- Sensorless position control of STOBBER Lean motors
- Control of rotary synchronous servo motors, asynchronous motors and torque motors
- One Cable Solution EnDat 3
- Electronic motor nameplate via EnDat encoder interfaces
- Integrated EtherCAT or PROFINET communication
- STO safety technology using terminals or STO and SS1 using FSoE or PROFIsafe: SIL 3, PL e (Cat. 4)
- Integrated brake control
- Single-ended nominal power consumption on double-axis controllers for operation of motors with different power
- Energy supply through direct power supply
- Flexible DC link connection for multi-axis applications

2.1.1 Features

The compact stand-alone SC6 drive controller allows for sensorless control of Lean motors of the LM series. These motors provide energy efficiency at the performance level of synchronous servo motors. They also guarantee high investment protection, thanks to energy efficiency class IE5 and the corresponding higher efficiency compared to IE4 asynchronous motors. However, the SC6 can also be used in combination with asynchronous motors or synchronous servo motors with encoders (e.g. the EZ series). SC6 is available in three sizes with a nominal output current of up to 19 A: Sizes 0 and 1 as a double-axis controller, size 2 as a single-axis controller.

For STOBER synchronous servo motors, we recommended operation with the EnDat 2.2 digital encoder or as a One Cable Solution with EnDat 3. These encoder systems make it possible to attain the highest control quality. It is possible to perform motor parameterization automatically from the electronic motor name-plate.



The compact SC6 for Lean motors of the LM series

As small as a paperback

You save valuable space in your control cabinet because, with a width of just 45 mm, this drive controller is the most compact solution on the market. It offers all the features that a designer requires.

Quick DC-Link

The drive controllers have the option of a DC link connection. This technology makes it possible for the regenerative production of energy from one drive to be used as motor energy by another drive. The Quick DC-Link rear structure element has been developed to set up a reliable and efficient rail connection to the DC link connection. This optionally available accessory connects the DC links of the individual drive controllers by means of copper rails that can carry a load of up to 200 A. The rails can be attached without any tools using quick fastening clamps.

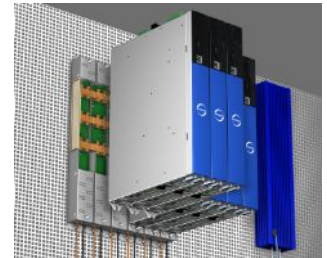

Perfectly adapted combinations

SC6 drive controllers can be combined with the STOBER SI6 and SD6 series as needed. For the general energy supply, the drive controllers from the SC6, SI6 and SD6 series are connected to each other using Quick DC-Link modules.

Tailored energy usage

When using double-axis modules, the unused power reserves of one axis can be used for other axes.

Precise dynamics

The drive controller provides acceleration that is literally as fast as lightning. For example, in conjunction with the STOBER EZ401 synchronous servo motor: from 0 to 3000 rpm in 10 ms.

Fewer clicks, less wiring

The installation of the drive controller is as easy as you could imagine. There is no difficult wiring. The encoder communication and power connection of the motor takes place using a common cable connection. The EnDat 3 encoder system provides an electronic motor nameplate that takes care of the parameterization of motor data simply and safely. EnDat 2.2 digital offers an alternative interface, which also has an electronic nameplate function.

**Safety functions**

The safety concept of the drive controller is based on the STO (Safe Torque Off) function. The concept corresponds to SIL 3 according to DIN EN 61800-5-2 and PL e (Cat. 4) according to DIN EN ISO 13849-1. For double-axis controllers, the STO safety function has a two-channel structure that acts upon both axes. For connection to a higher-level safety circuit, different interfaces are available (terminals, FSoE or PROFIsafe).

Heavy duty

There is an extremely robust design concealed behind the elegant exterior. All components—from the stable, well-shielded sheet steel housing to the motor connectors—far exceed the set values of industry standards. The inside is also anything but small-scale: ample computer capacities, high-quality components, careful workmanship.

2.1.2 Software components

Project configuration and commissioning

The 6th generation of DriveControlSuite project configuration and commissioning software has all the functions for the efficient use of drive controllers in single-axis and multi-axis applications. The program guides you step by step through the complete project configuration and parameterization process using wizards.

Open communication

The Ethernet-based EtherCAT and PROFINET fieldbus systems are available in the drive controller.

Applications

A drive-based application is recommended for the decentralized motion control of sophisticated machines. The drive-based application package from STOBER is the right choice wherever universal and flexible solutions are needed. The Drive Based application provides drive-based motion control for positioning, velocity and torque/force with the PLCopen Motion Control command set. These standard commands have been combined into operating modes for different applications and supplemented with additional functions such as motion block linking, cams and much more. For the command operating mode, all properties of the movements are specified directly by the controller. The properties of the movements in the drive are predefined in the motion block operating mode so that only a start signal is necessary to perform the movement. Linking can be used to define complete motion sequences. There is a separate operating mode available for applications controlled by velocity or torque/force such as pumps, fans or conveyor belts. This also allows for operation without a controller.

In addition, the CiA 402 and PROFIdrive applications are also available, which include both the controller-based and drive-based operating modes and application classes.

2.1.3 Application training

STOBER offers a multi-level training program that is essentially focused on the drive controller.

G6 Basic

Training content: System overview, installation and commissioning of the drive controller. Use of option modules. Parameterization, commissioning and diagnostics using the commissioning software. Remote maintenance. Basics of controller optimization. Configuration of the drive train. Integrated software functions. Software applications. Connection to a higher-level controller. Basics of safety technology. Practical exercises on training topics.

Software used: DriveControlSuite.

G6 Customized

Training content: Special knowledge for regulating, control and safety technology. Electronic cam disk. Practical exercises on training topics.

2.2 Technical data

Technical data for the drive controller can be found in the following chapters.

2.2.1 Type designation

SC	6	A	0	6	2	Z
----	---	---	---	---	---	---

Tab. 1: Example code for type designation

Code	Designation	Design
SC	Series	
6	Generation	Generation 6
A	Version	
0 – 2	Size	
6	Power output stage	Power output stage within the size
2	Axis controller	Double-axis controller
1		Single-axis controller
Z	Safety technology	SZ6: Without safety technology
R		SR6: STO using terminals
U		SU6: STO and SS1 using PROFIsafe
Y		SY6: STO and SS1 using FSoE

Tab. 2: Meaning of the example code

2.2.2 Sizes

Type	ID No.	Size	Axis controller
SC6A062	56690	Size 0	Double-axis controller
SC6A162	56691	Size 1	Double-axis controller
SC6A261	56692	Size 2	Single-axis controller

Tab. 3: Available SC6 types and sizes



SC6 in sizes 0 to 2

Note that the basic device is delivered without terminals. Suitable terminal sets are available separately for each size.

2.2.3 General technical data

The following information applies to all device types.

Device features	
Protection class of the device	IP20
Protection class of the installation space	At least IP54
Protection class	Protection class I in accordance with EN 61140
Radio interference suppression	Integrated line filter in accordance with EN 61800-3, interference emission class C3
Overvoltage category	III in accordance with EN 61800-5-1
Test symbols	CE, cULus, RoHS

Tab. 4: Device features

Transport and storage conditions	
Storage/transport temperature	-20 °C to +70 °C Maximum change: 20 K/h
Relative humidity	Maximum relative humidity 85%, non-condensing
Vibration (transport) in accordance with EN 60068-2-6	5 Hz ≤ f ≤ 9 Hz: 3.5 mm 9 Hz ≤ f ≤ 200 Hz: 10 m/s ² 200 Hz ≤ f ≤ 500 Hz: 15 m/s ²
Fall height for freefall ¹ Weight < 100 kg in accordance with EN 61800-2 (or IEC 60721-3-2, class 2M1)	0.25 m

Tab. 5: Transport and storage conditions

Operating conditions	
Surrounding temperature during operation	0 °C to 45 °C with nominal data 45 °C to 55 °C with derating -2.5% / K
Relative humidity	Maximum relative humidity 85%, non-condensing
Installation altitude	0 m to 1000 m above sea level without restrictions 1000 m to 2000 m above sea level with -1.5%/100 m derating
Pollution degree	Pollution degree 2 in accordance with EN 50178
Ventilation	Installed fan
Vibration (operation) in accordance with EN 60068-2-6	5 Hz ≤ f ≤ 9 Hz: 0.35 mm 9 Hz ≤ f ≤ 200 Hz: 1 m/s ²

Tab. 6: Operating conditions

Discharge times	
Self-discharge of DC link	15 min

Tab. 7: Discharge times of the DC link circuit

¹Only valid for components in original packaging

2.2.4 Electrical data

The electrical data of the available SC6 sizes as well as the properties of the brake chopper can be found in the following sections.

Information

For the time span between energizing two devices, note that:

- Direct, repeat activation of the supply voltage is possible for cyclical power-on/power-off operation.
- A time span of > 15 minutes must be observed between two energizing processes during continuous, cyclical power-on/power-off operation with increased charging capacity.

Information

The STO safety function is available for safe stopping as an alternative to continuous, cyclical power-on/power-off operation.

An explanation of the symbols used for formulas can be found in Chapter [\[9.1 \]](#).

2.2.4.1 Control unit

Electrical data	All types
U_{1CU}	24 V _{DC} +20%/–15%
I_{1maxCU}	0.5 A

Tab. 8: Control unit electrical data

2.2.4.2 Power unit: Size 0

Electrical data	SC6A062
U_{1PU}	$3 \times 400 V_{AC}$, +32% / -50%, 50/60 Hz; $3 \times 480 V_{AC}$, +10% / -58%, 50/60 Hz
f_{2PU}	0 – 700 Hz
U_{2PU}	0 – max. U_{1PU}
$U_{2PU,ZK}$	$\sqrt{2} \times U_{1PU}$
C_{PU}	270 μ F
$C_{N,PU}$	1400 μ F
C_{maxPU}	1880 μ F

Tab. 9: SC6 electrical data, size 0

The charging capacity depends on the time between two energizing processes:

Information

For the maximum charging capacity C_{maxPU} , a time span of ≥ 15 min must be maintained between two energizing processes.

Nominal currents up to +45 °C (in the control cabinet)

Electrical data	SC6A062
$f_{PWM,PU}$	4 kHz
$I_{1N,PU}$	10 A
$I_{2N,PU}$	2×4.5 A
I_{2maxPU}	210% for 2 s; 150% for 30 s

Tab. 10: SC6 electrical data, size 0, for 4 kHz clock frequency

Electrical data	SC6A062
$f_{PWM,PU}$	8 kHz
$I_{1N,PU}$	8.9 A
$I_{2N,PU}$	2×4 A
I_{2maxPU}	250% for 2 s; 200% for 5 s

Tab. 11: SC6 electrical data, size 0, for 8 kHz clock frequency

Electrical data	SC6A062
U_{onCH}	780 – 800 V_{DC}
U_{offCH}	740 – 760 V_{DC}
R_{2minRB}	100 Ω
P_{maxRB}	6.4 kW
P_{effRB}	2.9 kW

Tab. 12: Brake chopper electrical data, size 0

2.2.4.3 Power unit: Size 1

Electrical data	SC6A162
U_{1PU}	$3 \times 400 V_{AC}$, +32% / -50%, 50/60 Hz; $3 \times 480 V_{AC}$, +10% / -58%, 50/60 Hz
f_{2PU}	0 – 700 Hz
U_{2PU}	0 – max. U_{1PU}
$U_{2PU,ZK}$	$\sqrt{2} \times U_{1PU}$
C_{PU}	940 μ F
$C_{N,PU}$	1400 μ F
C_{maxPU}	1880 μ F

Tab. 13: SC6 electrical data, size 1

The charging capacity depends on the time between two energizing processes:

Information

For the maximum charging capacity C_{maxPU} , a time span of ≥ 15 min must be maintained between two energizing processes.

Nominal currents up to +45 °C (in the control cabinet)

Electrical data	SC6A162
$f_{PWM,PU}$	4 kHz
$I_{1N,PU}$	23.2 A
$I_{2N,PU}$	2×10 A
I_{2maxPU}	210% for 2 s; 150% for 30 s

Tab. 14: SC6 electrical data, size 1, for 4 kHz clock frequency

Electrical data	SC6A162
$f_{PWM,PU}$	8 kHz
$I_{1N,PU}$	20.9 A
$I_{2N,PU}$	2×9 A
I_{2maxPU}	250% for 2 s; 200% for 5 s

Tab. 15: SC6 electrical data, size 1, for 8 kHz clock frequency

Electrical data	SC6A162
U_{onCH}	780 – 800 V_{DC}
U_{offCH}	740 – 760 V_{DC}
R_{2minRB}	47 Ω
P_{maxRB}	13.6 kW
P_{effRB}	6.2 kW

Tab. 16: Brake chopper electrical data, size 1

2.2.4.4 Power unit: Size 2

Electrical data	SC6A261
U_{1PU}	$3 \times 400 V_{AC}$, +32% / -50%, 50/60 Hz; $3 \times 480 V_{AC}$, +10% / -58%, 50/60 Hz
f_{2PU}	0 – 700 Hz
U_{2PU}	0 – max. U_{1PU}
$U_{2PU,ZK}$	$\sqrt{2} \times U_{1PU}$
C_{PU}	940 μF
$C_{N,PU}$	1400 μF
C_{maxPU}	1880 μF

Tab. 17: SC6 electrical data, size 2

The charging capacity depends on the time between two energizing processes:

Information

For the maximum charging capacity C_{maxPU} , a time span of ≥ 15 min must be maintained between two energizing processes.

Nominal currents up to +45 °C (in the control cabinet)

Electrical data	SC6A261
$f_{PWM,PU}$	4 kHz
$I_{1N,PU}$	22.6 A
$I_{2N,PU}$	19 A
I_{2maxPU}	210% for 2 s; 150% for 30 s

Tab. 18: SC6 electrical data, size 2, for 4 kHz clock frequency

Electrical data	SC6A261
$f_{PWM,PU}$	8 kHz
$I_{1N,PU}$	17.9 A
$I_{2N,PU}$	15 A
I_{2maxPU}	250% for 2 s; 200% for 5 s

Tab. 19: SC6 electrical data, size 2, for 8 kHz clock frequency

Electrical data	SC6A261
U_{onCH}	780 – 800 V_{DC}
U_{offCH}	740 – 760 V_{DC}
R_{2minRB}	47 Ω
P_{maxRB}	13.6 kW
P_{effRB}	6.2 kW

Tab. 20: Brake chopper electrical data, size 2

2.2.4.5 DC link connection

The charging capacity of the drive controllers can be increased by a DC link connection only if the power grid supply is connected to all drive controllers simultaneously.

2.2.4.6 Single-ended nominal power consumption on double-axis controllers

Operating two motors on one double-axis controller makes it possible to operate one of the motors with a continuous current above the nominal current of the drive controller if the continuous current of the second connected motor is lower than the nominal current of the drive controller. This enables economical combinations of double-axis controllers and motors.

The nominal output current for axis B can be determined using the following formula if the output current for axis A is known:

Example 1

$$I_{2PU(B)} = I_{2N,PU} - (I_{2PU(A)} - I_{2N,PU}) \times \frac{3}{5} \quad \text{where} \quad 0 \leq I_{2PU(A)} \leq I_{2N,PU}$$

Example 2

$$I_{2PU(B)} = I_{2N,PU} - (I_{2PU(A)} - I_{2N,PU}) \times \frac{5}{3} \quad \text{where} \quad I_{2N,PU} \leq I_{2PU(A)} \leq 1,6 \times I_{2N,PU}$$

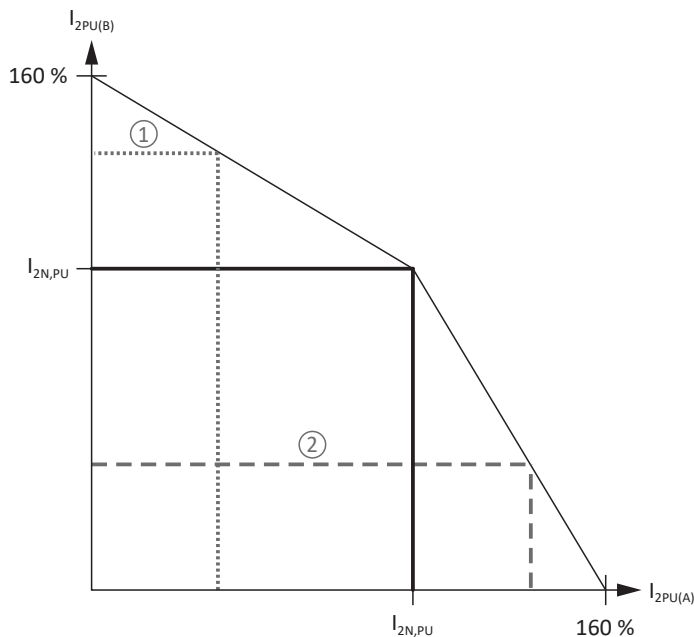

Fig. 1: Asymmetric load on double-axis controllers

Information

Note that the available maximum currents I_{2maxPU} of the axis controllers are also relative to the nominal output current $I_{2N,PU}$ for single-ended nominal power consumption.

2.2.4.7 Power loss data in accordance with EN 61800-9-2

Type	Nominal current $I_{2N,PU}$	Apparent power	Absolute losses $P_{V,CU}^2$	Operating points ³								IE class ⁴	Comparison ⁵
				(0/25)	(0/50)	(0/100)	(50/25)	(50/50)	(50/100)	(90/50)	(90/100)		
				Relative losses									
	[A]	[kVA]	[W]	[%]									
SC6A062	4.5	6.2	Max. 10	1.34	1.49	1.86	1.40	1.63	2.19	1.84	2.77	IE2	
SC6A162	10	13.9	Max. 10	0.76	0.92	1.43	0.81	1.04	1.75	1.22	2.29	IE2	
SC6A261	19	13.2	10	0.77	0.95	1.56	0.82	1.08	1.89	1.25	2.43	IE2	
				Absolute losses									
	[A]	[kVA]	[W]	P_V [W]									[%]
SC6A062	4.5	6.2	Max. 10	83.2	92.5	115.2	86.7	100.8	135.8	113.9	171.7	IE2	36.0
SC6A162	10	13.9	Max. 10	105.5	128.3	198.8	113.1	145.1	243.5	170.1	318.7	IE2	40.8
SC6A261	19	13.2	Max. 10	101.2	125.8	206.1	108.5	142.0	249.5	165.6	320.4	IE2	41.0

Tab. 21: Power loss data of the SC6 drive controller in accordance with EN 61800-9-2

General conditions

The specified losses apply to a drive controller. They apply to both axes together in the case of double-axis controllers.

The loss data applies to drive controllers without any accessories.

The power loss calculation is based on a three-phase supply voltage with 400 V_{AC}/50 Hz.

The calculated data includes a supplement of 10% in accordance with EN 61800-9-2.

The power loss specifications refer to a clock frequency of 4 kHz.

The absolute losses for a power unit that is switched off refer to the 24 V_{DC} power supply of the control electronics.

2.2.4.8 Power loss data of accessories

If you intend to order the drive controller with accessory parts, losses increase as follows.

Type	Absolute losses P_V [W]
SR6 safety module	1
SY6 or SU6 safety module	2

Tab. 22: Absolute losses of the accessories

Information

Note the absolute power loss of the encoder (usually < 3 W) and of the brake when designing as well.

Loss specifications for other optional accessories can be found in the technical data of the respective accessory part.

² Absolute losses for a power unit that is switched off

³ Operating points for relative motor stator frequency in % and relative torque current in %

⁴ IE class in accordance with EN 61800-9-2

⁵ Comparison of the losses for the reference related to IE2 in the nominal point (90, 100)

2.2.5 Cycle times

Possible cycle times can be found in the following table.

Type	Cycle times	Relevant parameters
Application	250 μ s, 500 μ s, 1 ms, 2 ms, 4 ms, 8 ms	Adjustable in A150
EtherCAT fieldbus, cyclical communication	250 μ s, 500 μ s, 1 ms, 2 ms, 4 ms, 8 ms	Adjustable in A150
PROFINET RT fieldbus, cyclical communication	1 ms, 2 ms, 4 ms, 8 ms	Adjustable in A150
PROFINET IRT fieldbus, cyclical communication	250 μ s, 500 μ s, 1 ms, 2 ms, 4 ms, 8 ms	Adjustable in A150
Digital inputs	250 μ s, 500 μ s, 1 ms, 2 ms, 4 ms, 8 ms	Adjustable in A150 ⁶
Motion core (movement calculation)	250 μ s	—
Control cascade	62.5 μ s, 125 μ s	Depending on B24

Tab. 23: Cycle times

2.2.6 Derating

When dimensioning the drive controller, observe the derating of the nominal output current as a function of the clock frequency, surrounding temperature and installation altitude. There is no restriction for a surrounding temperature from 0 °C to 45 °C and an installation altitude of 0 m to 1000 m. The details given below apply to values outside these ranges.

2.2.6.1 Effect of the clock frequency

Changing the clock frequency f_{PWM} affects the amount of noise produced by the drive, among other things. However, increasing the clock frequency results in increased losses. During project configuration, define the highest clock frequency and use it to determine the nominal output current $I_{2\text{N,PU}}$ for dimensioning the drive controller.

Type	$I_{2\text{N,PU}}$ 4 kHz [A]	$I_{2\text{N,PU}}$ 8 kHz [A]	$I_{2\text{N,PU}}$ 16 kHz [A]
SC6A062	2 × 4.5	2 × 4	2 × 3
SC6A162	2 × 10	2 × 9	2 × 5
SC6A261	19	15	8

Tab. 24: Nominal output current $I_{2\text{N,PU}}$ dependent on the clock frequency

2.2.6.2 Effect of the surrounding temperature

Derating as a function of the surrounding temperature is determined as follows:

- 0 °C to 45 °C: No restrictions ($D_T = 100\%$)
- 45 °C to 55 °C: Derating $-2.5\%/K$

Example

The drive controller needs to be operated at 50 °C.

The derating factor D_T is calculated as follows

$$D_T = 100\% - 5 \times 2.5\% = 87.5\%$$

2.2.6.3 Effect of the installation altitude

Derating as a function of the installation altitude is determined as follows:

- 0 m to 1000 m: No restriction ($D_{IA} = 100\%$)
- 1000 m to 2000 m: Derating $-1.5\%/100$ m

Example

The drive controller needs to be installed at an altitude of 1500 m above sea level.

The derating factor D_{IA} is calculated as follows:

$$D_{IA} = 100\% - 5 \times 1.5\% = 92.5\%$$

2.2.6.4 Calculating the derating

Follow these steps for the calculation:

1. Determine the highest clock frequency (f_{PWM}) that will be used during operation and use it to determine the nominal current $I_{2N,PU}$.
2. Determine the derating factors for installation altitude and surrounding temperature.
3. Calculate the reduced nominal current $I_{2N,PU(red)}$ in accordance with the following formula:

$$I_{2N,PU(red)} = I_{2N,PU} \times D_T \times D_{IA}$$

Example

A drive controller of type SC6A062 needs to be operated at a clock frequency of 8 kHz at an altitude of 1500 m above sea level and a surrounding temperature of 50 °C.

The nominal current of the SC6A062 at 8 kHz is 4 A per axis. The derating factor D_T is calculated as follows:

$$D_T = 100\% - 5 \times 2.5\% = 87.5\%$$

The derating factor D_{IA} is calculated as follows:

$$D_{IA} = 100\% - 5 \times 1.5\% = 92.5\%$$

The output current of importance for the project configuration is:

$$I_{2N,PU(red)} = 4 \text{ A} \times 0.875 \times 0.925 = 3.24 \text{ A}$$

2.2.7 Dimensions

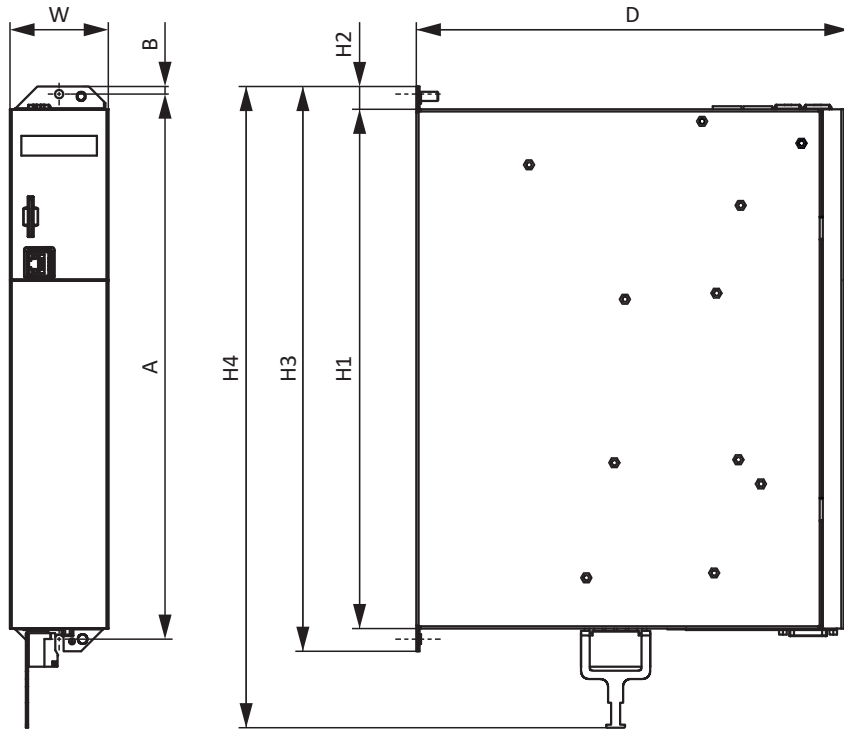

Fig. 2: SC6 dimensional drawing

Dimension		Size 0	Size 1	Size 2
Drive controller	Width	W	45	65
	Depth	D	265	286
	Body height	H1		343
	Fastening clip height	H2		15
	Height incl. fastening clips	H3		373
	Total height incl. shield connection	H4		423
Fastening holes (M5)	Vertical distance	A	360+2	
	Vertical distance to the upper edge	B	5	

Tab. 25: SC6 dimensions [mm]

2.2.8 Weight

Type	Weight without packaging [g]	Weight with packaging [g]
SC6A062	3600	5200
SC6A162	5300	6700
SC6A261	5200	6400

Tab. 26: SC6 weight [g]

2.2.9 Minimum clearances

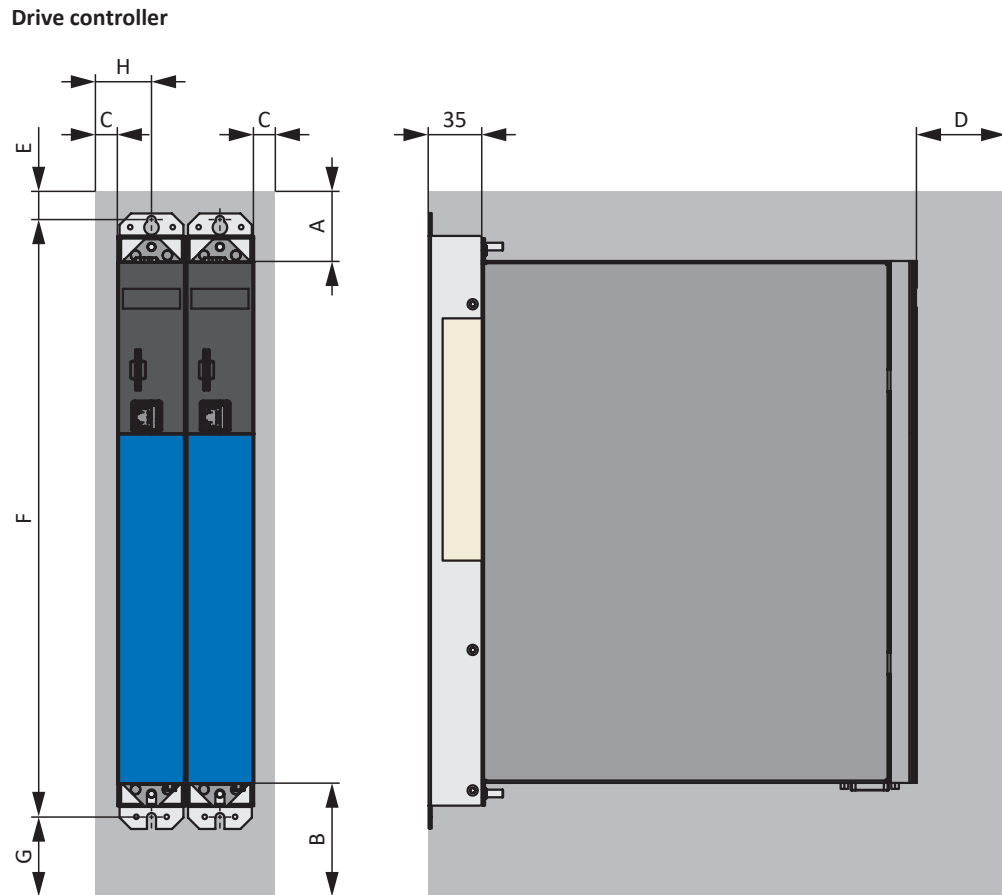

Fig. 3: Minimum clearances

The specified dimensions relate to the outer edges of the drive controller.

Minimum clearance	A (above)	B (below)	C (on the side)	D (in front)
All sizes	100	200	5	50 ⁷

Tab. 27: Minimum clearances [mm]

Dimension	E	F	G	H
SC6A062	73.5	393+2	approx. 174.5	27.5
SC6A162	73.5	393+2	approx. 174.5	37.5
SC6A261				

Tab. 28: Dimensions [mm]

Chokes and filters

Avoid installation below drive controllers or supply modules. For installation in a control cabinet, a distance of approximately 100 mm to other neighboring components is recommended. This distance ensures proper heat dissipation for chokes and filters.

Braking resistors

Avoid installation below drive controllers or supply modules. In order for heated air to flow out unimpeded, a minimum clearance of approximately 200 mm must be maintained in relation to neighboring components or walls and approximately 300 mm must be maintained to components above or ceilings.

⁷ Minimum clearance to be taken into account for permanent connection of the X9 service interface

2.3 Drive controller/motor combinations

An explanation of the symbols used for formulas can be found in Chapter [▶ 9.1](#).

EZ synchronous servo motor ($n_n = 3000$ rpm) – SC6

						SC6A062	SC6A162	SC6A261	SC6A062	SC6A162	SC6A261
						$I_{2N,PU}$ [A] ($f_{PWM,PU} = 4$ kHz)			$I_{2N,PU}$ [A] ($f_{PWM,PU} = 8$ kHz)		
	K_{EM} [V/1000 rpm]	M_N [Nm]	I_N [A]	M_0 [Nm]	I_0 [A]	4.5	10	19	4	9	15

IC 410 convection cooling						$I_{2N,PU} / I_0$					
EZ301U	40	0.93	1.99	0.95	2.02	2.2			2.0		
EZ302U	86	1.59	1.6	1.68	1.67	2.7			2.4		
EZ303U	109	2.07	1.63	2.19	1.71	2.6			2.3		
EZ401U	96	2.8	2.74	3	2.88	1.6			1.4		
EZ402U	94	4.7	4.4	5.2	4.8		2.1			1.9	
EZ404U	116	6.9	5.8	8.6	6.6		1.5			1.4	
EZ501U	97	4.3	3.74	4.7	4	1.1			1.0		
EZ502U	121	7.4	5.46	8	5.76		1.7			1.6	
EZ503U	119	9.7	6.9	11.1	7.67		1.3			1.2	2.0
EZ505U	141	13.5	8.8	16	10		1.0	1.9			1.5
EZ701U	95	7.4	7.2	8.3	8		1.3			1.1	1.9
EZ702U	133	12	8.2	14.4	9.6		1.0	2.0			1.6
EZ703U	122	16.5	11.4	20.8	14			1.4			1.1

IC 416 forced ventilation						$I_{2N,PU} / I_0$					
EZ401B	96	3.4	3.4	3.7	3.6	1.3			1.1		
EZ402B	94	5.9	5.5	6.3	5.8		1.7			1.6	
EZ404B	116	10.2	8.2	11.2	8.7		1.1	2.2		1.0	1.7
EZ501B	97	5.4	4.7	5.8	5		2.0			1.8	
EZ502B	121	10.3	7.8	11.2	8.16		1.2			1.1	1.8
EZ503B	119	14.4	10.9	15.9	11.8			1.6			1.3
EZ505B	141	20.2	13.7	23.4	14.7			1.3			1.0
EZ701B	95	9.7	9.5	10.5	10		1.0	1.9			1.5
EZ702B	133	16.6	11.8	19.3	12.9			1.5			1.2

EZ synchronous servo motor ($n_n = 4500$ rpm) – SC6

						SC6A062	SC6A162	SC6A261	SC6A062	SC6A162	SC6A261
						$I_{2N,PU}$ [A] ($f_{PWM,PU} = 4$ kHz)			$I_{2N,PU}$ [A] ($f_{PWM,PU} = 8$ kHz)		
	K_{EM} [V/1000 rpm]	M_N [Nm]	I_N [A]	M_0 [Nm]	I_0 [A]	4.5	10	19	4	9	15

IC 410 convection cooling						$I_{2N,PU} / I_0$					
EZ505U	103	9.5	8.9	15.3	13.4			1.4			1.1
EZ703U	99	12.1	11.5	20	17.8			1.1			

EZ synchronous servo motor ($n_n = 6000$ rpm) – SC6

						SC6A062	SC6A162	SC6A261	SC6A062	SC6A162	SC6A261
						$I_{2N,PU}$ [A] ($f_{PWM,PU} = 4$ kHz)			$I_{2N,PU}$ [A] ($f_{PWM,PU} = 8$ kHz)		
	K_{EM} [V/1000 rpm]	M_N [Nm]	I_N [A]	M_0 [Nm]	I_0 [A]	4.5	10	19	4	9	15
IC 410 convection cooling						$I_{2N,PU} / I_0$					
EZ202U	40	0.44	1.07	0.48	1.12	4.0			3.6		
EZ203U	40	0.64	1.53	0.73	1.65	2.7			2.4		
EZ301U	40	0.89	1.93	0.95	2.02	2.2			2.0		
EZ302U	42	1.5	3.18	1.68	3.48	1.3			1.1		
EZ303U	55	1.96	3.17	2.25	3.55	1.3			1.1		
EZ401U	47	2.3	4.56	2.8	5.36		1.9			1.7	
EZ402U	60	3.5	5.65	4.9	7.43		1.3			1.2	2.0
EZ404U	78	5.8	7.18	8.4	9.78		1.0	1.9			1.5
EZ501U	68	3.4	4.77	4.4	5.8		1.7			1.6	
EZ502U	72	5.2	7.35	7.8	9.8		1.0	1.9			1.5
EZ503U	84	6.2	7.64	10.6	11.6			1.6			1.3
EZ701U	76	5.2	6.68	7.9	9.38		1.1	2.0			1.6
EZ702U	82	7.2	8.96	14.3	16.5			1.2			
IC 416 forced ventilation						$I_{2N,PU} / I_0$					
EZ401B	47	2.9	5.62	3.5	6.83		1.5			1.3	2.2
EZ402B	60	5.1	7.88	6.4	9.34		1.1	2.0			1.6
EZ404B	78	8	9.98	10.5	12			1.6			1.3
EZ501B	68	4.5	6.7	5.7	7.5		1.3			1.2	2.0
EZ502B	72	8.2	11.4	10.5	13.4			1.4			1.1
EZ503B	84	10.4	13.5	14.8	15.9			1.2			
EZ701B	76	7.5	10.6	10.2	12.4			1.5			1.2

2.4 Accessories

You can find information about the available accessories in the following chapters.

2.4.1 Safety technology

Information

The drive controller is delivered in the standard design without safety technology (option SZ6). If you want a drive controller with integrated safety technology, you must order it together with the drive controller. The safety modules are an integrated part of the drive controllers and must not be modified.

SZ6 option – Without safety technology

Included in the standard version.

ID No. 56660

Design without safety technology.

SR6 safety module – STO using terminals

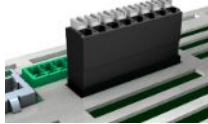

ID No. 56661

Optional accessory for the use of the Safe Torque Off safety function (STO) in safety-relevant applications (PL e, SIL 3) in accordance with EN ISO 13849-1 and EN 61800-5-2. Connection to a higher-level safety circuit via terminal X12.

SY6 safety module – STO and SS1 using FSoE



ID No. 56662

Optional accessory for the use of the Safe Torque Off (STO) and Safe Stop 1 (SS1) safety functions in safety-relevant applications (PL e, SIL 3) in accordance with EN ISO 13849-1 and EN 61800-5-2. Connection to the higher-level safety circuit using Fail Safe over EtherCAT (FSoE).

SU6 safety module – STO and SS1 using PROFIsafe



ID No. 56696

Optional accessory for the use of the Safe Torque Off (STO) and Safe Stop 1 (SS1) safety functions in safety-relevant applications (PL e, SIL 3) in accordance with EN ISO 13849-1 and EN 61800-5-2. Connection to a higher-level safety circuit via PROFINET (PROFIsafe).

2.4.2 Communication

The drive controller has two interfaces for the fieldbus connection on the top of the device as well as an Ethernet service interface on the front of the device. Cables for the connection are available separately.

EtherCAT or PROFINET fieldbus system

EtherCAT®

PROFI®
NET

Please specify the desired fieldbus system when placing your order for the base device, since the fieldbus communication is defined using the firmware.

EtherCAT cables



Ethernet patch cable, CAT5e, yellow.

The following designs are available:

ID No. 49313: Length approx. 0.25 m.

ID No. 49314: Length approx. 0.5 m.

PC connecting cables



ID No. 49857

Cable for connecting the X9 service interface to the PC, CAT5e, blue, 5 m.

USB 2.0 Ethernet adapter



ID No. 49940

Adapter for connecting Ethernet to a USB port.

2.4.3 Terminal set

For connection, you need the fitting terminal set for each SC6 drive controller.

Terminal set for drive controllers – SZ6 option (without safety technology), SU6 option (STO and SS1 using PROFIsafe) or SY6 option (STO and SS1 using FSoE)

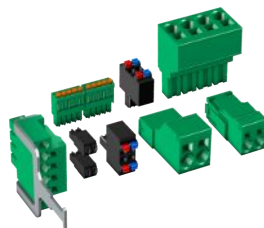

(Fig. similar)

The following designs are available:

ID No. 138652

Terminal set for SC6A062Z/U/Y.

ID No. 138653

Terminal set for SC6A162Z/U/Y.

ID No. 138654

Terminal set for SC6A261Z/U/Y.

Terminal set for drive controllers – SR6 option (STO via terminals)

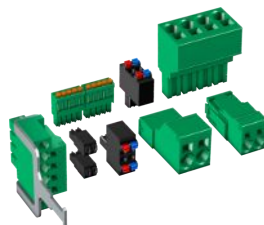

(Fig. similar)

The following designs are available:

ID No. 138680

Terminal set for SC6A062R.

ID No. 138681

Terminal set for SC6A162R.

ID No. 138682

Terminal set for SC6A261R.

2.4.4 DC link connection

If you want to connect SC6 drive controllers in the DC link group, you will need Quick DC-Link modules of type DL6B.

You receive the DL6B rear section modules in different designs for a horizontal connection, suitable for the size of the drive controller.

The quick fastening clamps for attaching the copper rails and an insulation connection piece are contained in the scope of delivery. The copper rails are not included in the scope of delivery. These must have a cross-section of 5 x 12 mm. Insulation end sections are available separately.

Quick DC-Link DL6B for drive controller



The following designs are available:

DL6B10

ID No. 56655

Rear section module for size 0 drive controller:

SC6A062

DL6B11

ID No. 56656

Rear section module for size 1 or 2 drive controller:

SC6A162 and SC6A261

Quick DC-Link DL6B insulation end section

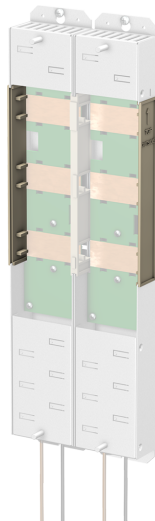

ID No. 56659

Insulation end sections for the left and right termination of the group, 2 pcs.

2.4.5 Braking resistor

In addition to drive controllers, STOBBER offers the following braking resistors described below in various sizes and performance classes. For the selection, note the minimum permitted braking resistors specified in the technical data of the individual drive controller types.

2.4.5.1 Tubular fixed resistor FZMU, FZZMU

Type	FZMU 400×65	FZZMU 400×65
ID No.	49010	53895
SC6A062	X	—
SC6A162	(X)	X
SC6A261	(X)	X

Tab. 29: Assignment of FZMU, FZZMU braking resistor – SC6 drive controller

X	Recommended
(X)	Possible
—	Not possible

Properties

Specification	FZMU 400×65	FZZMU 400×65
ID No.	49010	53895
Type	Tubular fixed resistor	Tubular fixed resistor
Resistance [Ω]	100 \pm 10%	47 \pm 10%
Thermal drift	\pm 10%	\pm 10%
Power [W]	600	1200
Therm. time const. τ_{th} [s]	40	40
Pulse power for < 1 s [kW]	18	36
U_{max} [V]	848	848
Weight without packaging [g]	2200	4170
Protection class	IP20	IP20
Test symbols	cURus, CE, UKCA	cURus, CE, UKCA

Tab. 30: FZMU, FZZMU specification

Dimensions

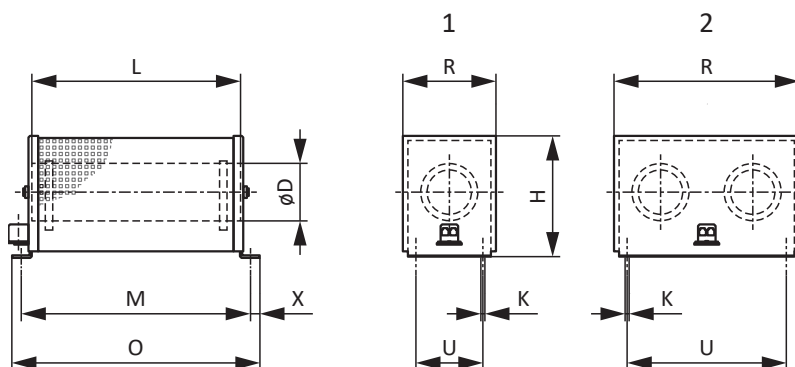

Fig. 4: FZMU (1), FZZMU (2) dimensional drawing

Dimension	FZMU 400×65	FZZMU 400×65
ID No.	49010	53895
L x D	400 × 65	400 × 65
H	120	120
K	6.5 × 12	6.5 × 12
M	430	426
O	485	485
R	92	185
U	64	150
X	10	10

Tab. 31: FZMU, FZZMU dimensions [mm]

2.4.5.2 GVADU, GBADU flat resistor

Type	GVADU 210×20	GBADU 265×30	GBADU 335×30
ID No.	55441	55442	55443
SC6A062	X	X	—
SC6A162	(X)	(X)	X
SC6A261	(X)	(X)	X

Tab. 32: Assignment of GVADU, GBADU braking resistor – SC6 drive controller

X	Recommended
(X)	Possible
—	Not possible

Properties

Specification	GVADU 210×20	GBADU 265×30	GBADU 335×30
ID No.	55441	55442	55443
Type	Flat resistor		
Resistance [Ω]	100 \pm 10%	100 \pm 10%	47 \pm 10%
Thermal drift	\pm 10%	\pm 10%	\pm 10%
Power [W]	150	300	400
Therm. time const. τ_{th} [s]	60	60	60
Pulse power for < 1 s [kW]	3.3	6.6	8.8
U_{max} [V]	848	848	848
Cable design	Radox	FEP	FEP
Cable length [mm]	500	1500	1500
Conductor cross-section [AWG]	18/19 (0.82 mm ²)	14/19 (1.9 mm ²)	14/19 (1.9 mm ²)
Weight without packaging [g]	300	930	1200
Protection class	IP54	IP54	IP54
Test symbols	cURus, CE, UKCA		

Tab. 33: GVADU, GBADU specification

Dimensions

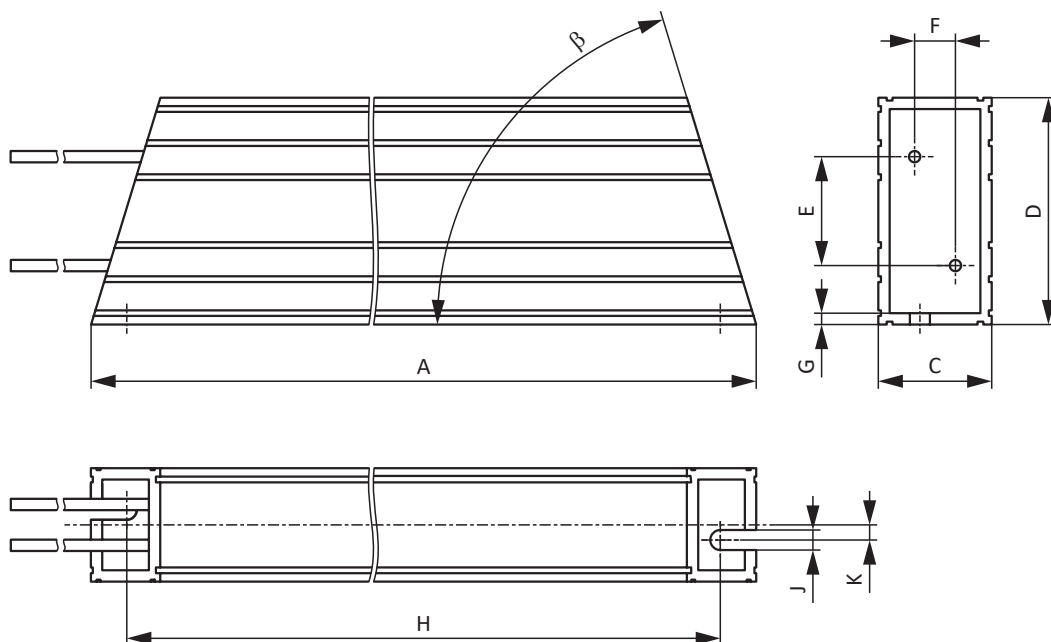

Fig. 5: GVADU, GBADU dimensional drawing

Dimension	GVADU 210×20	GBADU 265×30	GBADU 335×30
ID No.	55441	55442	55443
A	210	265	335
H	192	246	316
C	20	30	30
D	40	60	60
E	18.2	28.8	28.8
F	6.2	10.8	10.8
G	2	3	3
K	2.5	4	4
J	4.3	5.3	5.3
β	65°	73°	73°

Tab. 34: GVADU, GBADU dimensions [mm]

2.4.6 Choke

Technical specifications for suitable chokes can be found in the following chapters.

2.4.6.1 TEP output choke

Output chokes are required for connecting size 0 to 2 drive controllers to synchronous servo motors or asynchronous motors from a cable length > 50 m in order to reduce interference pulses and protect the drive system. If Lean motors are connected, output chokes must not be used.

Information

The following technical data only applies to a rotating magnetic field frequency of 200 Hz. For example, this rotating magnetic field frequency is achieved with a motor with 4 pole pairs and a nominal speed of 3000 rpm. Always observe the specified derating for higher rotating magnetic field frequencies. Also observe the relationship with the clock frequency.

Properties

Specification	TEP3720-0ES41	TEP3820-0CS41	TEP4020-0RS41
ID No.	53188	53189	53190
Voltage range	3 × 0 to 480 V _{AC}		
Frequency range	0 – 200 Hz		
Nominal current I _{N,MF} at 4 kHz	4 A	17.5 A	38 A
Nominal current I _{N,MF} at 8 kHz	3.3 A	15.2 A	30.4 A
Max. permitted motor cable length with output choke	100 m		
Max. surrounding temperature $\vartheta_{amb,max}$	40 °C		
Protection class	IP00		
Winding losses	11 W	29 W	61 W
Iron losses	25 W	16 W	33 W
Connection	Screw terminal		
Max. conductor cross-section	10 mm ²		
UL Recognized Component (CAN; USA)	Yes		
Test symbols	cURus, CE		

Tab. 35: TEP specification

Dimensions

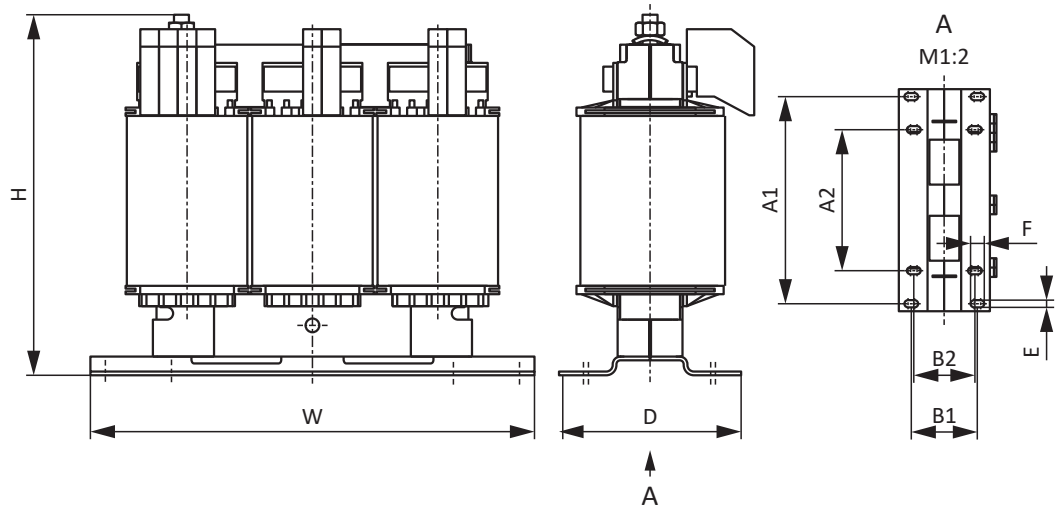

Fig. 6: TEP dimensional drawing

Dimension	TEP3720-0ES41	TEP3820-0CS41	TEP4020-0RS41
Height H [mm]	Max. 153	Max. 153	Max. 180
Width W [mm]	178	178	219
Depth D [mm]	73	88	119
Vertical distance – Fastening holes A1 [mm]	166	166	201
Vertical distance – Fastening holes A2 [mm]	113	113	136
Horizontal distance – Fastening holes B1 [mm]	53	68	89
Horizontal distance – Fastening holes B2 [mm]	49	64	76
Drill holes – Depth E [mm]	5.8	5.8	7
Drill holes – Width F [mm]	11	11	13
Screw connection – M	M5	M5	M6
Weight without packaging [g]	2900	5900	8800

Tab. 36: TEP dimensions and weight

2.4.7 Encoder battery module

Absolute Encoder Support AES



ID No. 55452

Battery module for buffering the supply voltage when using the EnDat 2.2 digital inductive encoder with battery-buffered multi-turn stage, for example EBI1135 or EBI135.

A battery is included.

Information

Note that a 15-pin extension cable between the socket and the AES may be necessary for the connection to the drive controller due to limited space.

- A commercially available shielded extension cable with a 15-pin D-sub connector and a length of ≤ 1 m can be used between the socket and the AES.

AES replacement battery



ID No. 55453

Replacement battery for AES battery module.

2.4.8 HTL-to-TTL adapter

HT6 HTL-to-TTL adapter



ID No. 56665

Adapters for SC6 and SI6 series drive controllers for level conversion from HTL signals to TTL signals.

It is used to connect an HTL differential incremental encoder to terminal X4 of the drive controller.

2.5 Further information

2.5.1 Directives and standards

The following European directives and standards are relevant to the drive controllers:

- Machinery Directive 2006/42/EC
- Low Voltage Directive 2014/35/EU
- EMC Directive 2014/30/EU
- EN ISO 13849-1:2015
- EN ISO 13849-2:2012
- EN 61800-3:2018
- EN 61800-5-1:2017
- EN 61800-5-2:2017

2.5.2 Symbols, marks and test symbols



Grounding symbol

Grounding symbol in accordance with IEC 60417, symbol 5019.



RoHS lead-free mark

Marking in accordance with RoHS directive 2011-65-EU.



CE mark

Manufacturer's self declaration: The product meets the requirements of EU directives.



UKCA test symbol

Manufacturer's self declaration: The product meets the requirements of UK directives.



UL test symbol

This product is listed by UL for the United States and Canada. Representative samples of this product have been evaluated by UL and meet the requirements of applicable standards.



UL recognized component mark

This component or material is recognized by UL. Representative samples of this product have been evaluated by UL and meet applicable requirements.

2.5.3 Additional documentation

Additional documentation related to the product can be found at <http://www.stoeber.de/en/downloads/>

Enter the ID of the documentation in the Search field.

Documentation	ID
Manual for SC6 drive controllers	442790

3 SI6 Drive controllers

Table of contents

3.1	Overview	50
3.1.1	Features.....	51
3.1.2	Software components	52
3.1.3	Application training.....	53
3.2	Technical data	54
3.2.1	General technical data	54
3.2.2	Drive controllers.....	55
3.2.3	Supply module.....	63
3.2.4	DC link connection.....	68
3.2.5	Minimum clearances.....	72
3.3	Drive controller/motor combinations.....	74
3.4	Accessories	76
3.4.1	Safety technology.....	76
3.4.2	Communication.....	77
3.4.3	Terminal set.....	78
3.4.4	DC link connection.....	79
3.4.5	Braking resistor	80
3.4.6	Choke	85
3.4.7	Encoder battery module	89
3.4.8	HTL-to-TTL adapter.....	89
3.5	Further information	90
3.5.1	Directives and standards.....	90
3.5.2	Symbols, marks and test symbols	90
3.5.3	Additional documentation	90



3 Drive controllers

SI6

3.1 Overview

Drive control in a multi-axis drive system

Features

- Single or double-axis controller with a nominal output current up to 50 A and 250% overload capacity
- Supply modules up to 50 kW nominal power
- Sensorless position control of STOBER Lean motors
- Control of rotary synchronous servo motors, asynchronous motors and torque motors
- One Cable Solution EnDat 3
- Electronic motor nameplate via EnDat encoder interfaces
- Integrated EtherCAT or PROFINET communication
- STO safety technology using terminals or STO and SS1 using FSoE or PROFIsafe: SIL 3, PL e (Cat. 4)
- Integrated brake control
- Energy supply over DC link connection
- Single-ended nominal power consumption on double-axis controllers for operation of motors with different power
- Variable feed-in power using supply modules that can be connected in parallel

3.1.1 Features

The completely re-designed STOBBER multi-axis drive system consists of the SI6 drive controller and PS6 supply module combination. Matching Quick DC-Link modules handle the energy supply for the networked drive controllers. The SI6 drive controller is available in four sizes as a single or double-axis controller with a nominal output current of up to 50. The PS6 supply module is available in three sizes with a nominal power of 10 kW to 50 kW. As an economically attractive system with a minimized device width, the SI6 opens a new dimension in multi-axis applications.

For STOBBER synchronous servo motors, we recommended operation with the EnDat 2.2 digital encoder or as a One Cable Solution with EnDat 3. These encoder systems make it possible to attain the highest control quality. It is possible to perform motor parameterization automatically from the electronic motor name-plate.



Drive control in multi-axis drive systems with SI6 and PS6

As small as a paperback

You save valuable space in your control cabinet because, with a width of just 45 mm, this drive controller is the most compact solution on the market. It offers all the features that a designer requires.

Dimension capacities precisely

4 axes? 16? Or even 97? A single SI6 drive controller can control up to two axes. Thanks to the multi-axis drive system, the number of motors or axes to be controlled can be scaled without limit. If required, SI6 drive controllers can be combined with stand-alone units from the STOBBER SC6 or SD6 series. For the general energy supply, the drive controllers from the SI6, SC6 and SD6 series can be connected to each other using Quick DC-Link modules.

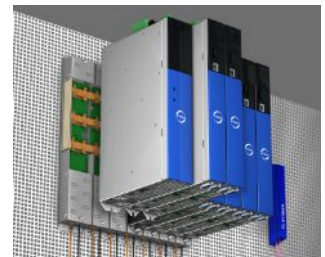

Tailored energy usage

The SI6 drive controllers are connected to a central supply module. There is no need for decentralized supply modules or fuses and cabling for each axis. When using double-axis modules, the unused power reserves of one axis can be used for the second axis. A significant reduction in space and cost!

Precise dynamics

The drive controller provides acceleration that is literally as fast as lightning. For example, in conjunction with the STOBBER EZ401 synchronous servo motor: from 0 to 3000 rpm in 10 ms.

Fewer clicks, less wiring

Installation is exceptionally simple. No difficult wiring. The patented Quick DC-Link modules allow for a simple "click" into the standard copper rails, as well as the simple installation and connection of the drive controllers. The encoder communication and power connection of the motor takes place using a common cable connection. The EnDat 3 encoder system provides an electronic motor nameplate that takes care of the parameterization of motor data simply and safely. EnDat 2.2 digital offers an alternative interface, which also has an electronic nameplate function.

**Safety functions**

The safety concept of the drive controller is based on the STO (Safe Torque Off) function. The concept corresponds to SIL 3 according to DIN EN 61800-5-2 and PL e (Cat. 4) according to DIN EN ISO 13849-1. For double-axis controllers, the STO safety function has a two-channel structure that acts upon both axes. For connection to a higher-level safety circuit, different interfaces are available (terminals, FSoE or PROFIsafe).

Heavy duty

There is an extremely robust design concealed behind the elegant exterior. All components—from the stable, well-shielded sheet steel housing to the motor connectors—far exceed the set values of industry standards. The inside is also anything but small-scale: ample computer capacities, high-quality components, careful workmanship.

3.1.2 Software components

Project configuration and commissioning

The 6th generation of DriveControlSuite project configuration and commissioning software has all the functions for the efficient use of drive controllers in single-axis and multi-axis applications. The program guides you step by step through the complete project configuration and parameterization process using wizards.

Open communication

The Ethernet-based EtherCAT and PROFINET fieldbus systems are available in the drive controller.

Applications

A controller-based application is recommended for the central motion control of complex machines.

With the controller-based operating modes of the CiA 402 application (csp, csv, cst, ip) or the controller-based application class of the PROFIdrive application (AC4), you can implement applications with synchronized, cyclic set value specification by a motion controller. In addition, the drive controllers can also independently handle motion tasks, such as referencing and jogging during commissioning.

Drive-based Drive Based and Drive Based Synchronous applications, drive-based operating modes of the CiA 402 application (pp, pv, pt) and drive-based application classes of the PROFIdrive application (AC1, AC3) are also available.

3.1.3 Application training

STOBER offers a multi-level training program that is essentially focused on the drive controller.

G6 Basic

Training content: System overview, installation and commissioning of the drive controller. Use of option modules. Parameterization, commissioning and diagnostics using the commissioning software. Remote maintenance. Basics of controller optimization. Configuration of the drive train. Integrated software functions. Software applications. Connection to a higher-level controller. Basics of safety technology. Practical exercises on training topics.

Software used: DriveControlSuite.

G6 Customized

Training content: Special knowledge for regulating, control and safety technology. Electronic cam disk. Practical exercises on training topics.

3.2 Technical data

Technical data for the drive controllers, supply modules and accessories can be found in the following chapters.

3.2.1 General technical data

The following specifications apply equally to the SI6 drive controller and the PS6 supply module.

Device features	
Protection class of the device	IP20
Protection class of the installation space	At least IP54
Protection class	Protection class I in accordance with EN 61140
Radio interference suppression	Integrated line filter in accordance with EN 61800-3, interference emission class C3
Overvoltage category	III in accordance with EN 61800-5-1
Test symbols	CE, cULus, RoHS

Tab. 1: Device features

Transport and storage conditions	
Storage/ transport temperature	-20 °C to +70 °C Maximum change: 20 K/h
Relative humidity	Maximum relative humidity 85%, non-condensing
Vibration (transport) in accordance with EN 60068-2-6	5 Hz ≤ f ≤ 9 Hz: 3.5 mm 9 Hz ≤ f ≤ 200 Hz: 10 m/s ² 200 Hz ≤ f ≤ 500 Hz: 15 m/s ²
Fall height for freefall ¹ Weight < 100 kg in accordance with EN 61800-2 (or IEC 60721-3-2, class 2M1)	0.25 m

Tab. 2: Transport and storage conditions

Operating conditions	
Surrounding temperature during operation	0 °C to 45 °C with nominal data 45 °C to 55 °C with derating -2.5% / K
Relative humidity	Maximum relative humidity 85%, non-condensing
Installation altitude	0 m to 1000 m above sea level without restrictions 1000 m to 2000 m above sea level with -1.5%/100 m derating
Pollution degree	Pollution degree 2 in accordance with EN 50178
Ventilation	Installed fan
Vibration (operation) in accordance with EN 60068-2-6	5 Hz ≤ f ≤ 9 Hz: 0.35 mm 9 Hz ≤ f ≤ 200 Hz: 1 m/s ²

Tab. 3: Operating conditions

Discharge times	
Self-discharge of DC link	15 min
Fast discharge of DC link	Thanks to PS6 supply module in combination with a braking resistor: < 1 min

Tab. 4: Discharge times of the DC link circuit

3.2.2 Drive controllers

The following chapters contain specifications for the electrical data, dimensions and weight of the drive controller.

3.2.2.1 Type designation

SI	6	A	0	6	1	Z
----	---	---	---	---	---	---

Tab. 5: Example code for drive controller type designation

Code	Designation	Design
SI	Series	
6	Generation	Generation 6
A	Version	
0 – 3	Size	
6	Power output stage	Power output stage within the size
1	Axis controller	Single-axis controller
2		Double-axis controller
Z	Safety technology	SZ6: Without safety technology
R		SR6: STO using terminals
U		SU6: STO and SS1 using PROFIsafe
Y		SY6: STO and SS1 using FSoE

Tab. 6: Meaning of the example code

3.2.2.2 Sizes

Type	ID No.	Size	Axis controller
SI6A061	56645	Size 0	Single-axis controller
SI6A062	56646	Size 0	Double-axis controller
SI6A161	56647	Size 1	Single-axis controller
SI6A162	56648	Size 1	Double-axis controller
SI6A261	56649	Size 2	Single-axis controller
SI6A262	56653	Size 2	Double-axis controller
SI6A361	56654	Size 3	Single-axis controller

Tab. 7: Available SI6 types and sizes



SI6 in sizes 0 to 3

Note that the basic device is delivered without terminals. Suitable terminal sets are available separately for each size.

3.2.2.3 Electrical data

The electrical data of the available SI6 sizes can be found in the following sections.

An explanation of the symbols used for formulas can be found in Chapter [\[9.1 \]](#).

3.2.2.3.1 Control unit

Electrical data	All types
U_{1CU}	24 V _{DC} +20%/–15%
I_{1maxCU}	0.5 A

Tab. 8: Control unit electrical data

3.2.2.3.2 Power unit: Size 0

Electrical data	SI6A061	SI6A062
U_{1PU}	280 – 800 V _{DC}	
f_{2PU}	0 – 700 Hz	
U_{2PU}	0 – max. $\frac{U_{1PU}}{\sqrt{2}}$	
C_{PU}	180 μF	270 μF

Tab. 9: SI6 electrical data, size 0

Nominal currents up to +45 °C (in the control cabinet)

Electrical data	SI6A061	SI6A062
$f_{PWM,PU}$	4 kHz	
$I_{2N,PU}$	5 A	2 × 5 A
I_{2maxPU}	210% for 2 s; 150% for 30 s	

Tab. 10: SI6 electrical data, size 0, for 4 kHz clock frequency

Electrical data	SI6A061	SI6A062
$f_{PWM,PU}$	8 kHz	
$I_{2N,PU}$	4.5 A	2 × 4.5 A
I_{2maxPU}	250% for 2 s; 200% for 5 s	

Tab. 11: SI6 electrical data, size 0, for 8 kHz clock frequency

3.2.2.3.3 Power unit: Size 1

Electrical data	SI6A161	SI6A162
U_{1PU}	280 – 800 V _{DC}	
f_{2PU}	0 – 700 Hz	
U_{2PU}	0 – max. $\frac{U_{1PU}}{\sqrt{2}}$	
C_{PU}	470 μF	940 μF

Tab. 12: SI6 electrical data, size 1

Nominal currents up to +45 °C (in the control cabinet)

Electrical data	SI6A161	SI6A162
$f_{PWM,PU}$	4 kHz	
$I_{2N,PU}$	12 A	2 × 12 A
I_{2maxPU}	210% for 2 s; 150% for 30 s	

Tab. 13: SI6 electrical data, size 1, for 4 kHz clock frequency

Electrical data	SI6A161	SI6A162
$f_{PWM,PU}$	8 kHz	
$I_{2N,PU}$	10 A	2 × 10 A
I_{2maxPU}	250% for 2 s; 200% for 5 s	

Tab. 14: SI6 electrical data, size 1, for 8 kHz clock frequency

3.2.2.3.4 Power unit: Size 2

Electrical data	SI6A261	SI6A262
U_{1PU}	280 – 800 V _{DC}	
f_{2PU}	0 – 700 Hz	
U_{2PU}	0 – max. $\frac{U_{1PU}}{\sqrt{2}}$	
C_{PU}	940 μ F	2250 μ F

Tab. 15: SI6 electrical data, size 2

Nominal currents up to +45 °C (in the control cabinet)

Electrical data	SI6A261	SI6A262
$f_{PWM,PU}$	4 kHz	
$I_{2N,PU}$	22 A	2 × 25 A
I_{2maxPU}	210% for 2 s; 150% for 30 s	

Tab. 16: SI6 electrical data, size 2, for 4 kHz clock frequency

Electrical data	SI6A261	SI6A262
$f_{PWM,PU}$	8 kHz	
$I_{2N,PU}$	20 A	2 × 20 A
I_{2maxPU}	250% for 2 s; 200% for 5 s	

Tab. 17: SI6 electrical data, size 2, for 8 kHz clock frequency

3.2.2.3.5 Power unit: Size 3

Electrical data	SI6A361
U_{1PU}	280 – 800 V _{DC}
f_{2PU}	0 – 700 Hz
U_{2PU}	0 – max. $\frac{U_{1PU}}{\sqrt{2}}$
C_{PU}	2250 μ F

Tab. 18: SI6 electrical data, size 3

Nominal currents up to +45 °C (in the control cabinet)

Electrical data	SI6A361
$f_{PWM,PU}$	4 kHz
$I_{2N,PU}$	50 A
I_{2maxPU}	210% for 2 s; 150% for 30 s

Tab. 19: SI6 electrical data, size 3, for 4 kHz clock frequency

Electrical data	SI6A361
$f_{PWM,PU}$	8 kHz
$I_{2N,PU}$	40 A
I_{2maxPU}	250% for 2 s; 200% for 5 s

Tab. 20: SI6 electrical data, size 3, for 8 kHz clock frequency

3.2.2.3.6 Single-ended nominal power consumption on double-axis controllers

Operating two motors on one double-axis controller makes it possible to operate one of the motors with a continuous current above the nominal current of the drive controller if the continuous current of the second connected motor is lower than the nominal current of the drive controller. This enables economical combinations of double-axis controllers and motors.

The nominal output current for axis B can be determined using the following formula if the output current for axis A is known:

Example 1

$$I_{2PU(B)} = I_{2N,PU} - (I_{2PU(A)} - I_{2N,PU}) \times \frac{3}{5} \quad \text{where} \quad 0 \leq I_{2PU(A)} \leq I_{2N,PU}$$

Example 2

$$I_{2PU(B)} = I_{2N,PU} - (I_{2PU(A)} - I_{2N,PU}) \times \frac{5}{3} \quad \text{where} \quad I_{2N,PU} \leq I_{2PU(A)} \leq 1,6 \times I_{2N,PU}$$

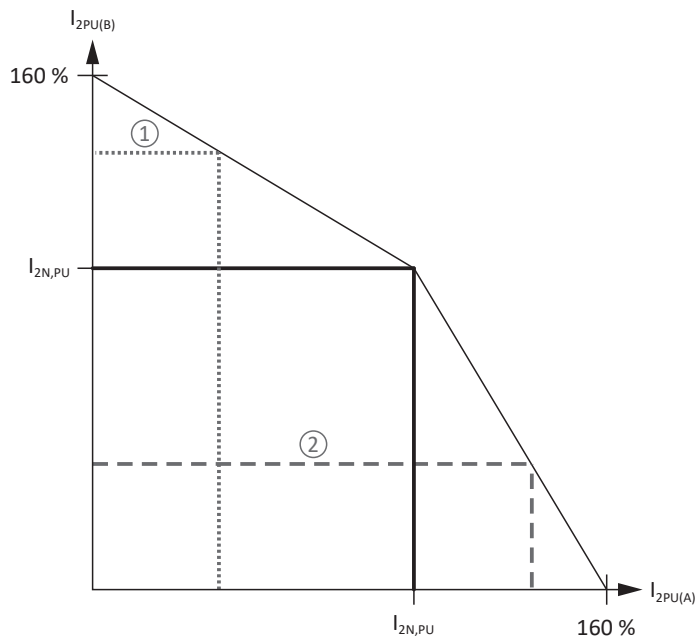

Fig. 1: Asymmetric load on double-axis controllers

Information

Note that the available maximum currents I_{2maxPU} of the axis controllers are also relative to the nominal output current $I_{2N,PU}$ for single-ended nominal power consumption.

3.2.2.3.7 Power loss data in accordance with EN 61800-9-2

Type	Nominal current $I_{2N,PU}$	Apparent power	Absolute losses $P_{V,CU}^2$	Operating points ³								IE class ⁴	Comparison ⁵	
				(0/25)	(0/50)	(0/100)	(50/25)	(50/50)	(50/100)	(90/50)	(90/100)			
				Relative losses										
				[A]	[kVA]	[W]	[%]							
SI6A06x	5	3.5	Max. 10	0.71	0.86	1.33	0.76	0.97	1.61	1.13	2.13	IE2		
SI6A16x	12	8.3	Max. 10	0.55	0.71	1.19	0.59	0.80	1.44	0.94	1.87	IE2		
SI6A261	22	16.6	Max. 10	0.55	0.71	1.19	0.59	0.80	1.44	0.94	1.87	IE2		
SI6A262	25	17.3	Max. 10	0.45	0.62	1.12	0.50	0.74	1.47	0.95	2.12	IE2		
SI6A361	50	34.6	Max. 10	0.45	0.62	1.12	0.50	0.74	1.47	0.95	2.12	IE2		
				Absolute losses P_V										
				[A]	[kVA]	[W]	[W]						[%]	
SI6A06x	5	3.5	Max. 10	25	30.2	46.5	26.5	33.8	56.5	39.5	74.4	IE2	24.9	
SI6A16x	12	8.3	Max. 10	45.7	58.7	98.7	49.1	66.3	119.6	78.1	155.4	IE2	26.7	
SI6A261	22	16.6	Max. 10	91.5	117.4	197.3	98.2	132.6	239.2	156.2	310.8	IE2	30.8	
SI6A262	25	17.3	Max. 10	77.9	106.5	193.0	87.1	127.9	254.3	163.8	367.6	IE2	36.4	
SI6A361	50	34.6	Max. 10	155.8	213.1	386.0	174.3	255.8	508.6	327.6	735.2	IE2	39.5	

Tab. 21: Power loss data in accordance with EN 61800-9-2 for one axis of a SI6 drive controller

General conditions

The specified losses apply to an axis of a drive controller and take into account the proportionate losses of the PS6 supply module for that axis.

For a group with a total of x axes, the values are to be multiplied by the number of axis controllers (x), e.g. x = 4 for 1 × PS6 and 2 × SI6A062.

The loss data applies to drive controllers without any accessories.

The power loss calculation is based on a three-phase supply voltage with 400 V_{AC}/50 Hz.

The calculated data includes a supplement of 10% in accordance with EN 61800-9-2.

The power loss specifications refer to a clock frequency of 4 kHz.

The absolute losses for a power unit that is switched off refer to the 24 V_{DC} power supply of the control electronics.

3.2.2.3.8 Power loss data of accessories

If you intend to order the drive controller with accessory parts, losses increase as follows.

Type	Absolute losses P_V [W]
SR6 safety module	1
SY6 or SU6 safety module	2

Tab. 22: Absolute losses of the accessories

Information

Note the absolute power loss of the encoder (usually < 3 W) and of the brake when designing as well.

Loss specifications for other optional accessories can be found in the technical data of the respective accessory part.

² Absolute losses for a power unit that is switched off

³ Operating points for relative motor stator frequency in % and relative torque current in %

⁴ IE class in accordance with EN 61800-9-2

⁵ Comparison of the losses for the reference related to IE2 in the nominal point (90, 100)

3.2.2.4 Cycle times

Possible cycle times can be found in the following table.

Type	Cycle times	Relevant parameters
Application	250 μ s, 500 μ s, 1 ms, 2 ms, 4 ms, 8 ms	Adjustable in A150
EtherCAT fieldbus, cyclical communication	250 μ s, 500 μ s, 1 ms, 2 ms, 4 ms, 8 ms	Adjustable in A150
PROFINET RT fieldbus, cyclical communication	1 ms, 2 ms, 4 ms, 8 ms	Adjustable in A150
PROFINET IRT fieldbus, cyclical communication	250 μ s, 500 μ s, 1 ms, 2 ms, 4 ms, 8 ms	Adjustable in A150
Digital inputs	250 μ s, 500 μ s, 1 ms, 2 ms, 4 ms, 8 ms	Adjustable in A150 ⁶
Motion core (movement calculation)	250 μ s	—
Control cascade	62.5 μ s, 125 μ s	Depending on B24

Tab. 23: Cycle times

3.2.2.5 Derating

When dimensioning the drive controller, observe the derating of the nominal output current as a function of the clock frequency, surrounding temperature and installation altitude. There is no restriction for a surrounding temperature from 0 °C to 45 °C and an installation altitude of 0 m to 1000 m. The details given below apply to values outside these ranges.

3.2.2.5.1 Effect of the clock frequency

Changing the clock frequency f_{PWM} affects the amount of noise produced by the drive, among other things. However, increasing the clock frequency results in increased losses. During project configuration, define the highest clock frequency and use it to determine the nominal output current $I_{2\text{N,PU}}$ for dimensioning the drive controller.

Type	$I_{2\text{N,PU}}$ 4 kHz [A]	$I_{2\text{N,PU}}$ 8 kHz [A]	$I_{2\text{N,PU}}$ 16 kHz [A]
SI6A061	5	4.5	3.5
SI6A062	2 × 5	2 × 4.5	2 × 3.5
SI6A161	12	10	6
SI6A162	2 × 12	2 × 10	2 × 6
SI6A261	22	20	10
SI6A262	2 × 25	2 × 20	2 × 10
SI6A361	50	40	—

Tab. 24: Nominal output current $I_{2\text{N,PU}}$ dependent on the clock frequency

3.2.2.5.2 Effect of the surrounding temperature

Derating as a function of the surrounding temperature is determined as follows:

- 0 °C to 45 °C: No restrictions ($D_T = 100\%$)
- 45 °C to 55 °C: Derating $-2.5\%/K$

Example

The drive controller needs to be operated at 50 °C.

The derating factor D_T is calculated as follows

$$D_T = 100\% - 5 \times 2.5\% = 87.5\%$$

3.2.2.5.3 Effect of the installation altitude

Derating as a function of the installation altitude is determined as follows:

- 0 m to 1000 m: No restriction ($D_{IA} = 100\%$)
- 1000 m to 2000 m: Derating $-1.5\%/100$ m

Example

The drive controller needs to be installed at an altitude of 1500 m above sea level.

The derating factor D_{IA} is calculated as follows:

$$D_{IA} = 100\% - 5 \times 1.5\% = 92.5\%$$

3.2.2.5.4 Calculating the derating

Follow these steps for the calculation:

1. Determine the highest clock frequency (f_{PWM}) that will be used during operation and use it to determine the nominal current $I_{2N,PU}$.
2. Determine the derating factors for installation altitude and surrounding temperature.
3. Calculate the reduced nominal current $I_{2N,PU(red)}$ in accordance with the following formula:

$$I_{2N,PU(red)} = I_{2N,PU} \times D_T \times D_{IA}$$

Example

A drive controller of type SI6A061 needs to be operated at a clock frequency of 8 kHz at an altitude of 1500 m above sea level and a surrounding temperature of 50 °C.

The nominal current of the SI6A061 at 8 kHz is 4.5 A. The derating factor D_T is calculated as follows:

$$D_T = 100\% - 5 \times 2.5\% = 87.5\%$$

The derating factor D_{IA} is calculated as follows:

$$D_{IA} = 100\% - 5 \times 1.5\% = 92.5\%$$

The output current of importance for the project configuration is:

$$I_{2N,PU(red)} = 4.5 \text{ A} \times 0.875 \times 0.925 = 3.64 \text{ A}$$

3.2.2.6 Dimensions

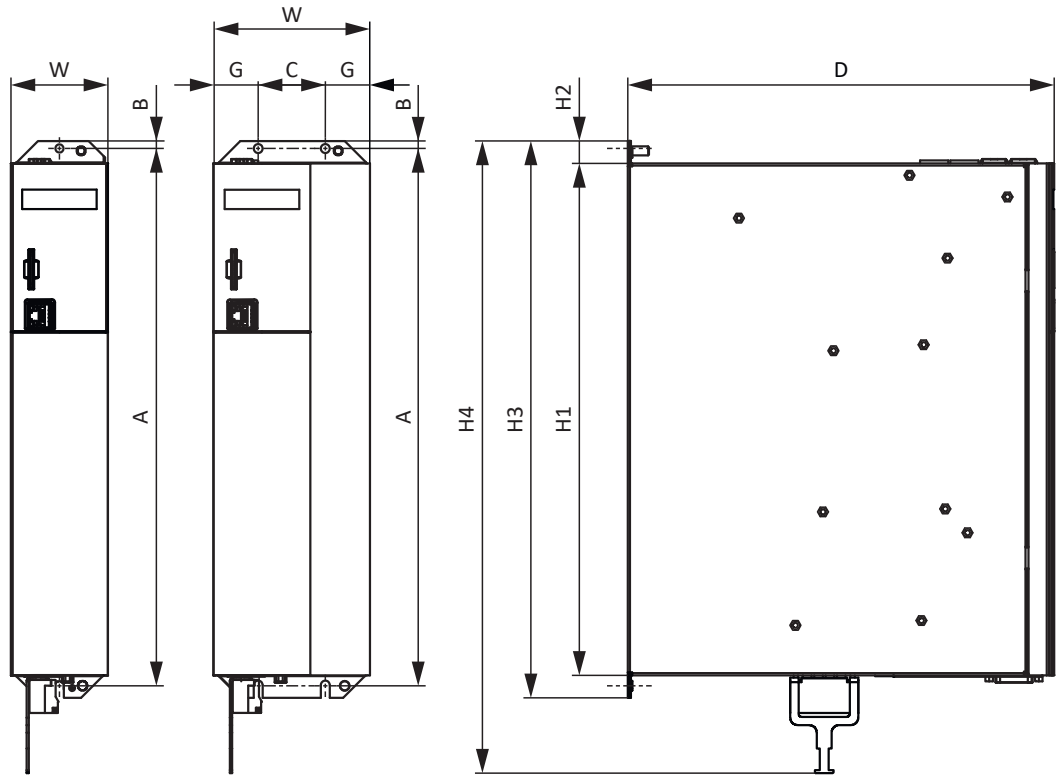

Fig. 2: SI6 dimensional drawing

Dimension		SI6A061 SI6A062	SI6A161 SI6A162	SI6A261	SI6A262	SI6A361
Drive controllers	Width	W	45	65	105	
	Depth	D	265	286		
	Body height	H1	343			
	Fastening clip height	H2	15			
	Height incl. fastening clips	H3	373			
	Total height incl. shield connection	H4	423			
Fastening holes (M5)	Vertical distance	A	360+2			
	Vertical distance to the upper edge	B	5			
	Horizontal spacing of the fastening holes	C	—		45	
	Horizontal distance to the side edge	G	—		30	

Tab. 25: SI6 dimensions [mm]

3.2.2.7 Weight

Type	Weight without packaging [g]	Weight with packaging [g]
SI6A061	2980	4600
SI6A062	3460	5060
SI6A161	3880	5260
SI6A162	4820	6240
SI6A261	4760	6200
SI6A262	6240	7420
SI6A361	6180	7360

Tab. 26: SI6 weight [g]

3.2.3 Supply module

The following section contains specifications for the electrical data, dimensions and weight of the PS6 supply module.

3.2.3.1 Type designation

PS	6	A	2	4
----	---	---	---	---

Tab. 27: Example code for supply module type designation

Code	Designation	Design
PS	Series	
6	Generation	Generation 6
A	Version	
2 – 4	Size	
4	Power output stage	

Tab. 28: Meaning of the example code

3.2.3.2 Sizes

Type	ID No.	Size
PS6A24	56650	Size 2
PS6A34	56651	Size 3
PS6A44	138679	Size 4

Tab. 29: Available PS6 types and sizes



PS6 in sizes 2 to 4

Note that the basic device is delivered without terminals. Suitable terminal sets are available separately for each size.

3.2.3.3 Electrical data

The electrical data of the available PS6 sizes as well as the properties of the brake chopper can be found in the following sections.

Information

The STO safety function is available for safe stopping as an alternative to continuous, cyclical power-on/power-off operation.

An explanation of the symbols used for formulas can be found in Chapter [\[9.1 \]](#).

3.2.3.3.1 Control unit

Electrical data	All types
U_{1CU}	24 V _{DC} , +20%/–15%
I_{1maxCU}	0.5 A

Tab. 30: Control unit electrical data

3.2.3.3.2 Power unit: Size 2

Electrical data	PS6A24
U_{1PU}	3 × 400 V _{AC} , +32%/–50%, 50/60 Hz; 3 × 480 V _{AC} , +10%/–58%, 50/60 Hz
$U_{2PU,ZK}$	$\sqrt{2} \times U_{1PU}$
$P_{N,PU}$	10 kW
$I_{1N,PU}$	25 A
I_{1maxPU}	$I_{1N,PU} \times 180\%$ for 5 s; $I_{1N,PU} \times 150\%$ for 30 s
$C_{N,PU}$	5000 μF

Tab. 31: PS6 electrical data, size 2

3.2.3.3.3 Power unit: Size 3

Electrical data	PS6A34
U_{1PU}	3 × 400 V _{AC} , +32%/–50%, 50/60 Hz; 3 × 480 V _{AC} , +10%/–58%, 50/60 Hz
$U_{2PU,ZK}$	$\sqrt{2} \times U_{1PU}$
$P_{N,PU}$	20 kW
$I_{1N,PU}$	50 A
I_{1maxPU}	$I_{1N,PU} \times 180\%$ for 5 s; $I_{1N,PU} \times 150\%$ for 30 s
$C_{N,PU}$	10000 μF

Tab. 32: PS6 electrical data, size 3

3.2.3.3.4 Power unit: Size 4

Electrical data	PS6A44
U_{1PU}	3 × 400 V _{AC} , +32%/–50%, 50/60 Hz; 3 × 480 V _{AC} , +10%/–58%, 50/60 Hz
$U_{2PU,ZK}$	$\sqrt{2} \times U_{1PU}$
$P_{N,PU}$	50 kW
$I_{1N,PU}$	92 A
I_{1maxPU}	$I_{1N,PU} \times 180\%$ for 5 s; $I_{1N,PU} \times 150\%$ for 30 s
$C_{N,PU}$	20000 μF

Tab. 33: PS6 electrical data, size 4

3.2.3.3.5 Parallel connection

Only supply modules of either size 2 or 3 may be connected in parallel.

The power and current increase if supply modules are connected in parallel. Take into account that the total is derated by a factor of 0.8 in doing so.

The charging capacity of the supply modules can be increased by a parallel connection only if the power grid supply is connected to all supply modules simultaneously. Increasing the charging capacity also requires derating the total by a factor of 0.8.

The following table shows example combinations for parallel connection.

Electrical data	2 x PS6A24	3 x PS6A24	2 x PS6A34	3 x PS6A34
$P_{N,PU}$	16 kW	24 kW	32 kW	48 kW
$I_{1N,PU}$	40 A	60 A	80 A	120 A
C_{maxPU}	8000 μ F	12000 μ F	16000 μ F	24000 μ F

Tab. 34: Electrical data for parallel connection: Example combinations

The following general conditions apply to the parallel connection of several PS6 supply modules:

- Only supply modules of size 2 or 3 may be connected in parallel.
- Only the same sizes may be connected in parallel.
- You can connect a maximum of 3 PS6A34 in parallel.

3.2.3.3.6 Brake chopper

Electrical data	PS6A24	PS6A34
U_{onCH}	780 – 800 V _{DC}	
U_{offCH}	740 – 760 V _{DC}	
R_{2minRB}	22 Ω	
P_{maxRB}	29.1 kW	
P_{effRB}	27.2 kW	

Tab. 35: Brake chopper electrical data, size 2 and 3

Electrical data	PS6A44
U_{onCH}	780 – 800 V _{DC}
U_{offCH}	740 – 760 V _{DC}
R_{2minRB}	9.5 Ω
P_{maxRB}	67.3 kW
P_{effRB}	27.2 kW

Tab. 36: Brake chopper electrical data, size 4

3.2.3.3.7 Fast discharge

Fast discharge is activated when no supply voltage is present for 20 s and the DC link voltage has reduced over this time. For active fast discharge, the DC link is discharged via the brake chopper and the braking resistor. Fast discharge does not take place for constant or increasing DC link voltage as this behavior indicates a second supply module in the DC link group. If the temperature sensor of the braking resistor is active, the fast discharge also remains off.

3.2.3.4 Dimensions

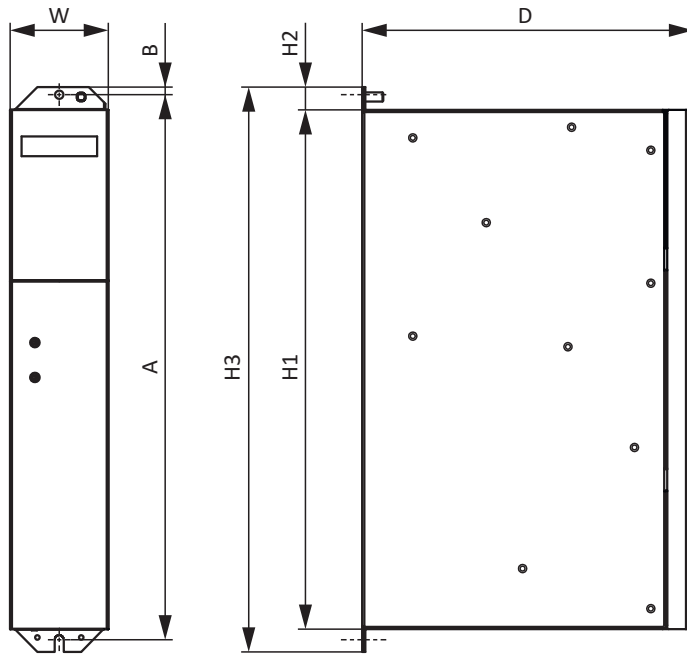

Fig. 3: PS6A24, PS6A34 dimensional drawing

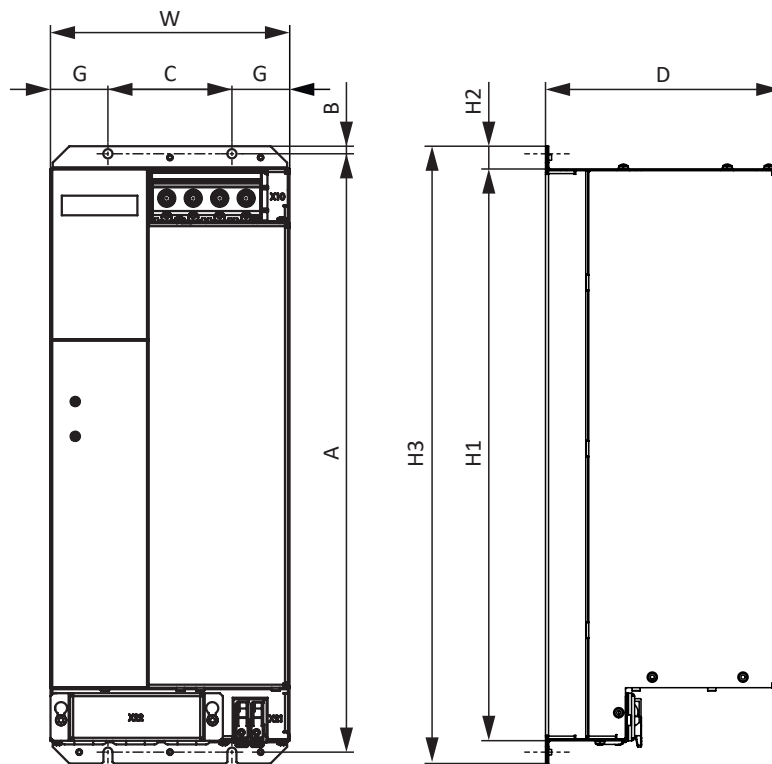

Fig. 4: PS6A44 dimensional drawing

Dimension			PS6A24	PS6A34	PS6A44
Supply module	Width	W	45	65	158
	Depth	D	204	219	156.5
	Body height	H1	343		378
	Fastening clip height	H2	15		
	Height incl. fastening clips	H3	373		408
Fastening holes (M5)	Vertical distance	A	360+2		396+2
	Vertical distance to the upper edge	B	5		
	Horizontal spacing of the fastening holes	C	—		82
	Horizontal distance to the side edge	G	—		38

Tab. 37: PS6 dimensions [mm]

3.2.3.5 Weight

Type	Weight without packaging [g]	Weight with packaging [g]
PS6A24	2680	4180
PS6A34	3820	4920
PS6A44	6640	7640

Tab. 38: PS6 weight [g]

3.2.4 DC link connection

The following section contains specifications for the electrical data, dimensions and weight of the DL6B modules Quick DC-Link.

3.2.4.1 General technical data

The following information applies to all Quick DC-Link modules and corresponds to the general technical data for the base device.

Device features	
Protection class of the device	IP20 (if built over with drive controller or supply module)
Protection class	Protection class I in accordance with EN 61140 (if built over with drive controller or supply module)
Protection class of the installation space	At least IP54

Tab. 39: Device features

Transport and storage conditions	
Storage/ transport temperature	-20 °C to +70 °C Maximum change: 20 K/h
Relative humidity	Maximum relative humidity 85%, non-condensing
Vibration (transport) in accordance with EN 60068-2-6	5 Hz ≤ f ≤ 9 Hz: 3.5 mm 9 Hz ≤ f ≤ 200 Hz: 10 m/s ² 200 Hz ≤ f ≤ 500 Hz: 15 m/s ²
Fall height for freefall ⁷ Weight < 100 kg in accordance with EN 61800-2 (or IEC 60721-3-2, class 2M1)	0.25 m

Tab. 40: Transport and storage conditions

Operating conditions	
Surrounding temperature during operation	0 °C to 45 °C with nominal data 45 °C to 55 °C with derating -2.5% / K
Relative humidity	Maximum relative humidity 85%, non-condensing
Installation altitude	0 m to 1000 m above sea level without restrictions 1000 m to 2000 m above sea level with -1.5%/100 m derating
Pollution degree	Pollution degree 2 in accordance with EN 50178
Vibration (operation) in accordance with EN 60068-2-6	5 Hz ≤ f ≤ 9 Hz: 0.35 mm 9 Hz ≤ f ≤ 200 Hz: 1 m/s ²

Tab. 41: Operating conditions

3.2.4.2 assignment to DL6B – SI6 and PS6

DL6B is available in the following designs suitable for the individual drive controller types and supply module types:

Type	DL6B10	DL6B11	DL6B12	DL6B20	DL6B21	DL6B22
ID No.	56655	56656	56663	56657	56658	5050114
SI6A061	X	—	—	—	—	—
SI6A062	X	—	—	—	—	—
SI6A161	—	X	—	—	—	—
SI6A162	—	X	—	—	—	—
SI6A261	—	X	—	—	—	—
SI6A262	—	—	X	—	—	—
SI6A361	—	—	X	—	—	—
PS6A24	—	—	—	X	—	—
PS6A34	—	—	—	—	X	—
PS6A44	—	—	—	—	—	X

Tab. 42: DL6B assignment to SI6 and PS6

3.2.4.3 Dimensions

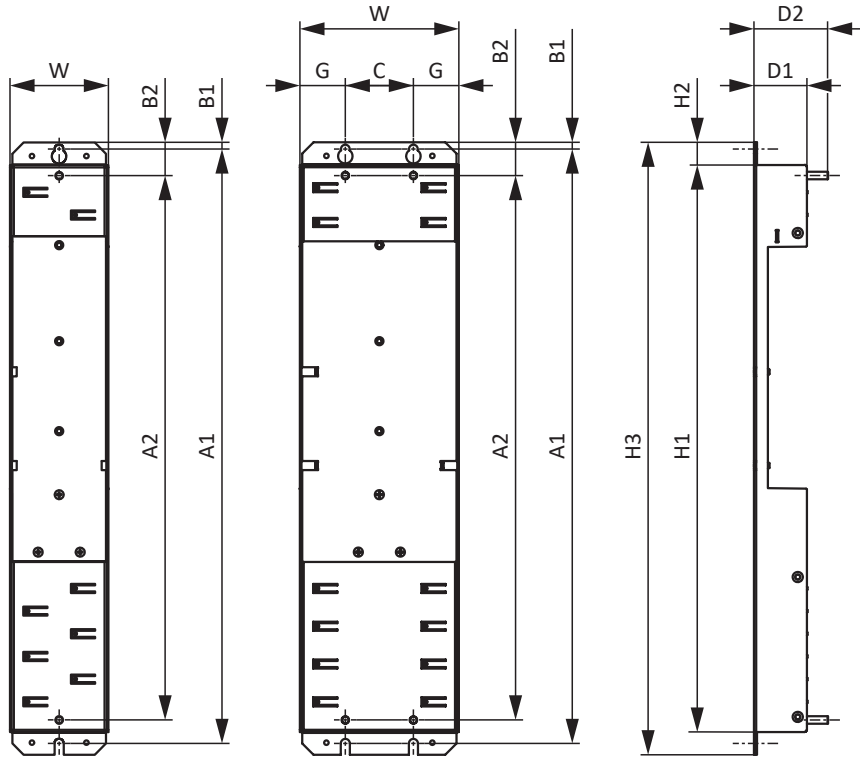

Fig. 5: Dimensional drawing of DL6B10 to DL6B21

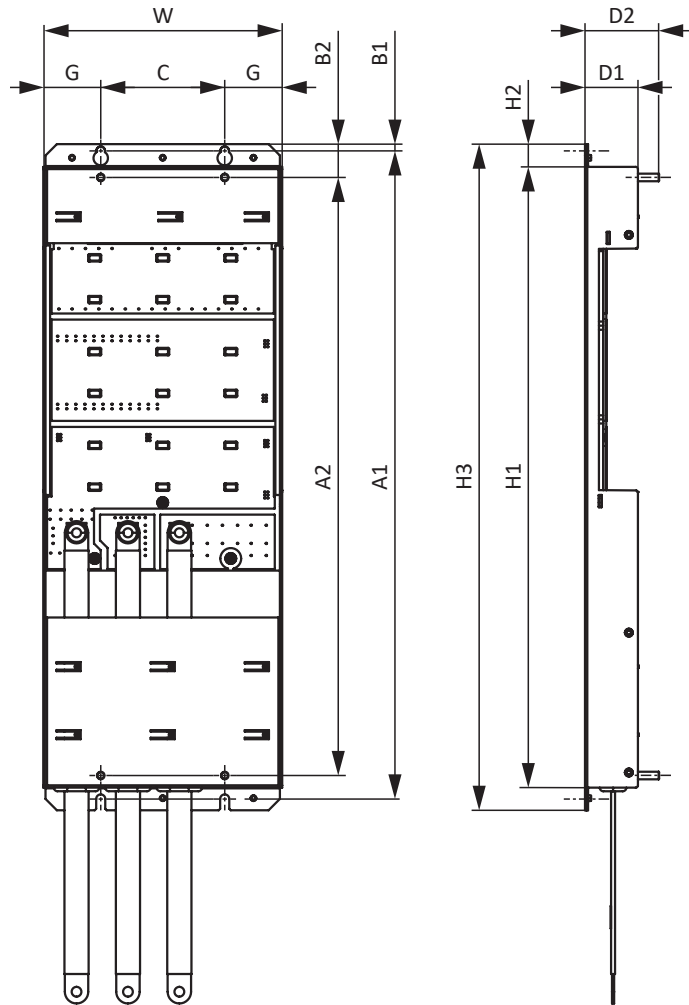

Fig. 6: DL6B22 dimensional drawing

Dimension			DL6B10 DL6B20	DL6B11 DL6B21	DL6B12	DL6B22
Quick DC-Link	Width	W	45	65	105	158
	Depth	D1	35			
	Depth incl. attachment bolts	D2	49			
	Height	H1	375			410.5
	Fastening clip height	H2	15			
	Height incl. fastening clips	H3	405			440.5
Fastening holes	Vertical distance (wall mounting)	A1	393+2			429+2
	Vertical distance (module mounting)	A2	360			396
	Vertical distance to the upper edge	B1	4.5			
	Vertical distance to the upper edge	B2	22			
	Horizontal spacing of the fas- tening holes	C	—		45	82
	Horizontal distance to the side edge	G	—		30	38

Tab. 43: DL6B dimensions [mm]

3.2.4.4 Weight

Type	Weight without packaging [g]	Weight with packaging [g]
DL6B10	440	480
DL6B11	560	600
DL6B12	880	920
DL6B20	480	520
DL6B21	740	780
DL6B22	1400	1440

Tab. 44: DL6B weight [g]

3.2.5 Minimum clearances

Drive controllers and supply modules

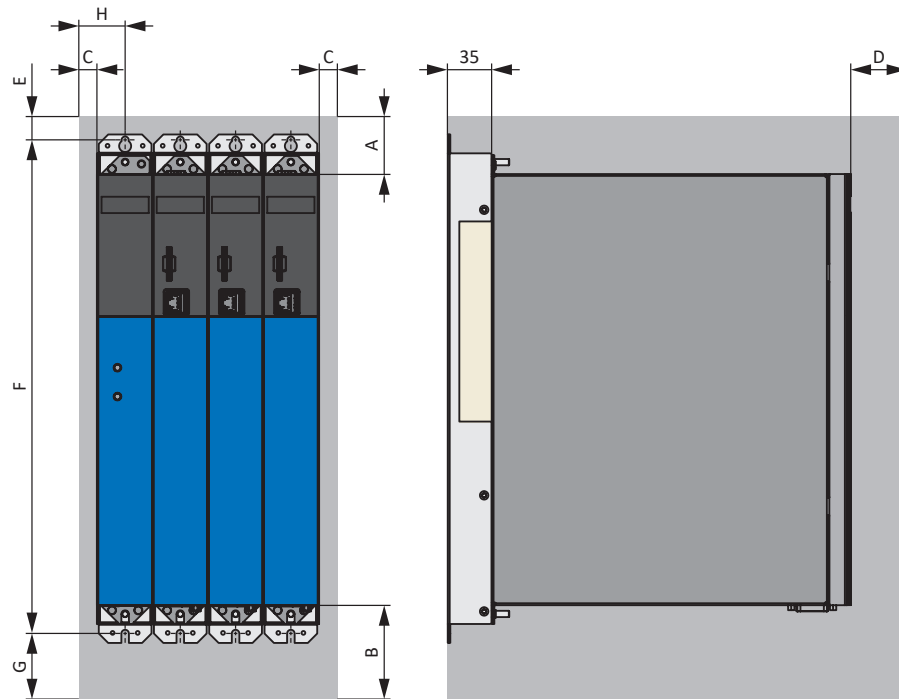

Fig. 7: Minimum clearances for drive controllers in combination with a PS6A24 or PS6A34 supply module

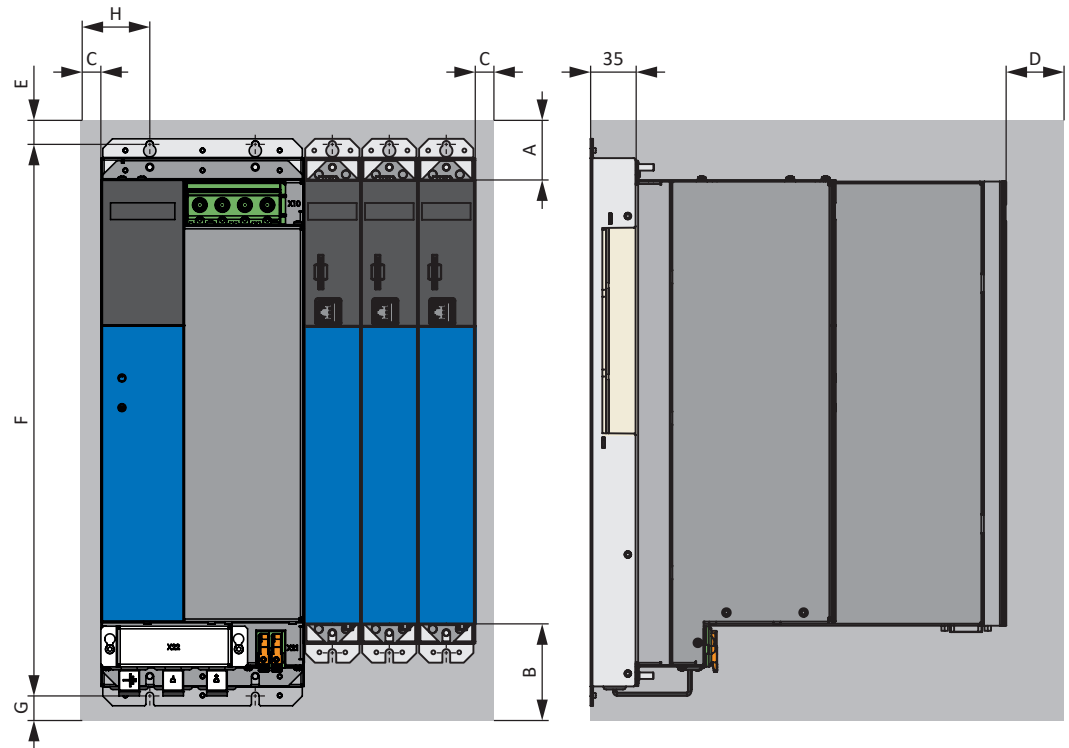

Fig. 8: Minimum clearances for drive controllers in combination with a PS6A44 supply module

The specified dimensions refer to the outside edges of the drive controller or supply module including the Quick DC-Link rear section module.

Minimum clearance	A (above)	B (below)	C (on the side)	D (in front)
All sizes	100	200	5	50 ⁸

Tab. 45: Minimum clearances [mm]

Dimension	E	F	G	H
PS6A24	73.5	393+2	approx. 174.5	27.5
PS6A34	73.5	393+2	approx. 174.5	37.5
PS6A44	73.5	429+2	approx. 138.5	43

Tab. 46: Dimensions [mm]

Chokes and filters

Avoid installation below drive controllers or supply modules. For installation in a control cabinet, a distance of approximately 100 mm to other neighboring components is recommended. This distance ensures proper heat dissipation for chokes and filters.

Braking resistors

Avoid installation below drive controllers or supply modules. In order for heated air to flow out unimpeded, a minimum clearance of approximately 200 mm must be maintained in relation to neighboring components or walls and approximately 300 mm must be maintained to components above or ceilings.

⁸ Minimum clearance to be taken into account for permanent connection of the X9 service interface

3.3 Drive controller/motor combinations

An explanation of the symbols used for formulas can be found in Chapter [▶ 9.1](#).

EZ synchronous servo motor ($n_n = 2000$ rpm) – SI6

						SI6A061	SI6A161	SI6A261	SI6A262	SI6A361	SI6A061	SI6A161	SI6A261	SI6A262	SI6A361
						SI6A062	SI6A162				SI6A062	SI6A162			
						$I_{2N,PU}$ [A] ($f_{PWM,PU} = 4$ kHz)					$I_{2N,PU}$ [A] ($f_{PWM,PU} = 8$ kHz)				
K_{EM} [V/1000 rpm]	M_N [Nm]	I_N [A]	M_0 [Nm]	I_0 [A]		5	12	22	25	50	4.5	10	20	20	40

IC 410 convection cooling						$I_{2N,PU} / I_0$										
EZ805U	142	43.7	25.9	66.1	37.9					1.3						1.1

EZ synchronous servo motor ($n_n = 3000$ rpm) – SI6

						SI6A061	SI6A161	SI6A261	SI6A262	SI6A361	SI6A061	SI6A161	SI6A261	SI6A262	SI6A361
						SI6A062	SI6A162				SI6A062	SI6A162			
						$I_{2N,PU}$ [A] ($f_{PWM,PU} = 4$ kHz)					$I_{2N,PU}$ [A] ($f_{PWM,PU} = 8$ kHz)				
K_{EM} [V/1000 rpm]	M_N [Nm]	I_N [A]	M_0 [Nm]	I_0 [A]		5	12	22	25	50	4.5	10	20	20	40

IC 410 convection cooling						$I_{2N,PU} / I_0$									
EZ301U	40	0.93	1.99	0.95	2.02	2.5					2.2				
EZ302U	86	1.59	1.6	1.68	1.67	3.0					2.7				
EZ303U	109	2.07	1.63	2.19	1.71	2.9					2.6				
EZ401U	96	2.8	2.74	3	2.88	1.7					1.6				
EZ402U	94	4.7	4.4	5.2	4.8	1.0						2.1			
EZ404U	116	6.9	5.8	8.6	6.6		1.8					1.5			
EZ501U	97	4.3	3.74	4.7	4	1.3					1.1				
EZ502U	121	7.4	5.46	8	5.76		2.1					1.7			
EZ503U	119	9.7	6.9	11.1	7.67		1.6					1.3			
EZ505U	141	13.5	8.8	16	10		1.2	2.0				1.0	2.0	2.0	
EZ701U	95	7.4	7.2	8.3	8		1.5					1.3			
EZ702U	133	12	8.2	14.4	9.6		1.3					1.0	2.1	2.1	
EZ703U	122	16.5	11.4	20.8	14			1.6	1.8				1.4	1.4	
EZ705U	140	21.3	14.2	30.2	19.5			1.1	1.3				1.0	1.0	2.1
EZ802U	136	22.3	13.9	37.1	22.3				1.1						1.8
EZ803U	131	26.6	17.7	48.2	31.1					1.6					1.3

IC 416 forced ventilation						$I_{2N,PU} / I_0$									
EZ401B	96	3.4	3.4	3.7	3.6	1.4					1.3				
EZ402B	94	5.9	5.5	6.3	5.8		2.1					1.7			
EZ404B	116	10.2	8.2	11.2	8.7		1.4					1.1		2.0	
EZ501B	97	5.4	4.7	5.8	5	1.0						2.0			
EZ502B	121	10.3	7.8	11.2	8.16		1.5					1.2			
EZ503B	119	14.4	10.9	15.9	11.8		1.0	1.9	2.1				1.7	1.7	
EZ505B	141	20.2	13.7	23.4	14.7			1.5	1.7				1.4	1.4	
EZ701B	95	9.7	9.5	10.5	10		1.2	2.2				1.0	2.0	2.0	
EZ702B	133	16.6	11.8	19.3	12.9			1.7	1.9				1.6	1.6	
EZ703B	122	24	18.2	28	20			1.1	1.3				1.0	1.0	2.0
EZ705B	140	33.8	22.9	41.8	26.5					1.9					1.5
EZ802B	136	34.3	26.5	47.9	28.9					1.7					1.4
EZ803B	131	49	35.9	66.7	42.3					1.2					

EZ synchronous servo motor ($n_n = 4500$ rpm) – SI6

						SI6A061 SI6A062	SI6A161 SI6A162	SI6A261	SI6A262	SI6A361	SI6A061 SI6A062	SI6A161 SI6A162	SI6A261	SI6A262	SI6A361
						$I_{2N,PU}$ [A] ($f_{PWM,PU} = 4$ kHz)					$I_{2N,PU}$ [A] ($f_{PWM,PU} = 8$ kHz)				
	K_{EM} [V/1000 rpm]	M_N [Nm]	I_N [A]	M_0 [Nm]	I_0 [A]	5	12	22	25	50	4.5	10	20	20	40

IC 410 convection cooling

						$I_{2N,PU} / I_0$									
EZ505U	103	9.5	8.9	15.3	13.4			1.6	1.9				1.5	1.5	
EZ703U	99	12.1	11.5	20	17.8			1.2	1.4				1.1	1.1	
EZ705U	106	16.4	14.8	30	25.2					2.0					1.6
EZ802U	90	10.5	11.2	34.5	33.3					1.5					1.2

IC 416 forced ventilation

						$I_{2N,PU} / I_0$									
EZ505B	103	16.4	16.4	22	19.4			1.1	1.3				1.0	1.0	2.1
EZ703B	99	19.8	20.3	27.2	24.2				1.0	2.1					1.7
EZ705B	106	27.7	25.4	39.4	32.8					1.5					1.2
EZ802B	90	30.6	30.5	47.4	45.1					1.1					

EZ synchronous servo motor ($n_n = 6000$ rpm) – SI6

						SI6A061 SI6A062	SI6A161 SI6A162	SI6A261	SI6A262	SI6A361	SI6A061 SI6A062	SI6A161 SI6A162	SI6A261	SI6A262	SI6A361
						$I_{2N,PU}$ [A] ($f_{PWM,PU} = 4$ kHz)					$I_{2N,PU}$ [A] ($f_{PWM,PU} = 8$ kHz)				
	K_{EM} [V/1000 rpm]	M_N [Nm]	I_N [A]	M_0 [Nm]	I_0 [A]	5	12	22	25	50	4.5	10	20	20	40

IC 410 convection cooling

						$I_{2N,PU} / I_0$									
EZ202U	40	0.44	1.07	0.48	1.12	4.5					4.0				
EZ203U	40	0.64	1.53	0.73	1.65	3.0					2.7				
EZ301U	40	0.89	1.93	0.95	2.02	2.5					2.2				
EZ302U	42	1.5	3.18	1.68	3.48	1.4					1.3				
EZ303U	55	1.96	3.17	2.25	3.55	1.4					1.3				
EZ401U	47	2.3	4.56	2.8	5.36		2.2					1.9			
EZ402U	60	3.5	5.65	4.9	7.43		1.6					1.3			
EZ404U	78	5.8	7.18	8.4	9.78		1.2					1.0	2.0	2.0	
EZ501U	68	3.4	4.77	4.4	5.8		2.1					1.7			
EZ502U	72	5.2	7.35	7.8	9.8		1.2					1.0	2.0	2.0	
EZ503U	84	6.2	7.64	10.6	11.6		1.0	1.9	2.2				1.7	1.7	
EZ701U	76	5.2	6.68	7.9	9.38		1.3					1.1	2.1	2.1	
EZ702U	82	7.2	8.96	14.3	16.5			1.3	1.5				1.2	1.2	

IC 416 forced ventilation

						$I_{2N,PU} / I_0$									
EZ401B	47	2.9	5.62	3.5	6.83		1.8					1.5			
EZ402B	60	5.1	7.88	6.4	9.34		1.3					1.1	2.1	2.1	
EZ404B	78	8	9.98	10.5	12		1.0	1.8	2.1				1.7	1.7	
EZ501B	68	4.5	6.7	5.7	7.5		1.6					1.3			
EZ502B	72	8.2	11.4	10.5	13.4			1.6	1.9				1.5	1.5	
EZ503B	84	10.4	13.5	14.8	15.9			1.4	1.6				1.3	1.3	
EZ701B	76	7.5	10.6	10.2	12.4			1.8	2.0				1.6	1.6	
EZ702B	82	12.5	16.7	19.3	22.1				1.1						1.8

3.4 Accessories

You can find information about the available accessories in the following chapters.

3.4.1 Safety technology

Information

The drive controller is delivered in the standard design without safety technology (option SZ6). If you want a drive controller with integrated safety technology, you must order it together with the drive controller. The safety modules are an integrated part of the drive controllers and must not be modified.

SZ6 option – Without safety technology

Included in the standard version.

ID No. 56660

Design without safety technology.

SR6 safety module – STO using terminals

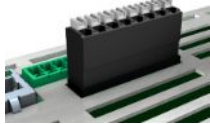

ID No. 56661

Optional accessory for the use of the Safe Torque Off safety function (STO) in safety-relevant applications (PL e, SIL 3) in accordance with EN ISO 13849-1 and EN 61800-5-2. Connection to a higher-level safety circuit via terminal X12.

SY6 safety module – STO and SS1 using FSoE



ID No. 56662

Optional accessory for the use of the Safe Torque Off (STO) and Safe Stop 1 (SS1) safety functions in safety-relevant applications (PL e, SIL 3) in accordance with EN ISO 13849-1 and EN 61800-5-2. Connection to the higher-level safety circuit using Fail Safe over EtherCAT (FSoE).

SU6 safety module – STO and SS1 using PROFIsafe



ID No. 56696

Optional accessory for the use of the Safe Torque Off (STO) and Safe Stop 1 (SS1) safety functions in safety-relevant applications (PL e, SIL 3) in accordance with EN ISO 13849-1 and EN 61800-5-2. Connection to a higher-level safety circuit via PROFINET (PROFIsafe).

3.4.2 Communication

The drive controller has two interfaces for the fieldbus connection on the top of the device as well as an Ethernet service interface on the front of the device. Cables for the connection are available separately.

EtherCAT or PROFINET fieldbus system

EtherCAT 

PROFI
NET 

Please specify the desired fieldbus system when placing your order for the base device, since the fieldbus communication is defined using the firmware.

EtherCAT cables



Ethernet patch cable, CAT5e, yellow.
The following designs are available:
ID No. 49313: Length approx. 0.25 m.
ID No. 49314: Length approx. 0.5 m.

PC connecting cables



ID No. 49857
Cable for connecting the X9 service interface to the PC, CAT5e, blue, 5 m.

USB 2.0 Ethernet adapter



ID No. 49940
Adapter for connecting Ethernet to a USB port.

3.4.3 Terminal set

For the connection, you need suitable terminal sets for each PS6 supply module and each SI6 drive controller.

Terminal set for supply module

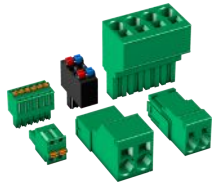

(Fig. similar)

The following designs are available:

- ID No. 138660
Terminal set for PS6A24.
- ID No. 138661
Terminal set for PS6A34.
- ID No. 5050112
Terminal set for PS6A44.

Terminal set for drive controllers – SZ6 option (without safety technology), SU6 option (STO and SS1 using PROFIsafe) or SY6 option (STO and SS1 using FSoE)

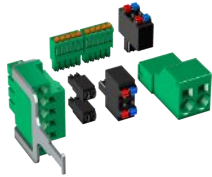

(Fig. similar)

The following designs are available:

- ID No. 138655
Terminal set for SI6A061Z/U/Y.
- ID No. 138656
Terminal set for SI6A062Z/U/Y.
- ID No. 138657
Terminal set for SI6A161Z/U/Y.
- ID No. 138658
Terminal set for SI6A162Z/U/Y.
- ID No. 138659
Terminal set for SI6A261Z/U/Y.
- ID No. 138662
Terminal set for SI6A262Z/U/Y.
- ID No. 138663
Terminal set for SI6A361Z/U/Y.

Terminal set for drive controllers – SR6 option (STO via terminals)

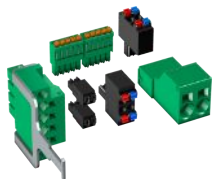

(Fig. similar)

The following designs are available:

- ID No. 138683
Terminal set for SI6A061R.
- ID No. 138684
Terminal set for SI6A062R.
- ID No. 138685
Terminal set for SI6A161R.
- ID No. 138686
Terminal set for SI6A162R.
- ID No. 138687
Terminal set for SI6A261R.
- ID No. 138688
Terminal set for SI6A262R.
- ID No. 138689
Terminal set for SI6A361R.

3.4.4 DC link connection

For the energy supply of the existing networked drive controllers, you need suitable Quick DC-Link modules of type DL6B for each PS6 supply module and each SI6 drive controller.

For the horizontal connection, you receive DL6B rear section modules in various designs, matched to the size of the drive controller or supply module.

The quick fastening clamps for attaching the copper rails and an insulation connection piece are contained in the scope of delivery. The copper rails are not included in the scope of delivery. These must have a cross-section of 5 x 12 mm. Insulation end sections are available separately.

Quick DC-Link DL6B for drive controller

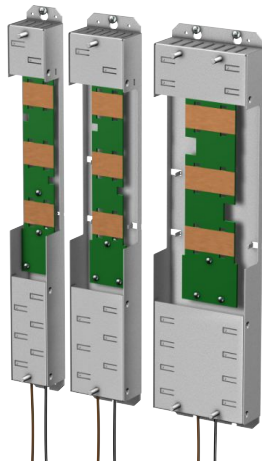

The following designs are available:

DL6B10

ID No. 56655

Rear section module for size 0 drive controller:

SI6A061 and SI6A062

DL6B11

ID No. 56656

Rear section module for size 1 or 2 (single-axis controller) drive controller:

SI6A161, SI6A162 and SI6A261

DL6B12

ID No. 56663

Rear section module for size 2 (double-axis controller) or 3 drive controller:

SI6A262 and SI6A361

Quick DC-Link DL6B for supply module

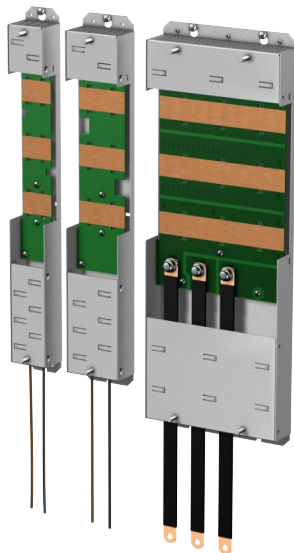

The following designs are available:

DL6B20

ID No. 56657

Rear section module for size 2 supply module:

PS6A24

DL6B21

ID No. 56658

Rear section module for size 3 supply module:

PS6A34

DL6B22

ID No. 5050114

Rear section module for size 4 supply module:

PS6A44

Quick DC-Link DL6B insulation end section



ID No. 56659

Insulation end sections for the left and right termination of the group, 2 pcs.

3.4.5 Braking resistor

In addition to the supply modules, STOBBER offers braking resistors in the various sizes and performance classes described below. For the selection, note the minimum permitted braking resistors specified in the technical data of the supply modules. In the event of a fault, such as a defective brake chopper, the supply module must be disconnected from the power supply.

3.4.5.1 Braking resistor assignment – PS6

Type	KWADQU 420×91 with MWS306L	KWADQU 420×91 with MWS310L	FZZMQU 400×65	FGFKQU 31005	FGFKQU 31009	FGFKQU 31114
ID No.	138675	138676	56635	56636	5050115	5050116
PS6A24	(—)	(—)	(X)	X	—	—
PS6A34	(—)	(—)	(X)	X	—	—
PS6A44	(—)	(—)	(—)	(X)	X	X

Tab. 47: Braking resistor assignment to PS6 supply module

- X Recommended
- (X) Possible
- (—) Useful under certain conditions
- Not possible

3.4.5.2 KWADQU flat resistor

The braking resistor is available with two different mounting bracket sets (MWS).

Properties

Specification	KWADQU 420×91 with MWS306L	KWADQU 420×91 with MWS310L
ID No.	138675	138676
Type	Flat resistor with temperature switch (incl. mounting bracket)	
Resistance [Ω]	100 \pm 10%	
Thermal drift	\pm 10%	
Power [W]	600	
Thermal time constant τ_{th} [s]	60	
Pulse power for < 1 s [kW]	13	
U_{max} [V]	848	
Cable design	FEP	
Cable length [mm]	500	
Conductor cross-section [AWG]	14/19 (1.9 mm ²)	
Weight without packaging [g]	2620	2770
Protection class	IP54	
Test symbols	cURus, CE, UKCA	

Tab. 48: KWADQU specification

Specification	Temperature switch
Switching capacity	2 A / 24 V _{DC} (DC11)
Nominal response temperature ϑ_{NAT}	180 °C \pm 5 K
Type	NC
Cable design	FEP
Cable length [mm]	500
Conductor cross-section [AWG]	22

Tab. 49: Temperature switch specification

Dimensions

Braking resistor with MWS306L

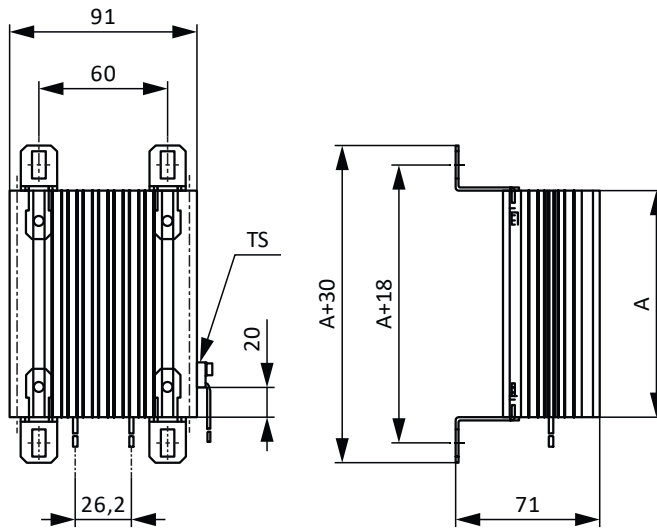

Fig. 9: KWADQU dimensional drawing with MWS306L

Braking resistor with MWS310L

The mounting brackets are freely positionable in the vertical direction over the entire length of the braking resistor.

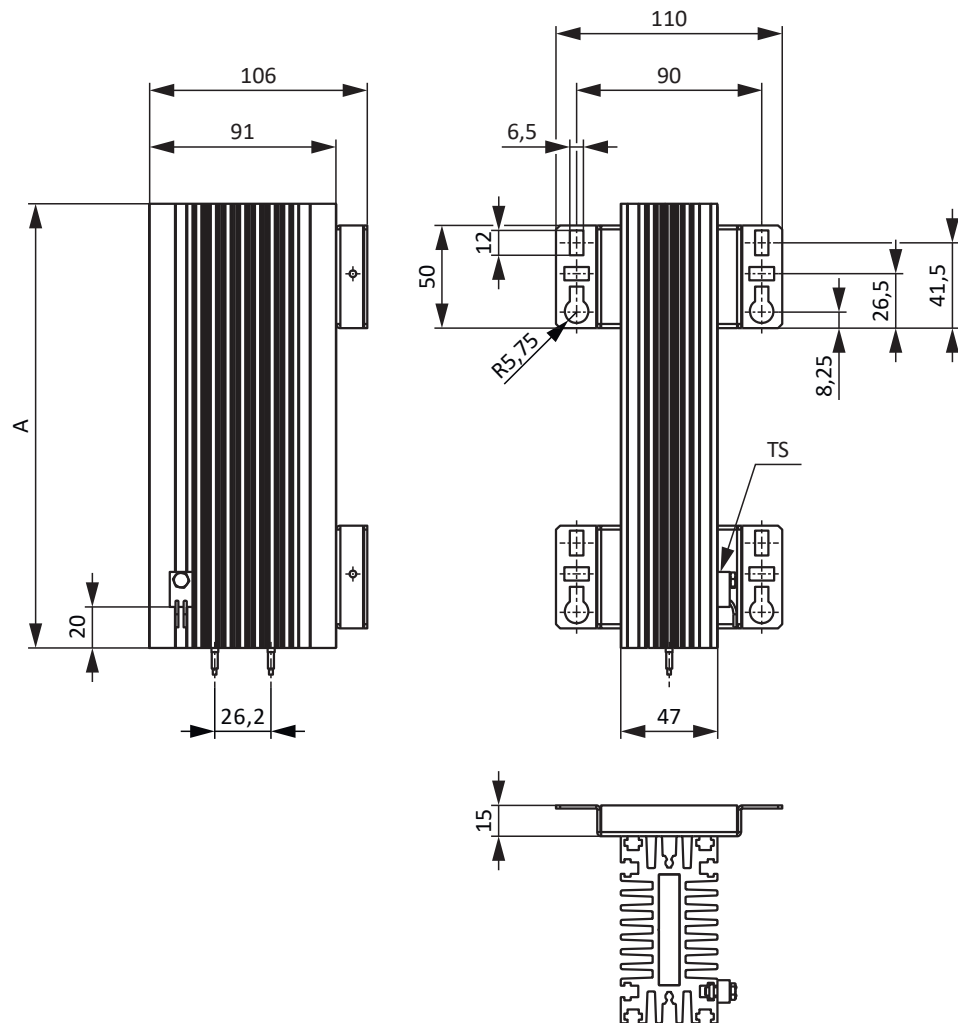

Fig. 10: KWADQU dimensional drawing with MWS310L

Dimension	KWADQU 420×91
A	420

Tab. 50: KWADQU dimensions [mm]

3.4.5.3 FZZMQU tubular fixed resistor

Properties

Specification	FZZMQU 400×65
ID No.	56635
Type	Tubular fixed resistor with temperature switch
Resistance [Ω]	47 \pm 10%
Thermal drift	\pm 10%
Power [W]	1200
Thermal time constant τ_{th} [s]	40
Pulse power for < 1 s [kW]	36
U_{max} [V]	848
Weight without packaging [g]	4200
Protection class	IP20
Test symbols	cURus, CE, UKCA

Tab. 51: FZZMQU specification

Specification	Temperature switch
Switching capacity	2 A / 24 V _{DC} (DC11)
Nominal response temperature ϑ_{NAT}	180 °C \pm 5 K
Type	NC
Cable design	FEP
Cable length [mm]	500
Conductor cross-section [AWG]	22

Tab. 52: Temperature switch specification

Dimensions

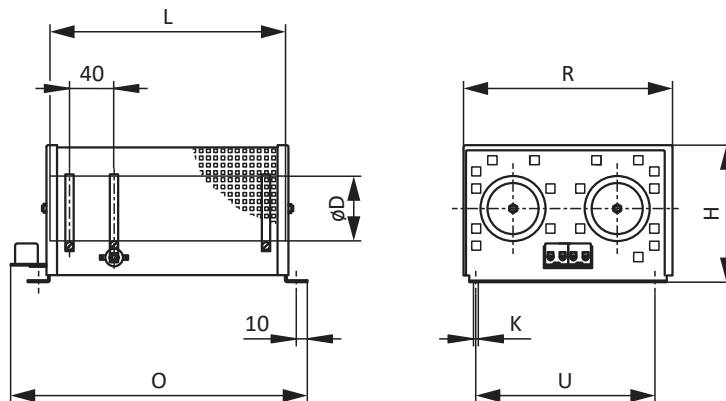

Fig. 11: FZZMQU dimensional drawing

Dimension	FZZMQU 400×65
L × D	400 × 65
H	120
K	6.5 × 12
O	485
R	185
U	150

Tab. 53: FZZMQU dimensions [mm]

3.4.5.4 FGFKQU steel-grid fixed resistor

Properties

Specification	FGFKQU 31005	FGFKQU 31009	FGFKQU 31114
ID No.	56636	5050115	5050116
Type	Steel-grid fixed resistor with temperature switch		
Resistance [Ω]	22 \pm 10%	14.4 \pm 10%	9.5 \pm 10%
Thermal drift	\pm 10%	\pm 10%	\pm 10%
Power [W]	2500	4500	7000
Thermal time constant τ_{th} [s]	30	30	20
Pulse power for < 1 s [kW]	50	90	140
U_{max} [V]	848		
Weight without packaging [g]	7500	9500	13000
Protection class	IP20		
Test symbols	cURus, CE, UKCA		

Tab. 54: FGFKQU specification

Specification	Temperature switch
Switching capacity	2 A / 24 V _{DC} (DC11)
Nominal response temperature ϑ_{NAT}	100 °C \pm 5 K
Type	NC
Cable design	FEP
Cable length [mm]	500
Conductor cross-section [AWG]	22

Tab. 55: Temperature switch specification

Dimensions

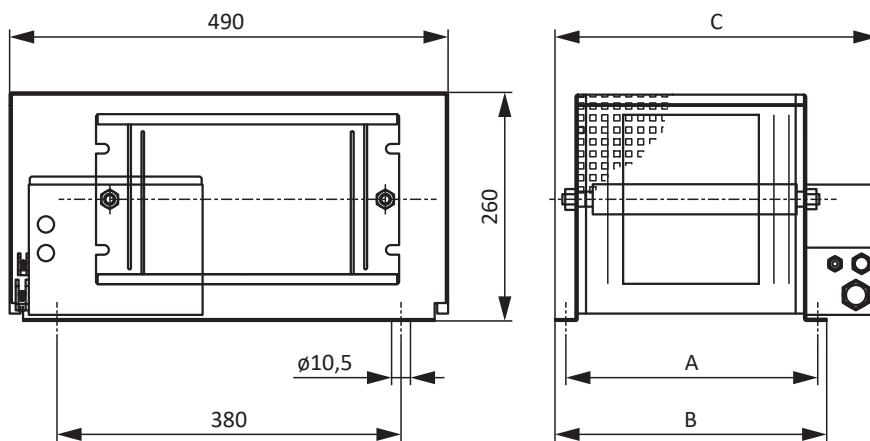

Fig. 12: FGFKQU dimensional drawing

Dimension	FGFKQU 31005	FGFKQU 31009	FGFKQU 31114
A	270	370	370
B	295	395	395
C	355	455	455

Tab. 56: FGFKQU dimensions [mm]

3.4.6 Choke

Technical specifications for suitable chokes can be found in the following chapters.

3.4.6.1 TEP power choke

Power chokes are used to dampen voltage and current peaks and reduce the load of the power feed-in of the supply modules.

Properties

Specification	TEP4010-2US00
ID No.	56528
Phases	3
Thermally allowed continuous current	100 A
Nominal current $I_{N,MF}$	90 A
Absolute loss P_V	103 W
Inductance	0.14 mH
Voltage range	3 × 400 V _{AC} +32%/−50% 3 × 480 V _{AC} +10%/−58%
Voltage drop U_k	2%
Frequency range	50/60 Hz
Protection class	IP00
Max. surrounding temperature $\vartheta_{amb,max}$	40 °C
Insulation class	B
Connection	Screw terminal
Connection type	Flexible with and without end sleeve
Max. conductor cross-section	6 – 35 mm ²
Tightening torque	2.5 Nm
Insulation stripping length	17 mm
Installation	Screws
Directive	EN 61558-2-20
UL Recognized Component (CAN; USA)	Yes
Test symbol, symbol	 cURus, CE,

Tab. 57: TEP specification

Dimensions

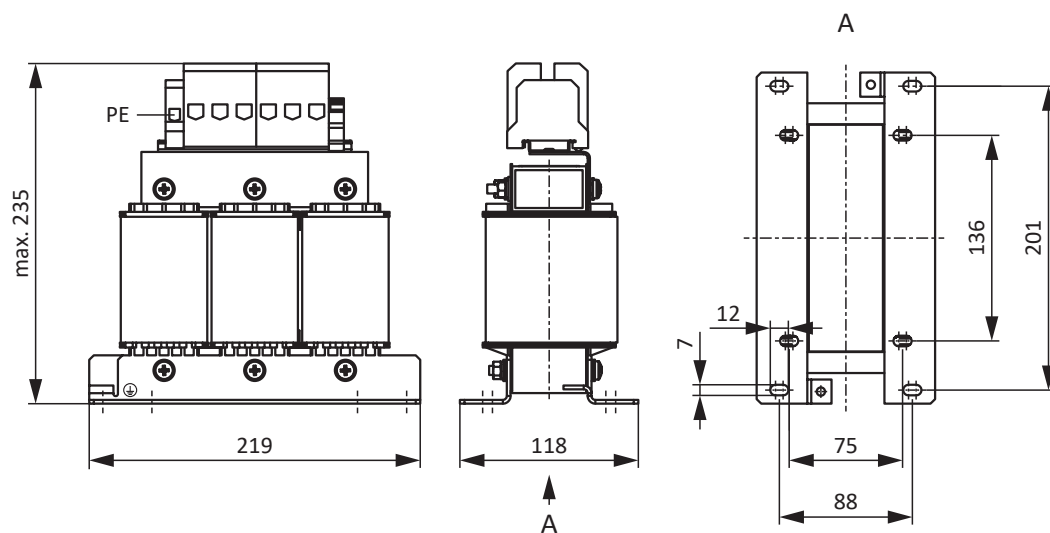

Fig. 13: Power choke dimensional drawing

Dimensions	TEP4010-2US00
Height [mm]	235
Width [mm]	219
Depth [mm]	118
Vertical distance 1 – fastening holes [mm]	201
Vertical distance 2 – Fastening holes [mm]	136
Horizontal distance 1 – fastening holes [mm]	88
Horizontal distance 2 – Fastening holes [mm]	75
Drill holes – Depth [mm]	7
Drill holes – Width [mm]	12
Screw connection – M	M6
Weight without packaging [g]	9900

Tab. 58: TEP dimensions and weight

3.4.6.2 TEP output choke

Output chokes are required for connecting size 0 to 2 drive controllers to synchronous servo motors or asynchronous motors from a cable length > 50 m in order to reduce interference pulses and protect the drive system. If Lean motors are connected, output chokes must not be used.

Information

The following technical data only applies to a rotating magnetic field frequency of 200 Hz. For example, this rotating magnetic field frequency is achieved with a motor with 4 pole pairs and a nominal speed of 3000 rpm. Always observe the specified derating for higher rotating magnetic field frequencies. Also observe the relationship with the clock frequency.

Properties

Specification	TEP3720-0ES41	TEP3820-0CS41	TEP4020-0RS41
ID No.	53188	53189	53190
Voltage range	3 × 0 to 480 V _{AC}		
Frequency range	0 – 200 Hz		
Nominal current I _{N,MF} at 4 kHz	4 A	17.5 A	38 A
Nominal current I _{N,MF} at 8 kHz	3.3 A	15.2 A	30.4 A
Max. permitted motor cable length with output choke	100 m		
Max. surrounding temperature $\vartheta_{amb,max}$	40 °C		
Protection class	IP00		
Winding losses	11 W	29 W	61 W
Iron losses	25 W	16 W	33 W
Connection	Screw terminal		
Max. conductor cross-section	10 mm ²		
UL Recognized Component (CAN; USA)	Yes		
Test symbols	cURus, CE		

Tab. 59: TEP specification

Dimensions

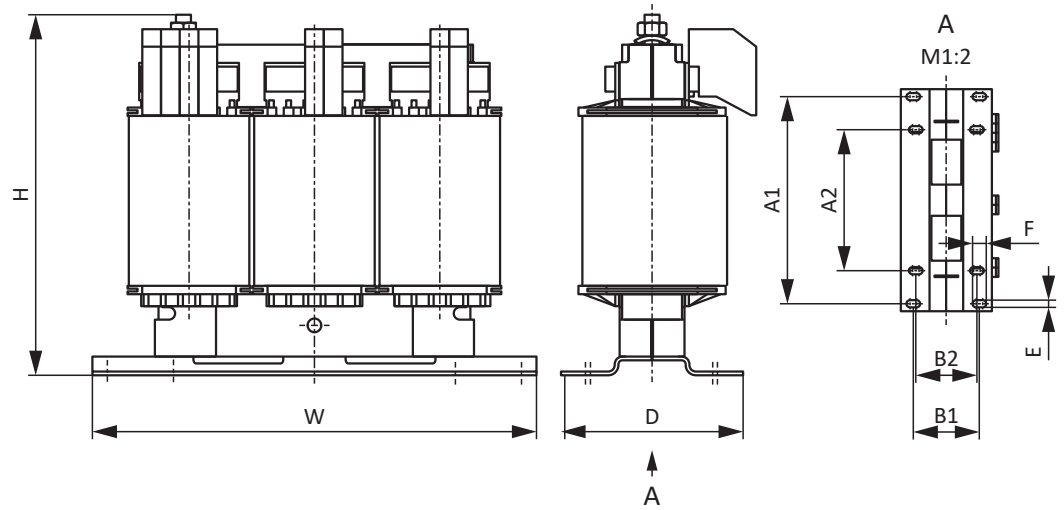

Fig. 14: TEP dimensional drawing

Dimension	TEP3720-0ES41	TEP3820-0CS41	TEP4020-0RS41
Height H [mm]	Max. 153	Max. 153	Max. 180
Width W [mm]	178	178	219
Depth D [mm]	73	88	119
Vertical distance – Fastening holes A1 [mm]	166	166	201
Vertical distance – Fastening holes A2 [mm]	113	113	136
Horizontal distance – Fastening holes B1 [mm]	53	68	89
Horizontal distance – Fastening holes B2 [mm]	49	64	76
Drill holes – Depth E [mm]	5.8	5.8	7
Drill holes – Width F [mm]	11	11	13
Screw connection – M	M5	M5	M6
Weight without packaging [g]	2900	5900	8800

Tab. 60: TEP dimensions and weight

3.4.7 Encoder battery module

Absolute Encoder Support AES



ID No. 55452

Battery module for buffering the supply voltage when using the EnDat 2.2 digital inductive encoder with battery-buffered multi-turn stage, for example EBI1135 or EBI135.

A battery is included.

Information

Note that a 15-pin extension cable between the socket and the AES may be necessary for the connection to the drive controller due to limited space.

- A commercially available shielded extension cable with a 15-pin D-sub connector and a length of ≤ 1 m can be used between the socket and the AES.

AES replacement battery



ID No. 55453

Replacement battery for AES battery module.

3.4.8 HTL-to-TTL adapter

HT6 HTL-to-TTL adapter



ID No. 56665

Adapters for SC6 and SI6 series drive controllers for level conversion from HTL signals to TTL signals.

It is used to connect an HTL differential incremental encoder to terminal X4 of the drive controller.

3.5 Further information

3.5.1 Directives and standards

The following European directives and standards are relevant to the drive controllers:

- Machinery Directive 2006/42/EC
- Low Voltage Directive 2014/35/EU
- EMC Directive 2014/30/EU
- EN ISO 13849-1:2015
- EN ISO 13849-2:2012
- EN 61800-3:2018
- EN 61800-5-1:2017
- EN 61800-5-2:2017

3.5.2 Symbols, marks and test symbols



Grounding symbol

Grounding symbol in accordance with IEC 60417, symbol 5019.



RoHS lead-free mark

Marking in accordance with RoHS directive 2011-65-EU.



CE mark

Manufacturer's self declaration: The product meets the requirements of EU directives.



UKCA test symbol

Manufacturer's self declaration: The product meets the requirements of UK directives.



UL test symbol

This product is listed by UL for the United States and Canada. Representative samples of this product have been evaluated by UL and meet the requirements of applicable standards.



UL recognized component mark

This component or material is recognized by UL. Representative samples of this product have been evaluated by UL and meet applicable requirements.

3.5.3 Additional documentation

Additional documentation related to the product can be found at

<http://www.stoeber.de/en/downloads/>

Enter the ID of the documentation in the Search field.

Documentation	ID
Manual for SI6 drive controllers	442728

4 SD6 drive controllers

Table of contents

4.1	Overview	92
4.1.1	Features.....	93
4.1.2	Software components	95
4.1.3	Application training.....	95
4.2	Technical data	96
4.2.1	Type designation	96
4.2.2	Sizes.....	96
4.2.3	General technical data	97
4.2.4	Electrical data.....	98
4.2.5	Cycle times	104
4.2.6	Derating.....	105
4.2.7	Dimensions.....	107
4.2.8	Weight.....	109
4.2.9	Minimum clearances	110
4.3	Drive controller/motor combinations.....	112
4.4	Accessories	114
4.4.1	Safety technology.....	114
4.4.2	Communication	115
4.4.3	Terminal module	116
4.4.4	DC link connection.....	118
4.4.5	Braking resistor	119
4.4.6	Choke	125
4.4.7	EMC shroud	129
4.4.8	Encoder adapter box	129
4.4.9	Encoder battery module	130
4.4.10	Removable data storage	130
4.5	Further information	131
4.5.1	Directives and standards.....	131
4.5.2	Symbols, marks and test symbols	131
4.5.3	Additional documentation	131



4 Drive controllers

SD6

4.1 Overview

High performance and flexibility

Features

- Nominal output current up to 85 A
- 250% overload capacity
- Control of linear and rotary synchronous servo motors and asynchronous motors
- Multi-functional encoder interfaces
- Automatic motor parameterization from the electronic motor nameplate
- Isochronic system bus (IGB motion bus) for parameterization and multi-axis applications
- Communication over CANopen, EtherCAT or PROFINET
- Safe Torque Off (STO) in the standard version, expanded safety technology (SS1, SS2, SLS, etc.) as an option
- Digital and analog inputs and outputs as an option
- Brake chopper, brake control and line filter
- Energy supply through direct power supply
- Flexible DC link connection for multi-axis applications
- Convenient operating unit consisting of graphical display and keys
- Paramodul removable data storage for quick commissioning and service

4.1.1 Features

STOBER drive controllers of the SD6 series offer maximum precision and productivity for automation technology and mechanical engineering despite ever more complex functions. Highly dynamic drives ensure the shortest recovery times from fast changes in set value and load jumps. There is also an option of connecting the drive controllers in a DC link for multi-axis applications, which improves the energy footprint of the entire system. The SD6 drive controller is available in four sizes with a nominal output current of up to 85 A.

For STOBER synchronous servo motors, we recommended operation with EnDat 2.1/2.2 digital encoders. These encoder systems can deliver the highest control quality. It is possible to perform motor parameterization automatically from the electronic motor nameplate.



SD6 drive controller

32-bit Dual-Core

The control unit of the SD6 with a 32-bit dual-core processor opens up new dimensions in terms of precise movements and dynamics. The position, speed and torque control of the servo axes are calculated at a cycle time of $62.5 \mu\text{s}$ (16 kHz). This ensures the shortest recovery times from fast changes in set values and load jumps.

Fully electronic STO as a standard feature

There is already a wear-free, fully electronic interface for the Safe Torque Off (STO) safety function available in the standard series version. The solution is a technical innovation that works without any system tests disrupting operation. In practical terms, this means an impressive increase in the availability of machines and systems. Time-consuming planning and documentation of tests are also eliminated. In multi-axis applications with SD6 drive controllers, the STO safety function can simply be looped through. The safety-relevant functions were developed together with Pilz GmbH & Co. KG.



Expanded safety option

In addition to the safe stop functions Safe Stop 1 (SS1) and Safe Stop 2 (SS2), additional safety functions such as Safely-Limited Speed (SLS), Safe Brake Control (SBC), Safe Brake Test (SBT), Safe Direction (SDI) and Safely-Limited Increment (SLI) are also available.

Certified safety

TÜV certification makes it possible to use SD6 drive controllers even in applications with challenging safety requirements:

- SIL 3, HFT 1 in accordance with EN 61800-5-2
- PL e, category 4 in accordance with DIN EN ISO 13849

Quick DC-Link

All the product types of the SD6 drive controller have the option of a DC link connection. This technology makes it possible for the regenerative production of energy from one drive to be used as motor energy by another drive. The Quick DC-Link rear structure element has been developed to set up a reliable and efficient rail connection to the DC link connection. This optionally available accessory connects the DC links of the individual drive controllers by means of copper rails that can carry a load of up to 200 A. The rails can be attached without any tools using quick fastening clamps.

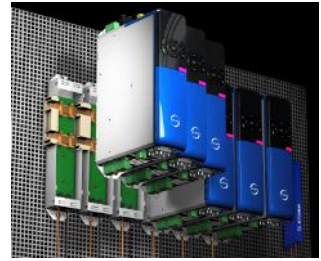

Paramodul removable data storage

Removable data storage with integrated microSD card is available for fast series commissioning by copying and for easy service when replacing devices. It represents the ideal medium for saving additional project data and documentation and can be used for direct editing on a PC.



Integrated bus (IGB)

SD6 drive controllers have two interfaces for the integrated bus in the standard version. The integrated bus is used for easy configuration over Ethernet and isochronic data exchange for the following functions:

- Multi-axis synchronization between the drive controllers (IGB motion bus)
- Direct connection for remote maintenance of individual and multiple drive controllers
- Direct connection between one or more drive controllers and a PC

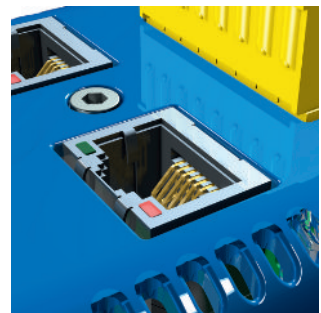

Interface for the Integrated Bus

IGB motion bus

The IGB motion bus allows for cyclic, isochronic data exchange between multiple SD6 drive controllers integrated into the IGB network. In addition to transferring guide values for master/slave operation, it is possible to exchange any other data as well.

STOBER remote maintenance concept

STOBER remote maintenance enables commissioning software to be used to perform all processes and sequences just like an on-site service visit. The concept guides users through a controlled and protected procedure. It ensures that the person responsible for the machine is there on site to pay attention to special situations and personal safety. On the other end, the remote maintenance specialist has the assurance of communicating with a responsible employee on site who is monitoring the situation on the machine.

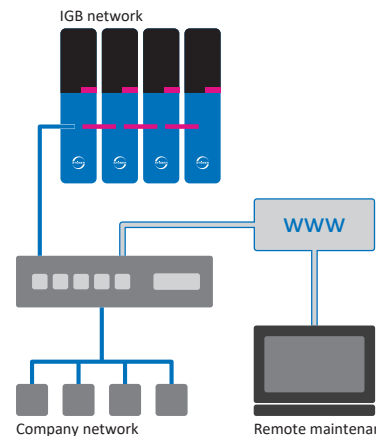

Remote maintenance enables all processes and sequences to be performed just like an on-site service visit.

Brake management

The SD6 drive controller can activate a 24 V_{DC} brake using an integrated brake control. Brake management provides two functions for the brake system:

- Cyclic brake test
- Bed in brake

4.1.2 Software components

Project configuration and commissioning

The 6th generation of DriveControlSuite project configuration and commissioning software has all the functions for the efficient use of drive controllers in single-axis and multi-axis applications. The program guides you step by step through the complete project configuration and parameterization process using wizards.

Open communication

Device communication is possible using EtherCAT, CANopen or PROFINET.

Applications

A drive-based application is recommended for the decentralized motion control of sophisticated machines.

The drive-based application package from STOBBER is the right choice wherever universal and flexible solutions are needed. The Drive Based Synchronous application provides drive-based motion control for synchronous operation, positioning, velocity and torque/force with the PLCopen Motion Control command set. These standard commands have been combined into operating modes for different application cases and supplemented with additional functions such as motion block linking or cams. For the command operating mode, all properties of the movements are specified directly by the controller. The properties of the movements in the drive are predefined in the motion block operating mode so that only a start signal is necessary to perform the movement. Linking can be used to define complete motion sequences.

In addition, the CiA 402 application is also available, which includes both the controller-based and drive-based operating modes (csp, csv, cst, ip, pp, pv, pt).

4.1.3 Application training

STOBBER offers a multi-level training program that is essentially focused on the drive controller.

G6 Basic

Training content: System overview, installation and commissioning of the drive controller. Use of option modules. Parameterization, commissioning and diagnostics using the commissioning software. Remote maintenance. Basics of controller optimization. Configuration of the drive train. Integrated software functions. Software applications. Connection to a higher-level controller. Basics of safety technology. Practical exercises on training topics.

Software used: DriveControlSuite.

G6 Customized

Training content: Special knowledge for regulating, control and safety technology. Electronic cam disk. Practical exercises on training topics.

4.2 Technical data

Technical data for the drive controller can be found in the following chapters.

4.2.1 Type designation

SD	6	A	0	6	T	E	X
----	---	---	---	---	---	---	---

Tab. 1: Example code for type designation

Code	Designation	Design
SD	Series	
6	Generation	Generation 6
A, B	Version	
0 – 3	Size	
6 (0 – 9)	Power output stage	Power output stage within the size
T	Safety module	ST6: STO via terminals
E		SE6: Expanded safety functionality via terminals
N	Communication module	Empty
E		EC6: EtherCAT
C		CA6: CANopen
P		PN6: PROFINET
N	Terminal module	Empty
X		XI6: Extended
R		RI6: Resolver
I		IO6: Standard

Tab. 2: Meaning of the example code

4.2.2 Sizes

Type	Size
SD6A02	Size 0
SD6A04	Size 0
SD6A06	Size 0
SD6A14	Size 1
SD6A16	Size 1
SD6A24	Size 2
SD6A26	Size 2
SD6A34	Size 3
SD6A36	Size 3
SD6A38	Size 3

Tab. 3: Available SD6 types and sizes



SD6 in sizes 0, 1, 2 and 3

4.2.3 General technical data

The following information applies to all device types.

Device features	
Protection class of the device	IP20
Protection class of the installation space	At least IP54
Protection class	Protection class I in accordance with EN 61140
Radio interference suppression	Integrated line filter in accordance with EN 61800-3, interference emission class C3
Overvoltage category	III in accordance with EN 61800-5-1
Test symbols	CE, cULus, RoHS

Tab. 4: Device features

Transport and storage conditions	
Storage/transport temperature	-20 °C to +70 °C Maximum change: 20 K/h
Relative humidity	Maximum relative humidity 85%, non-condensing
Vibration (transport) in accordance with EN 60068-2-6	5 Hz ≤ f ≤ 9 Hz: 3.5 mm 9 Hz ≤ f ≤ 200 Hz: 10 m/s ² 200 Hz ≤ f ≤ 500 Hz: 15 m/s ²
Fall height for freefall ¹ Weight < 100 kg in accordance with EN 61800-2 (or IEC 60721-3-2, class 2M1)	0.25 m

Tab. 5: Transport and storage conditions

Operating conditions	
Surrounding temperature during operation	0 °C to 45 °C with nominal data 45 °C to 55 °C with derating -2.5% / K
Relative humidity	Maximum relative humidity 85%, non-condensing
Installation altitude	0 m to 1000 m above sea level without restrictions 1000 m to 2000 m above sea level with -1.5%/100 m derating
Pollution degree	Pollution degree 2 in accordance with EN 50178
Ventilation	Installed fan
Vibration (operation) in accordance with EN 60068-2-6	5 Hz ≤ f ≤ 9 Hz: 0.35 mm 9 Hz ≤ f ≤ 200 Hz: 1 m/s ²

Tab. 6: Operating conditions

Discharge times	
Self-discharge of DC link	6 min

Tab. 7: Discharge times of the DC link circuit

¹Only valid for components in original packaging

4.2.4 Electrical data

The electrical data of the available SD6 sizes as well as the properties of the brake chopper can be found in the following chapters.

Information

For the time span between energizing two devices, note that:

- Direct, repeat activation of the supply voltage is possible for cyclical power-on/power-off operation.

Information

The STO safety function is available for safe stopping as an alternative to continuous, cyclical power-on/power-off operation.

An explanation of the symbols used for formulas can be found in Chapter [\[▶ 9.1\]](#).

4.2.4.1 Control unit

Electrical data	All types
U_{1CU}	24 V _{DC} , +20%/–15%
I_{1maxCU}	1.5 A

Tab. 8: Control unit electrical data

4.2.4.2 Power unit: Size 0

Electrical data	SD6A02	SD6A04	SD6A06
U_{1PU}	$1 \times 230 V_{AC}$ +20% / -40%, 50/60 Hz	$3 \times 400 V_{AC}$ +32% / -50%, 50/60 Hz; $3 \times 480 V_{AC}$ +10% / -58%, 50/60 Hz	
f_{2PU}	0 – 700 Hz		
U_{2PU}	0 – max. U_{1PU}		
$U_{2PU,ZK}$	$\sqrt{2} \times U_{1PU}$		
C_{PU}	340 μF	135 μF	135 μF
$C_{N,PU}$	1620 μF	540 μF	540 μF

Tab. 9: SD6 electrical data, size 0

Nominal currents up to +45 °C (in the control cabinet)

Electrical data	SD6A02	SD6A04	SD6A06
$f_{PWM,PU}$	4 kHz		
$I_{1N,PU}$	8.3 A	2.8 A	5.4 A
$I_{2N,PU}$	4 A	2.3 A	4.5 A
I_{2maxPU}	180% for 5 s; 150% for 30 s		

Tab. 10: SD6 electrical data, size 0, for 4 kHz clock frequency

Electrical data	SD6A02	SD6A04	SD6A06
$f_{PWM,PU}$	8 kHz		
$I_{1N,PU}$	6 A	2.2 A	4 A
$I_{2N,PU}$	3 A	1.7 A	3.4 A
I_{2maxPU}	250% for 2 s; 200% for 5 s		

Tab. 11: SD6 electrical data, size 0, for 8 kHz clock frequency

Electrical data	SD6A02	SD6A04	SD6A06
U_{onCH}	400 – 420 V_{DC}	780 – 800 V_{DC}	
U_{offCH}	360 – 380 V_{DC}	740 – 760 V_{DC}	
R_{2minRB}	100 Ω		
P_{maxRB}	1.8 kW	6.4 kW	
P_{effRB}	1.0 kW	2.9 kW	

Tab. 12: Brake chopper electrical data, size 0

4.2.4.3 Power unit: Size 1

Electrical data	SD6A14	SD6A16
U_{1PU}	3 × 400 V _{AC} , +32% / -50%, 50/60 Hz; 3 × 480 V _{AC} , +10% / -58%, 50/60 Hz	
f_{2PU}	0 – 700 Hz	
U_{2PU}	0 – max. U_{1PU}	
$U_{2PU,ZK}$	$\sqrt{2} \times U_{1PU}$	
C_{PU}	470 μF	560 μF
$C_{N,PU}$	1400 μF	1400 μF

Tab. 13: SD6 electrical data, size 1

Nominal currents up to +45 °C (in the control cabinet)

Electrical data	SD6A14	SD6A16
$f_{PWM,PU}$	4 kHz	
$I_{1N,PU}$	12 A	19.2 A
$I_{2N,PU}$	10 A	16 A
I_{2maxPU}	180% for 5 s; 150% for 30 s	

Tab. 14: SD6 electrical data, size 1, for 4 kHz clock frequency

Electrical data	SD6A14	SD6A16
$f_{PWM,PU}$	8 kHz	
$I_{1N,PU}$	9.3 A	15.8 A
$I_{2N,PU}$	6 A	10 A
I_{2maxPU}	250% for 2 s; 200% for 5 s	

Tab. 15: SD6 electrical data, size 1, for 8 kHz clock frequency

Electrical data	SD6A14	SD6A16
U_{onCH}	780 – 800 V _{DC}	
U_{offCH}	740 – 760 V _{DC}	
R_{2minRB}	47 Ω	
P_{maxRB}	13.6 kW	
P_{effRB}	6.2 kW	

Tab. 16: Brake chopper electrical data, size 1

4.2.4.4 Power unit: Size 2

Electrical data	SD6A24	SD6A26
U_{1PU}	3 × 400 V _{AC} , +32% / -50%, 50/60 Hz; 3 × 480 V _{AC} , +10% / -58%, 50/60 Hz	
f_{2PU}	0 – 700 Hz	
U_{2PU}	0 – max. U_{1PU}	
$U_{2PU,ZK}$	$\sqrt{2} \times U_{1PU}$	
C_{PU}	680 μF	1000 μF
$C_{N,PU}$	1400 μF	1400 μF

Tab. 17: SD6 electrical data, size 2

Nominal currents up to +45 °C (in the control cabinet)

Electrical data	SD6A24	SD6A26
$f_{PWM,PU}$	4 kHz	
$I_{1N,PU}$	26.4 A	38.4 A
$I_{2N,PU}$	22 A	32 A
I_{2maxPU}	180% for 5 s; 150% for 30 s	

Tab. 18: SD6 electrical data, size 2, for 4 kHz clock frequency

Electrical data	SD6A24	SD6A26
$f_{PWM,PU}$	8 kHz	
$I_{1N,PU}$	24.5 A	32.6 A
$I_{2N,PU}$	14 A	20 A
I_{2maxPU}	250% for 2 s; 200% for 5 s	

Tab. 19: SD6 electrical data, size 2, for 8 kHz clock frequency

Electrical data	SD6A24	SD6A26
U_{onCH}	780 – 800 V _{DC}	
U_{offCH}	740 – 760 V _{DC}	
R_{2minRB}	22 Ω	
P_{maxRB}	29.1 kW	
P_{effRB}	13.2 kW	

Tab. 20: Brake chopper electrical data, size 2

4.2.4.5 Power unit: Size 3

Electrical data	SD6A34	SD6A36	SD6A38
U_{1PU}	3 × 400 V _{AC} , +32% / -50%, 50/60 Hz; 3 × 480 V _{AC} , +10% / -58%, 50/60 Hz		
f_{2PU}	0 – 700 Hz		
U_{2PU}	0 – max. U_{1PU}		
$U_{2PU,ZK}$	$\sqrt{2} \times U_{1PU}$		
C_{PU}	430 μF	900 μF	900 μF
$C_{N,PU}$	5100 μF	5100 μF	5100 μF

Tab. 21: SD6 electrical data, size 3

Nominal currents up to +45 °C (in the control cabinet)

Electrical data	SD6A34	SD6A36	SD6A38
$f_{PWM,PU}$	4 kHz		
$I_{1N,PU}$	45.3 A	76 A	76 A
$I_{2N,PU}$	44 A	70 A	85 A ²
I_{2maxPU}	180% for 5 s; 150% for 30 s		

Tab. 22: SD6 electrical data, size 3, for 4 kHz clock frequency

Electrical data	SD6A34	SD6A36	SD6A38
$f_{PWM,PU}$	8 kHz		
$I_{1N,PU}$	37 A	62 A	76 A
$I_{2N,PU}$	30 A	50 A	60 A
I_{2maxPU}	250% for 2 s; 200% for 5 s		

Tab. 23: SD6 electrical data, size 3, for 8 kHz clock frequency

Electrical data	SD6A34	SD6A36	SD6A38
U_{onCH}	780 – 800 V _{DC}		
U_{offCH}	740 – 760 V _{DC}		
R_{intRB}	30 Ω (PTC resistance; 100 W; max. 1 kW for 1 s; τ = 40 s)		
R_{2minRB}	15 Ω		
P_{maxRB}	42 kW		
P_{effRB}	19.4 kW		

Tab. 24: Brake chopper electrical data, size 3

4.2.4.6 DC link connection

The charging capacity of the drive controllers can be increased by a DC link connection only if the power grid supply is connected to all drive controllers simultaneously.

4.2.4.7 Power loss data in accordance with EN 61800-9-2

Type	Nominal current $I_{2N,PU}$	Apparent power	Absolute losses $P_{V,CU}^3$	Operating points ⁴								IE class ⁵	Comparison ⁶
				(0/25)	(0/50)	(0/100)	(50/25)	(50/50)	(50/100)	(90/50)	(90/100)		
				Relative losses									
				Relative losses									
	[A]	[kVA]	[W]	[%]									
SD6A02	4	0.9	10	5.01	5.07	5.68	5.20	5.37	6.30	5.88	7.43	IE2	
SD6A04	2.3	1.6	10	2.98	3.13	3.49	3.02	3.22	3.71	3.36	4.09	IE2	
SD6A06	4.5	3.1	12	1.71	1.86	2.24	1.75	1.97	2.51	2.16	3.04	IE2	
SD6A14	10	6.9	12	1.38	1.54	1.93	1.43	1.64	2.17	1.80	2.57	IE2	
SD6A16	16	11.1	12	0.95	1.12	1.66	0.99	1.23	1.98	1.41	2.52	IE2	
SD6A24	22	15.2	15	0.80	0.97	1.49	0.84	1.06	1.75	1.21	2.19	IE2	
SD6A26	32	22.2	15	0.70	0.87	1.40	0.74	0.97	1.67	1.11	2.10	IE2	
SD6A34	44	30.5	35	0.61	0.76	1.21	0.68	0.90	1.53	1.06	1.96	IE2	
SD6A36	70	48.5	35	0.53	0.69	1.18	0.59	0.82	1.49	0.97	1.89	IE2	
SD6A38	85	58.9	35	0.47	0.64	1.18	0.54	0.78	1.50	0.94	1.94	IE2	
				Absolute losses									
				Absolute losses									
	[A]	[kVA]	[W]	[W]									[%]
SD6A02	4	0.9	10	45.1	45.6	51.1	46.8	48.3	56.7	52.9	66.9	IE2	51.8
SD6A04	2.3	1.6	10	47.7	50.1	55.8	48.3	51.5	59.3	53.8	65.4	IE2	40.2
SD6A06	4.5	3.1	12	52.9	57.6	69.3	54.4	61.0	77.9	67.1	94.1	IE2	39.6
SD6A14	10	6.9	12	95.3	106.1	133.3	98.6	113.2	149.9	123.9	177.0	IE2	37.1
SD6A16	16	11.1	12	104.9	124.0	184.6	110.3	136.6	219.8	156.0	279.8	IE2	35.8
SD6A24	22	15.2	15	121.5	146.9	226.1	128.1	161.6	266.0	183.7	332.7	IE2	32.9
SD6A26	32	22.2	15	154.7	192.8	311.3	164.7	214.9	370.5	246.9	465.9	IE2	38.6
SD6A34	44	30.5	35	187.5	232.2	368.7	207.7	273.9	466.8	323.0	597.8	IE2	32.1
SD6A36	70	48.5	35	256.6	332.3	570.8	287.9	397.0	721.5	471.0	915.9	IE2	33.9
SD6A38	85	58.9	35	277.8	376.9	692.3	317.4	459.0	886.1	554.6	1143.1	IE2	35.3

Tab. 25: Power loss data of the SD6 drive controller in accordance with EN 61800-9-2

General conditions

The loss data applies to drive controllers without any accessories.

The power loss calculation is based on a three-phase supply voltage with 400 V_{AC}/50 Hz.

The calculated data includes a supplement of 10% in accordance with EN 61800-9-2.

The power loss specifications refer to a clock frequency of 4 kHz.

The absolute losses for a power unit that is switched off refer to the 24 V_{DC} power supply of the control electronics.

³ Absolute losses for a power unit that is switched off

⁴ Operating points for relative motor stator frequency in % and relative torque current in %

⁵ IE class in accordance with EN 61800-9-2

⁶ Comparison of the losses for the reference related to IE2 in the nominal point (90, 100)

4.2.4.8 Power loss data of accessories

If you intend to order the drive controller with accessory parts, losses increase as follows:

Type	Absolute losses P_v [W]
SE6 safety module	< 4
ST6 safety module	1
IO6 terminal module	< 2
XI6 terminal module	< 5
RI6 terminal module	< 5
CA6 communication module	1
EC6 communication module	< 2
PN6 communication module	< 4

Tab. 26: Absolute losses of the accessories

Information

Note the absolute power loss of the encoder (usually < 3 W) and of the brake when designing as well.

Loss specifications for other optional accessories can be found in the technical data of the respective accessory part.

4.2.5 Cycle times

Possible cycle times can be found in the following table.

Type	Cycle times	Relevant parameters
Application	1 ms, 2 ms, 4 ms, 8 ms	Adjustable in A150
EtherCAT fieldbus, cyclical communication	1 ms, 2 ms, 4 ms, 8 ms	Adjustable in A150
PROFINET RT fieldbus, cyclical communication	1 ms, 2 ms, 4 ms, 8 ms	Adjustable in A150
Inputs and outputs	1 ms, 2 ms, 4 ms, 8 ms	Adjustable in A150 ⁷
Motion core (movement calculation)	250 μ s	—
Control cascade	62.5 μ s, 125 μ s	Depending on B24

Tab. 27: Cycle times

4.2.6 Derating

When dimensioning the drive controller, observe the derating of the nominal output current as a function of the clock frequency, surrounding temperature and installation altitude. There is no restriction for a surrounding temperature from 0 °C to 45 °C and an installation altitude of 0 m to 1000 m. The details given below apply to values outside these ranges.

4.2.6.1 Effect of the clock frequency

Changing the clock frequency f_{PWM} affects the amount of noise produced by the drive, among other things. However, increasing the clock frequency results in increased losses. During project configuration, define the highest clock frequency and use it to determine the nominal output current $I_{2N,PU}$ for dimensioning the drive controller.

Type	$I_{2N,PU}$ 4 kHz	$I_{2N,PU}$ 8 kHz	$I_{2N,PU}$ 16 kHz
SD6A02	4 A	3 A	2 A
SD6A04	2.3 A	1.7 A	1.1 A
SD6A06	4.5 A	3.4 A	2.3 A
SD6A14	10 A	6 A	4 A
SD6A16	16 A	10 A	5.7 A
SD6A24	22 A	14 A	8.1 A
SD6A26	32 A	20 A	12 A
SD6A34	44 A	30 A	18 A
SD6A36	70 A	50 A	31 A
SD6A38	85 A ⁸	60 A	37.8 A

Tab. 28: Nominal output current $I_{2N,PU}$ dependent on the clock frequency

4.2.6.2 Effect of the installation altitude

Derating as a function of the installation altitude is determined as follows:

- 0 m to 1000 m: No restriction ($D_{IA} = 100\%$)
- 1000 m to 2000 m: Derating $-1.5\%/100$ m

Example

The drive controller needs to be installed at an altitude of 1500 m above sea level.

The derating factor D_{IA} is calculated as follows:

$$D_{IA} = 100\% - 5 \times 1.5\% = 92.5\%$$

4.2.6.3 Effect of the surrounding temperature

Derating as a function of the surrounding temperature is determined as follows:

- 0 °C to 45 °C: No restrictions ($D_T = 100\%$)
- 45 °C to 55 °C: Derating $-2.5\%/K$

Example

The drive controller needs to be operated at 50 °C.

The derating factor D_T is calculated as follows

$$D_T = 100\% - 5 \times 2.5\% = 87.5\%$$

⁸ Specification applies to the default value of the field weakening voltage limit: B92 = 80%.

4.2.6.4 Calculating the derating

Follow these steps for the calculation:

1. Determine the highest clock frequency (f_{PWM}) that will be used during operation and use it to determine the nominal current $I_{2\text{N,PU}}$.
2. Determine the derating factors for installation altitude and surrounding temperature.
3. Calculate the reduced nominal current $I_{2\text{N,PU(red)}}$ in accordance with the following formula:

$$I_{2\text{N,PU(red)}} = I_{2\text{N,PU}} \times D_{\text{T}} \times D_{\text{IA}}$$

Example

A drive controller of type SD6A06 needs to be operated at a clock frequency of 8 kHz at an altitude of 1500 m above sea level and a surrounding temperature of 50 °C.

The nominal current of the SD6A06 at 8 kHz is 3.4 A. The derating factor D_{T} is calculated as follows:

$$D_{\text{T}} = 100\% - 5 \times 2.5\% = 87.5\%$$

The derating factor D_{IA} is calculated as follows:

$$D_{\text{IA}} = 100\% - 5 \times 1.5\% = 92.5\%$$

The output current of importance for the project configuration is:

$$I_{2\text{N,PU(red)}} = 3.4 \text{ A} \times 0.875 \times 0.925 = 2.75 \text{ A}$$

4.2.7 Dimensions

The dimensions of the available SD6 sizes can be found in the following chapters.

4.2.7.1 Dimensions: sizes 0 to 2

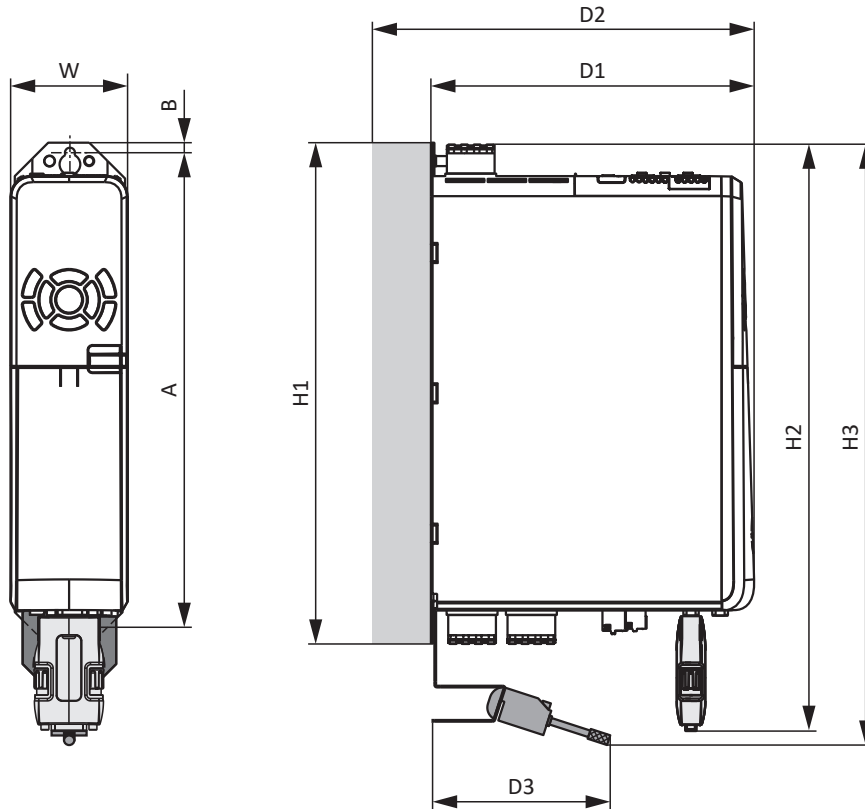

Fig. 1: SD6 dimensional drawing, sizes 0 to 2

Dimension			Size 0	Size 1	Size 2
Drive controller	Width	W	70	70	105
	Depth	D1	194	284	
	Depth incl. RB 5000 braking resistor	D2	212	302	
	Depth incl. Quick DC-Link	D2	229	319	
	Height incl. fastening clips	H1		300	
	Height incl. AES	H2		367	
	Height incl. EMC shroud	H3		approx. 376	
EMC shroud incl. shield connection terminal	Depth	D3		approx. 111	
Fastening holes	Vertical distance	A		283+2	
	Vertical distance to the upper edge	B		6	

Tab. 29: SD6 dimensions, sizes 0 to 2 [mm]

4.2.7.2 Dimensions: size 3

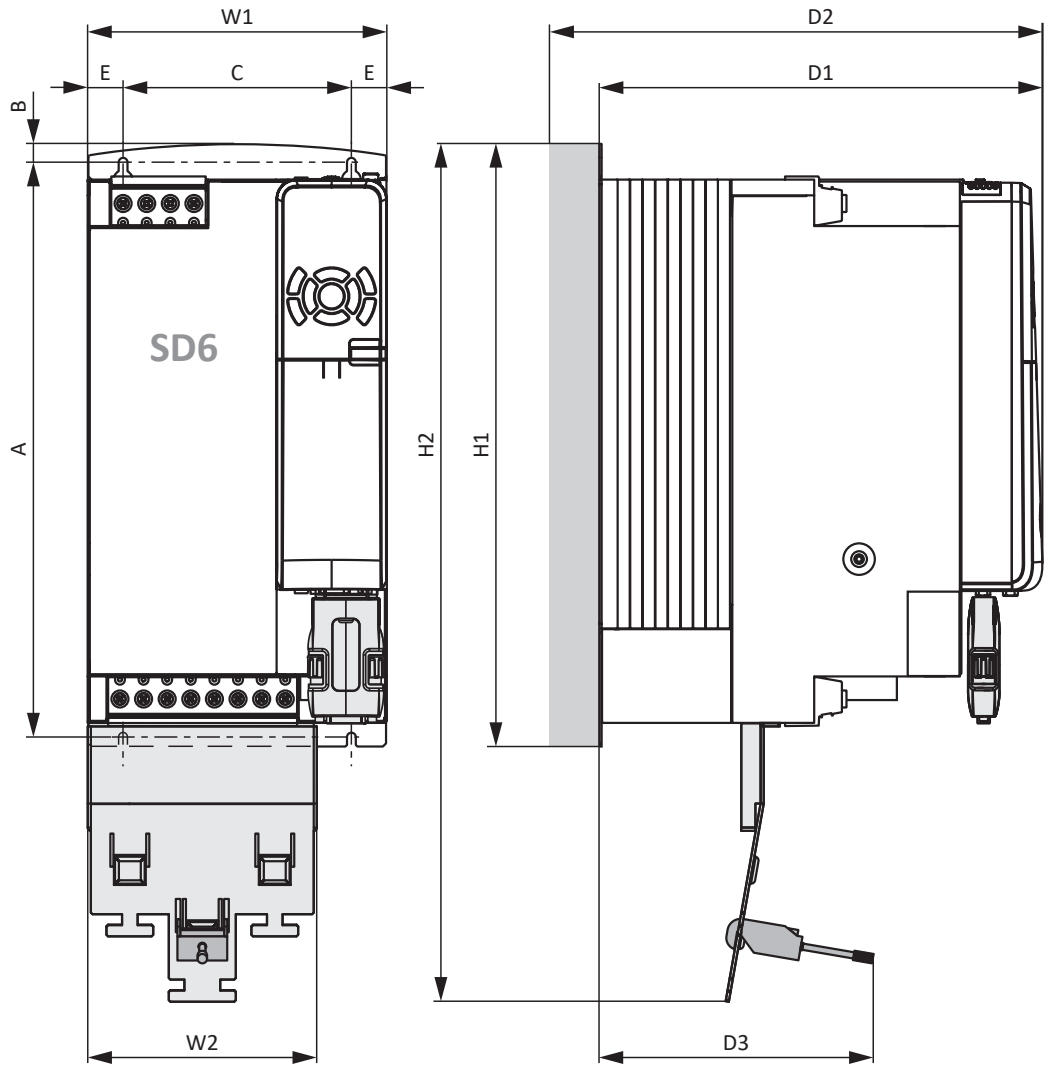

Fig. 2: SD6 dimensional drawing, size 3

Dimension			Size 3
Drive controller	Width	W1	190
	Depth	D1	305
	Depth incl. Quick DC-Link	D2	340
	Height incl. fastening clips	H1	382.5
	Height incl. EMC shroud	H2	540
EMC shroud incl. shield connection terminal	Width	W2	147
	Depth	D3	approx. 174
Fastening holes	Vertical distance	A	365+2
	Vertical distance to the upper edge	B	11.5
	Horizontal distance between the fastening holes of the drive controller	C	150+0.2/-0.2
	Horizontal distance to the side edge of the drive controller	E	20

Tab. 30: SD6 dimensions, size 3 [mm]

4.2.8 Weight

Size	Weight without packaging [g]	Weight with packaging [g]
Size 0	2530	3520
Size 1	3700	5470
Size 2	5050	6490
Size 3	13300	14800

Tab. 31: SD6 weight [g]

If you intend to order the drive controller with accessory parts, the weight increases as follows.

Accessories	Weight without packaging [g]
Communication module	50
Terminal module	135
Safety module	110

Tab. 32: Weight of the accessory part [g]

4.2.9 Minimum clearances

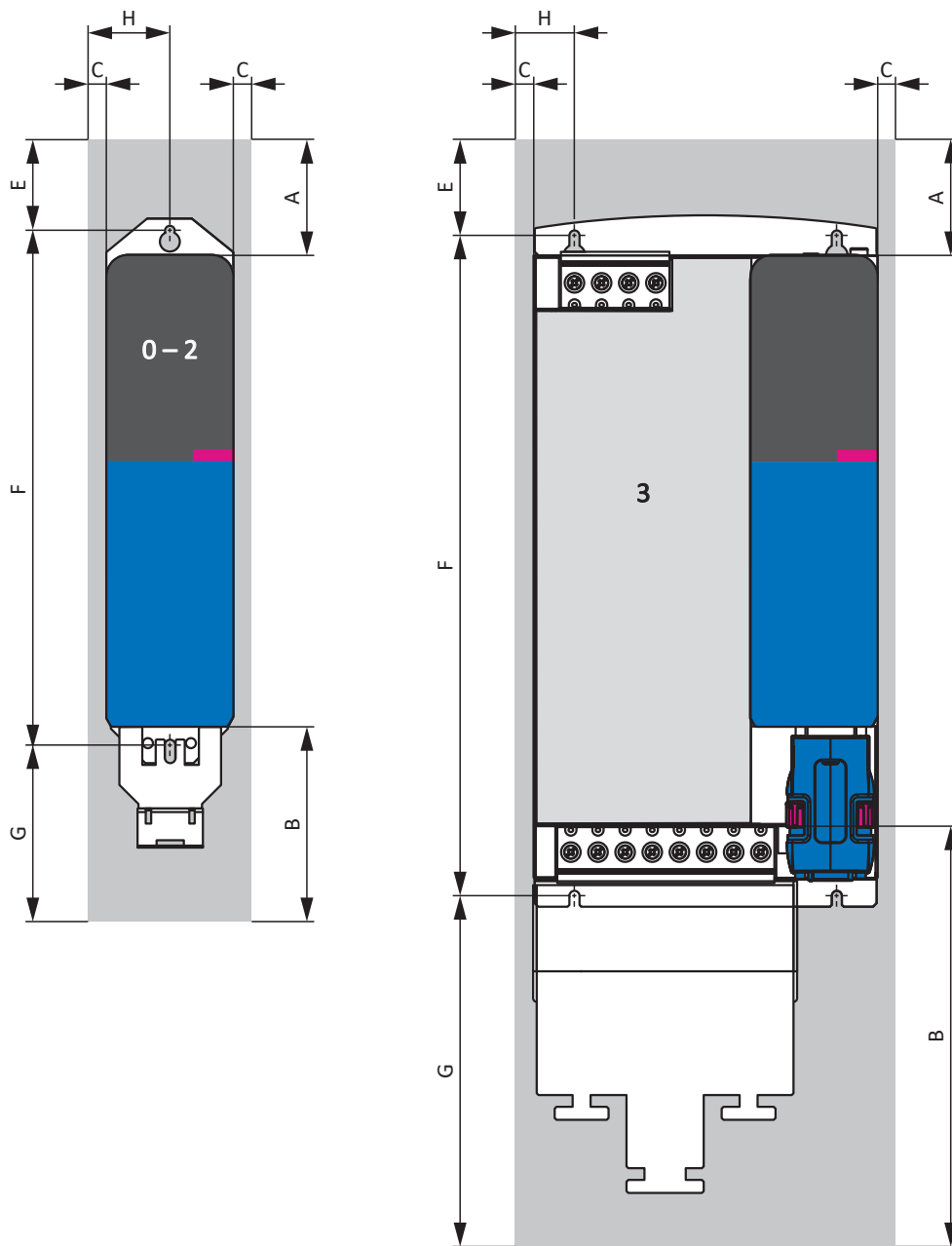

Fig. 3: Minimum clearances

The specified dimensions relate to the outer edges of the drive controller.

Minimum clearance	A (above)	B (below)	C (one the side) ⁹
Size 0 – Size 2	100	100	5
... with EMC shroud	100	120	5
Size 3	100	100	5
... with EMC shroud	100	220	5

Tab. 33: Minimum clearances [mm]

Dimension	E	F	G	H
Size 0, size 1	86	283+2	approx. 89	40
... with EMC shroud	86	283+2	approx. 109	40
Size 2	86	283+2	approx. 89	57.5
... with EMC shroud	86	283+2	approx. 109	57.5
Size 3	89	365+2	approx. 59.5	25
... with EMC shroud	89	365+2	approx. 179.5	25

Tab. 34: Dimensions [mm]

Chokes and filters

Avoid installation below drive controllers or supply modules. For installation in a control cabinet, a distance of approximately 100 mm to other neighboring components is recommended. This distance ensures proper heat dissipation for chokes and filters.

Braking resistors

Avoid installation below drive controllers or supply modules. In order for heated air to flow out unimpeded, a minimum clearance of approximately 200 mm must be maintained in relation to neighboring components or walls and approximately 300 mm must be maintained to components above or ceilings.

⁹ Installation without Quick DC-Link module

4.3 Drive controller/motor combinations

An explanation of the symbols used for formulas can be found in Chapter [\[9.1 \]](#).

EZ synchronous servo motor ($n_N = 2000$ rpm) – SD6

						SD6A02	SD6A04	SD6A06	SD6A14	SD6A16	SD6A24	SD6A26	SD6A34	SD6A36	SD6A38
						$I_{2N,PU}$ [A] ($f_{PWM,PU} = 8$ kHz)									
	K_{EM} [V/1000 rpm]	M_N [Nm]	I_N [A]	M_0 [Nm]	I_0 [A]	3	1.7	3.4	6	10	14	20	30	50	60

IC 410 convection cooling						$I_{2N,PU} / I_0$										
EZ805U	142	43.7	25.9	66.1	37.9										1.3	1.6

IC 416 forced ventilation						$I_{2N,PU} / I_0$										
EZ805B	142	77.2	45.2	94	53.9											1.1

EZ synchronous servo motor ($n_N = 3000$ rpm) – SD6

						SD6A02	SD6A04	SD6A06	SD6A14	SD6A16	SD6A24	SD6A26	SD6A34	SD6A36	SD6A38
						$I_{2N,PU}$ [A] ($f_{PWM,PU} = 8$ kHz)									
	K_{EM} [V/1000 rpm]	M_N [Nm]	I_N [A]	M_0 [Nm]	I_0 [A]	3	1.7	3.4	6	10	14	20	30	50	60

IC 410 convection cooling						$I_{2N,PU} / I_0$										
EZ301U	40	0.93	1.99	0.95	2.02	1.5		1.7								
EZ302U	86	1.59	1.6	1.68	1.67	1.8	1.0	2.0								
EZ303U	109	2.07	1.63	2.19	1.71	1.8	1.0	2.0								
EZ401U	96	2.8	2.74	3	2.88	1.0		1.2								
EZ402U	94	4.7	4.4	5.2	4.8				1.3							
EZ404U	116	6.9	5.8	8.6	6.6					1.5						
EZ501U	97	4.3	3.74	4.7	4				1.5							
EZ502U	121	7.4	5.46	8	5.76				1.0	1.7						
EZ503U	119	9.7	6.9	11.1	7.67					1.3	1.8					
EZ505U	141	13.5	8.8	16	10					1.0	1.4	2.0				
EZ701U	95	7.4	7.2	8.3	8					1.3	1.8					
EZ702U	133	12	8.2	14.4	9.6					1.0	1.5					
EZ703U	122	16.5	11.4	20.8	14						1.0	1.4				
EZ705U	140	21.3	14.2	30.2	19.5							1.0	1.5			
EZ802U	136	22.3	13.9	37.1	22.3								1.3			
EZ803U	131	26.6	17.7	48.2	31.1									1.6	1.9	

IC 416 forced ventilation						$I_{2N,PU} / I_0$										
EZ401B	96	3.4	3.4	3.7	3.6				1.7							
EZ402B	94	5.9	5.5	6.3	5.8				1.0	1.7						
EZ404B	116	10.2	8.2	11.2	8.7					1.1	1.6					
EZ501B	97	5.4	4.7	5.8	5				1.2	2.0						
EZ502B	121	10.3	7.8	11.2	8.16					1.2	1.7					
EZ503B	119	14.4	10.9	15.9	11.8						1.2	1.7				
EZ505B	141	20.2	13.7	23.4	14.7						1.0	1.4				
EZ701B	95	9.7	9.5	10.5	10					1.0	1.4	2.0				
EZ702B	133	16.6	11.8	19.3	12.9						1.1	1.6				
EZ703B	122	24	18.2	28	20							1.0	1.5			
EZ705B	140	33.8	22.9	41.8	26.5								1.1	1.9		
EZ802B	136	34.3	26.5	47.9	28.9									1.0	1.7	
EZ803B	131	49	35.9	66.7	42.3										1.2	1.4

EZ synchronous servo motor ($n_N = 4500$ rpm) – SD6

						SD6A02	SD6A04	SD6A06	SD6A14	SD6A16	SD6A24	SD6A26	SD6A34	SD6A36	SD6A38
						$I_{2N,PU}$ [A] ($f_{PWM,PU} = 8$ kHz)									
	K_{EM} [V/1000 rpm]	M_N [Nm]	I_N [A]	M_0 [Nm]	I_0 [A]	3	1.7	3.4	6	10	14	20	30	50	60

IC 410 convection cooling

						$I_{2N,PU} / I_0$										
EZ505U	103	9.5	8.94	15.3	13.4						1.0	1.5				
EZ703U	99	12.1	11.5	20	17.8							1.1	1.7			
EZ705U	106	16.4	14.8	30	25.2								1.2	2.0		
EZ802U	90	10.5	11.2	34.5	33.3									1.5	1.8	

IC 416 forced ventilation

						$I_{2N,PU} / I_0$										
EZ505B	103	16.4	16.4	22	19.4							1.0	1.5			
EZ703B	99	19.8	20.3	27.2	24.2								1.2			
EZ705B	106	27.7	25.4	39.4	32.8									1.5	1.8	
EZ802B	90	30.6	30.5	47.4	45.1									1.1	1.3	

EZ synchronous servo motor ($n_N = 6000$ rpm) – SD6

						SD6A02	SD6A04	SD6A06	SD6A14	SD6A16	SD6A24	SD6A26	SD6A34	SD6A36	SD6A38
						$I_{2N,PU}$ [A] ($f_{PWM,PU} = 8$ kHz)									
	K_{EM} [V/1000 rpm]	M_N [Nm]	I_N [A]	M_0 [Nm]	I_0 [A]	3	1.7	3.4	6	10	14	20	30	50	60

IC 410 convection cooling

						$I_{2N,PU} / I_0$										
EZ202U	40	0.44	1.07	0.48	1.12		1.5									
EZ203U	40	0.64	1.53	0.73	1.65	1.8	1.0	2.1								
EZ301U	40	0.89	1.93	0.95	2.02	1.5		1.7								
EZ302U	42	1.5	3.18	1.68	3.48				1.7							
EZ303U	55	1.96	3.17	2.25	3.55				1.7							
EZ401U	47	2.3	4.56	2.8	5.36				1.1	1.9						
EZ402U	60	3.5	5.65	4.9	7.43					1.3	1.9					
EZ404U	78	5.8	7.18	8.4	9.78					1.0	1.4	2.0				
EZ501U	68	3.4	4.77	4.4	5.8			1.0	1.7	2.4						
EZ502U	72	5.2	7.35	7.8	9.8					1.0	1.4	2.0				
EZ503U	84	6.2	7.64	10.6	11.6						1.2	1.7				
EZ701U	76	5.2	6.68	7.9	9.38					1.1	1.5					
EZ702U	82	7.2	8.96	14.3	16.5							1.2	1.8			

IC 416 forced ventilation

						$I_{2N,PU} / I_0$										
EZ401B	47	2.9	5.62	3.5	6.83					1.5	2.0					
EZ402B	60	5.1	7.88	6.4	9.34					1.1	1.5					
EZ404B	78	8	9.98	10.5	12						1.2	1.7				
EZ501B	68	4.5	6.7	5.7	7.5					1.3	1.9					
EZ502B	72	8.2	11.4	10.5	13.4						1.0	1.5				
EZ503B	84	10.4	13.5	14.8	15.9							1.3	1.9			
EZ701B	76	7.5	10.6	10.2	12.4						1.1	1.6				
EZ702B	82	12.5	16.7	19.3	22.1								1.4			

4.4 Accessories

You can find information about the available accessories in the following chapters.

4.4.1 Safety technology

Information

The drive controller is delivered with the ST6 safety module in the standard design. If you want a drive controller with advanced safety technology, you must order it together with the drive controller. The safety modules are an integrated part of the drive controllers and must not be modified.

ST6 safety module – STO using terminals

Included in the standard version.



ID No. 56431

Accessory for the use of the Safe Torque Off safety function (STO) in safety-relevant applications (PL e, SIL 3) in accordance with EN ISO 13849-1 and EN 61800-5-2. Connection to a higher-level safety circuit via terminal X12.

SE6 safety module – Expanded safety functionality via terminals



ID No. 56432

Optional accessory for use in safety-related applications up to PL e, SIL 3 in accordance with EN ISO 13849-1 and EN 61800-5-2. In addition to the basic Safe Torque Off (STO) safety function, SE6 provides other safety functions specified in EN 61800-5-2. In addition to the safe stop functions Safe Stop 1 (SS1) and Safe Stop 2 (SS2), these also include Safely-Limited Speed (SLS), Safe Brake Control (SBC), Safe Direction (SDI) and Safely-Limited Increment (SLI). The normative safety functions are supplemented by practical additional functions such as Safe Brake Test (SBT). Connection to the higher-level safety circuit using terminals X14 and X15.

X50 adapter cable (SE6 option)



ID No. 56434

Connection cable for the X50 encoder interface of the SE6 safety module with open cable ends. 1.5 m.

4.4.2 Communication

The SD6 drive controller has two interfaces for IGB communication on the top of the device as standard. The communication module is installed in the shaft at the top and it is used to connect the drive controller to the fieldbus system.

The following communication modules are available:

- EC6 for the EtherCAT connection
- CA6 for the CANopen connection
- PN6 for the PROFINET connection

IGB connecting cable



Cable for connecting the X3A or X3B interface for IGB, CAT5e, magenta.

The following designs are available:

ID No. 56489: 0.4 m.

ID No. 56490: 2 m.

PC connecting cables



ID No. 49857

Cable for connecting the X3A or X3B interface with the PC, CAT5e, blue, 5 m.

USB 2.0 Ethernet adapter



ID No. 49940

Adapter for connecting Ethernet to a USB port.

EC6 communication module

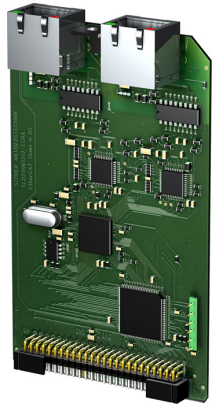

ID No. 138425

Communication module for the EtherCAT connection.

EtherCAT cables



Ethernet patch cable, CAT5e, yellow.

The following designs are available:

ID No. 49313: Length approx. 0.25 m.

ID No. 49314: Length approx. 0.5 m.

CA6 communication module

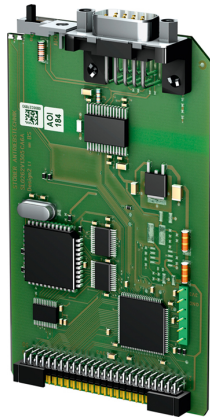

ID No. 138427
 Communication module for the CANopen connection.

PN6 communication module

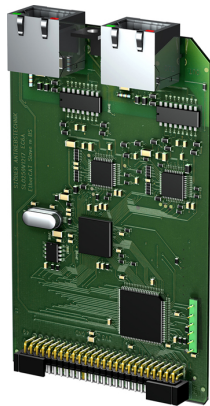

ID No. 138426
 Communication module for the PROFINET connection.

4.4.3 Terminal module

XI6 terminal module

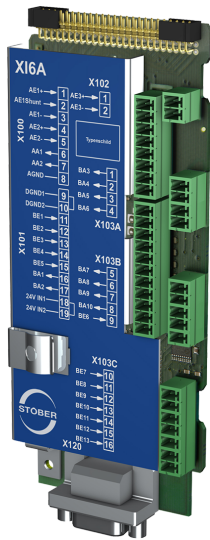

ID no. 138421
 Terminal module for connecting analog and digital signals as well as encoders.

Supported inputs and outputs:

- 13 digital inputs (24 V_{DC})
- 10 digital outputs (24 V_{DC})
- 3 analog inputs (± 10 V_{DC}, 1 x 0 – 20 mA, 16 bits)
- 2 analog outputs (± 10 V_{DC}, 12 bits)

Supported encoders / interfaces:

- SSI encoder (simulation and evaluation)
- TTL incremental encoder, differential (simulation and evaluation)
- HTL incremental encoder, single-ended (simulation and evaluation)
- TTL pulse/direction interface, differential (simulation and evaluation)
- HTL pulse/direction interface, single-ended (simulation and evaluation)

RI6 terminal module



ID no. 138422

Terminal module for connecting analog and digital signals as well as encoders.

Supported inputs and outputs:

- 5 digital inputs ($24 V_{DC}$)
- 2 digital outputs ($24 V_{DC}$)
- 2 analog inputs ($\pm 10 V_{DC}$, $1 \times 0 - 20 \text{ mA}$, 16 bits)
- 2 analog outputs ($\pm 10 V_{DC}$, $\pm 20 \text{ mA}$, 12 bits)

Supported encoders / interfaces:

- Resolver (evaluation)
- EnDat 2.1 sin/cos encoder (evaluation)
- EnDat 2.1/2.2 digital encoder (evaluation)
- Sin/cos encoder (evaluation)
- SSI encoder (simulation and evaluation)
- TTL incremental encoder, differential (simulation and evaluation)
- TTL incremental encoder, single-ended (evaluation)
- HTL incremental encoder, single-ended (simulation and evaluation)
- TTL pulse/direction interface, differential (simulation and evaluation)
- TTL pulse/direction interface, single-ended (evaluation)
- HTL pulse/direction interface, single-ended (simulation and evaluation)

Information

For connecting STOBER EnDat 2.1 sin/cos cables with a 15-pin D-sub connector to an integrated motor temperature sensor, you must use the AP6A02 interface adapter (ID No. 56523), available separately, to lead out the temperature sensor cores.

IO6 terminal module



ID no. 138420

Terminal module for connecting analog and digital signals as well as encoders.

Supported inputs and outputs:

- 5 digital inputs ($24 V_{DC}$)
- 2 digital outputs ($24 V_{DC}$)
- 2 analog inputs ($\pm 10 V_{DC}$, $1 \times 0 - 20 \text{ mA}$, 12 bits)
- 2 analog outputs ($\pm 10 V_{DC}$, $\pm 20 \text{ mA}$, 12 bits)

Supported encoders / interfaces:

- HTL incremental encoder, single-ended (simulation and evaluation)
- HTL pulse/direction interface, single-ended (simulation and evaluation)

4.4.4 DC link connection

If you want to connect SD6 drive controllers in the DC link group, you will need Quick DC-Link modules of type DL6A.

You receive the DL6A rear section modules in different designs for a horizontal connection, suitable for the size of the drive controller.

The quick fastening clamps for attaching the copper rails and an insulation connection piece are contained in the scope of delivery. The copper rails are not included in the scope of delivery. These must have a cross-section of 5 x 12 mm. Insulation end sections are available separately.

DL6A Quick DC-Link for drive controllers

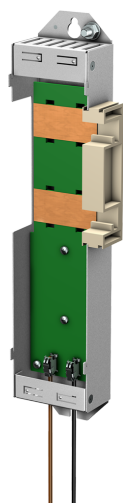

The following designs are available:

DL6A0

ID No. 56440

Rear section module for size 0 drive controller.

DL6A1

ID No. 56441

Rear section module for size 1 drive controller.

DL6A2

ID No. 56442

Rear section module for size 2 drive controller.

DL6A3

ID No. 56443

Rear section module for size 3 drive controller.

DL6A Quick DC-Link insulation end section

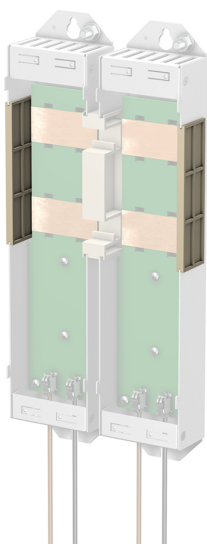

ID No. 56494

Insulation end sections for the left and right termination of the group, 2 pcs.

4.4.5 Braking resistor

In addition to drive controllers, STOBBER offers the following braking resistors described below in various sizes and performance classes. For the selection, note the minimum permitted braking resistors specified in the technical data of the individual drive controller types.

4.4.5.1 Tubular fixed resistor FZMU, FZZMU

Type	FZMU 400×65			FZZMU 400×65		
	49010	55445	55446	53895	55447	55448
ID No.	49010	55445	55446	53895	55447	55448
SD6A02	X	—	—	—	—	—
SD6A04	X	—	—	—	—	—
SD6A06	X	—	—	—	—	—
SD6A14	(X)	—	—	X	—	—
SD6A16	(X)	—	—	X	—	—
SD6A24	(—)	X	—	(X)	X	—
SD6A26	(—)	X	—	(X)	X	—
SD6A34	(—)	(X)	X	(—)	(X)	X
SD6A36	(—)	(X)	X	(—)	(X)	X
SD6A38	(—)	(X)	X	(—)	(X)	X

Tab. 35: Assignment of FZMU, FZZMU braking resistor – SD6 drive controller

X	Recommended
(X)	Possible
(—)	Useful under certain conditions
—	Not possible

Properties

Specification	FZMU 400×65			FZZMU 400×65		
	49010	55445	55446	53895	55447	55448
ID No.	49010	55445	55446	53895	55447	55448
Type	Tubular fixed resistor			Tubular fixed resistor		
Resistance [Ω]	100 $\pm 10\%$	22 $\pm 10\%$	15 $\pm 10\%$	47 $\pm 10\%$	22 $\pm 10\%$	15 $\pm 10\%$
Thermal drift	$\pm 10\%$			$\pm 10\%$		
Power [W]	600			1200		
Therm. time const. τ_{th} [s]	40			40		
Pulse power for < 1 s [kW]	18			36		
U_{max} [V]	848			848		
Weight without packaging [g]	2200			4170		
Protection class	IP20			IP20		
Test symbols	cURus, CE, UKCA			cURus, CE, UKCA		

Tab. 36: FZMU, FZZMU specification

Dimensions

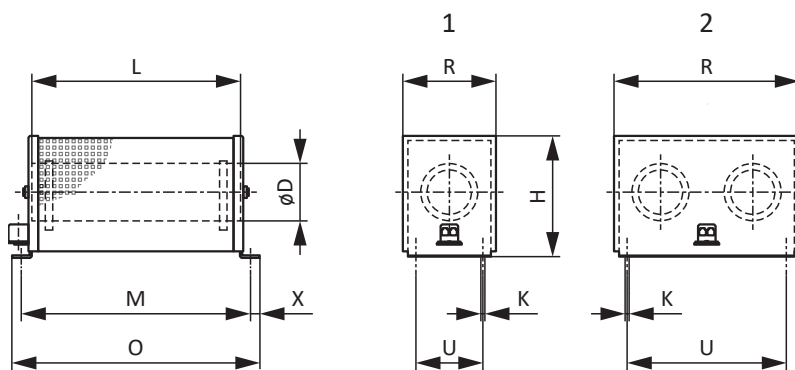

Fig. 4: FZMU (1), FZZMU (2) dimensional drawing

Dimension	FZMU 400×65			FZZMU 400×65		
	49010	55445	55446	53895	55447	55448
L x D	400 × 65			400 × 65		
H	120			120		
K	6.5 × 12			6.5 × 12		
M	430			426		
O	485			485		
R	92			185		
U	64			150		
X	10			10		

Tab. 37: FZMU, FZZMU dimensions [mm]

4.4.5.2 GVADU, GBADU flat resistor

Type	GVADU 210×20	GBADU 265×30	GBADU 405×30	GBADU 335×30	GBADU 265×30
ID No.	55441	55442	55499	55443	55444
SD6A02	X	X	X	—	—
SD6A04	X	X	X	—	—
SD6A06	X	X	X	—	—
SD6A14	(X)	(X)	(X)	X	—
SD6A16	(X)	(X)	(X)	X	—
SD6A24	(—)	(—)	(—)	(X)	X
SD6A26	(—)	(—)	(—)	(X)	X
SD6A34	(—)	(—)	(—)	(—)	(X)
SD6A36	(—)	(—)	(—)	(—)	(X)
SD6A38	(—)	(—)	(—)	(—)	(X)

Tab. 38: Assignment of GVADU, GBADU braking resistor – SD6 drive controller

X	Recommended
(X)	Possible
(—)	Useful under certain conditions
—	Not possible

Properties

Specification	GVADU 210×20	GBADU 265×30	GBADU 405×30	GBADU 335×30	GBADU 265×30
ID No.	55441	55442	55499	55443	55444
Type	Flat resistor				
Resistance [Ω]	100 \pm 10 %	100 \pm 10 %	100 \pm 10 %	47 \pm 10 %	22 \pm 10 %
Thermal drift	\pm 10 %	\pm 10 %	\pm 10 %	\pm 10 %	\pm 10 %
Power [W]	150	300	500	400	300
Therm. time const. τ_{th} [s]	60	60	60	60	60
Pulse power for < 1 s [kW]	3.3	6.6	11	8.8	6.6
U_{max} [V]	848	848	848	848	848
Cable design	Radox	FEP	FEP	FEP	FEP
Cable length [mm]	500	1500	500	1500	1500
Conductor cross-section [AWG]	18/19	14/19	14/19	14/19	14/19
	(0.82 mm ²)	(1.9 mm ²)	(1.9 mm ²)	(1.9 mm ²)	(1.9 mm ²)
Weight without packaging [g]	300	930	1410	1200	930
Protection class	IP54	IP54	IP54	IP54	IP54
Test symbols	cURus, CE, UKCA				

Tab. 39: GVADU, GBADU specification

Dimensions

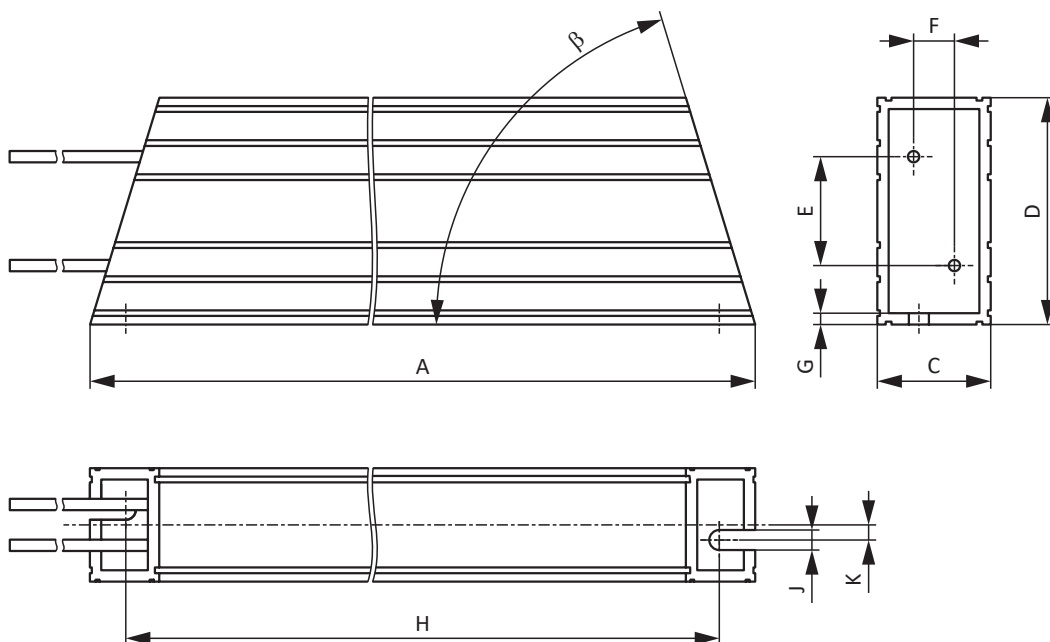

Fig. 5: GVADU, GBADU dimensional drawing

Dimension	GVADU 210×20	GBADU 265×30	GBADU 405×30	GBADU 335×30	GBADU 265×30
ID No.	55441	55442	55499	55443	55444
A	210	265	405	335	265
H	192	246	386	316	246
C	20	30	30	30	30
D	40	60	60	60	60
E	18.2	28.8	28.8	28.8	28.8
F	6.2	10.8	10.8	10.8	10.8
G	2	3	3	3	3
K	2.5	4	4	4	4
J	4.3	5.3	5.3	5.3	5.3
β	65°	73°	73°	73°	73°

Tab. 40: GVADU, GBADU dimensions [mm]

4.4.5.3 FGFKU steel-grid fixed resistor

Type	FGFKU 3100502	FGFKU 3100502	FGFKU 3111202	FGFKU 3121602
ID No.	55449	55450	55451	53897
SD6A24	X	—	—	—
SD6A26	X	—	—	—
SD6A34	(X)	X	X	X
SD6A36	(X)	X	X	X
SD6A38	(X)	X	X	X

Tab. 41: Assignment of FGFKU braking resistor – SD6 drive controller

X	Recommended
(X)	Possible
—	Not possible

Properties

Specification	FGFKU 3100502	FGFKU 3100502	FGFKU 3111202	FGFKU 3121602
ID No.	55449	55450	55451	53897
Type	Steel-grid fixed resistor			
Resistance [Ω]	22 \pm 10 %	15 \pm 10 %	15 \pm 10 %	15 \pm 10 %
Thermal drift	\pm 10 %	\pm 10 %	\pm 10 %	\pm 10 %
Power [W]	2500	2500	6000	8000
Therm. time const. τ_{th} [s]	30	30	20	20
Pulse power for < 1 s [kW]	50	50	120	160
U_{max} [V]	848	848	848	848
Weight without packaging [g]	7500	7500	12000	18000
Protection class	IP20	IP20	IP20	IP20
Test symbols	cURus, CE, UKCA			

Tab. 42: FGFKU specification

Dimensions

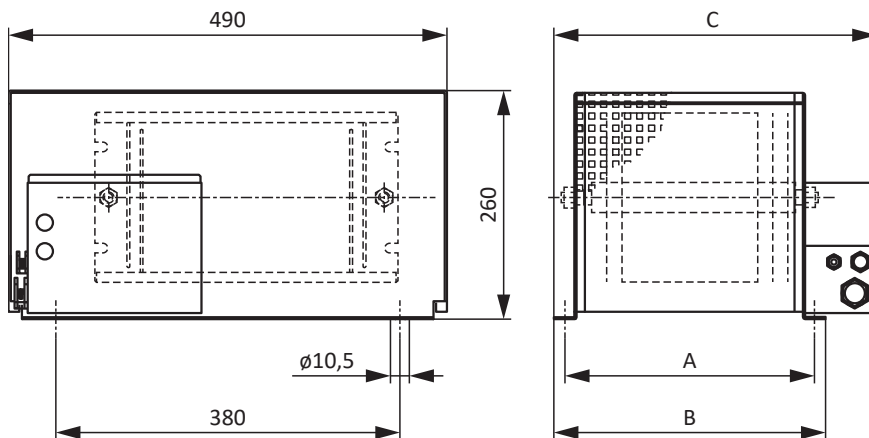

Fig. 6: FGFKU dimensional drawing

Dimension	FGFKU 3100502	FGFKU 3100502	FGFKU 3111202	FGFKU 3121602
ID No.	55449	55450	55451	53897
A	270	270	370	570
B	295	295	395	595
C	355	355	455	655

Tab. 43: FGFKU dimensions [mm]

4.4.5.4 Rear section braking resistor RB 5000

Type	RB 5022	RB 5047	RB 5100
ID No.	45618	44966	44965
SD6A02	—	—	X
SD6A04	—	—	X
SD6A06	—	—	X
SD6A14	—	X	(X)
SD6A16	—	X	(X)
SD6A24	X	—	—
SD6A26	X	—	—
SD6A34	—	—	—
SD6A36	—	—	—
SD6A38	—	—	—

Tab. 44: Assignment of RB 5000 braking resistor – SD6 drive controller

X	Recommended
(X)	Possible
—	Not possible

Properties

Specification	RB 5022	RB 5047	RB 5100
ID No.	45618	44966	44965
Resistance [Ω]	22 \pm 10 %	47 \pm 10 %	100 \pm 10 %
Thermal drift	\pm 10 %	\pm 10 %	\pm 10 %
Power [W]	100	60	60
Therm. time const. τ_{th} [s]	8	8	8
Pulse power for < 1 s [kW]	1.5	1.0	1.0
U_{max} [V]	800	800	800
Weight without packaging [g]	640	460	440
Cable design	Radox	Radox	Radox
Cable length [mm]	250	250	250
Conductor cross-section [AWG]	18/19	18/19	18/19
	(0.82 mm ²)	(0.82 mm ²)	(0.82 mm ²)
Maximum torque of M5 threaded bolts [Nm]	5	5	5
Protection class	IP40	IP40	IP40
Test symbols	cURus, CE, UKCA	cURus, CE, UKCA	cURus, CE, UKCA

Tab. 45: RB 5000 specification

Dimensions

Dimension	RB 5022	RB 5047	RB 5100
ID No.	45618	44966	44965
Height	300	300	300
Width	94	62	62
Depth	18	18	18
Drilling diagram corresponds to size	Size 2	Size 1	Size 0 and Size 1

Tab. 46: RB 5000 dimensions [mm]

4.4.6 Choke

Technical specifications for suitable chokes can be found in the following chapters.

4.4.6.1 TEP power choke

For each size 3 SD6 drive controller, you need one power choke. It dampens voltage and current peaks and reduces the load of the drive controller power feed-in.

Properties

Specification	TEP4010-2US00
ID No.	56528
Phases	3
Thermally allowed continuous current	100 A
Nominal current $I_{N,MF}$	90 A
Absolute loss P_V	103 W
Inductance	0.14 mH
Voltage range	3 × 400 V _{AC} +32%/−50% 3 × 480 V _{AC} +10%/−58%
Voltage drop U_k	2%
Frequency range	50/60 Hz
Protection class	IP00
Max. surrounding temperature $\vartheta_{amb,max}$	40 °C
Insulation class	B
Connection	Screw terminal
Connection type	Flexible with and without end sleeve
Max. conductor cross-section	6 – 35 mm ²
Tightening torque	2.5 Nm
Insulation stripping length	17 mm
Installation	Screws
Directive	EN 61558-2-20
UL Recognized Component (CAN; USA)	Yes
Test symbol, symbol	 cURus, CE,

Tab. 47: TEP specification

Dimensions

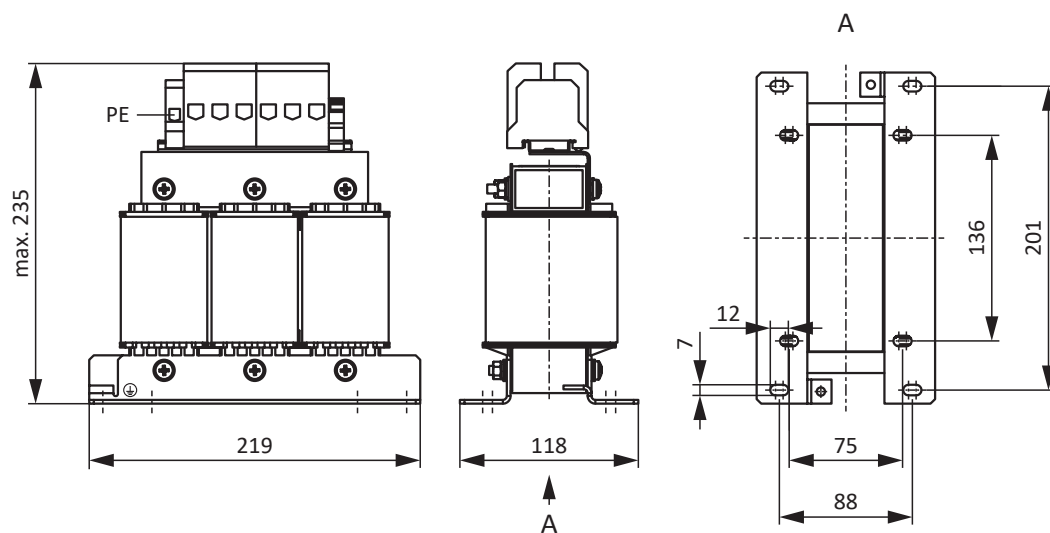

Fig. 7: Power choke dimensional drawing

Dimensions	TEP4010-2US00
Height [mm]	235
Width [mm]	219
Depth [mm]	118
Vertical distance 1 – fastening holes [mm]	201
Vertical distance 2 – Fastening holes [mm]	136
Horizontal distance 1 – fastening holes [mm]	88
Horizontal distance 2 – Fastening holes [mm]	75
Drill holes – Depth [mm]	7
Drill holes – Width [mm]	12
Screw connection – M	M6
Weight without packaging [g]	9900

Tab. 48: TEP dimensions and weight

4.4.6.2 TEP output choke

Output chokes are required for connecting size 0 to 2 drive controllers from a cable length > 50 m in order to reduce interference pulses and protect the drive system.

Information

The following technical data only applies to a rotating magnetic field frequency of 200 Hz. For example, this rotating magnetic field frequency is achieved with a motor with 4 pole pairs and a nominal speed of 3000 rpm. Always observe the specified derating for higher rotating magnetic field frequencies. Also observe the relationship with the clock frequency.

Properties

Specification	TEP3720-0ES41	TEP3820-0CS41	TEP4020-0RS41
ID No.	53188	53189	53190
Voltage range	3 × 0 to 480 V _{AC}		
Frequency range	0 – 200 Hz		
Nominal current I _{N,MF} at 4 kHz	4 A	17.5 A	38 A
Nominal current I _{N,MF} at 8 kHz	3.3 A	15.2 A	30.4 A
Max. permitted motor cable length with output choke	100 m		
Max. surrounding temperature $\vartheta_{amb,max}$	40 °C		
Protection class	IP00		
Winding losses	11 W	29 W	61 W
Iron losses	25 W	16 W	33 W
Connection	Screw terminal		
Max. conductor cross-section	10 mm ²		
UL Recognized Component (CAN; USA)	Yes		
Test symbols	cURus, CE		

Tab. 49: TEP specification

Dimensions

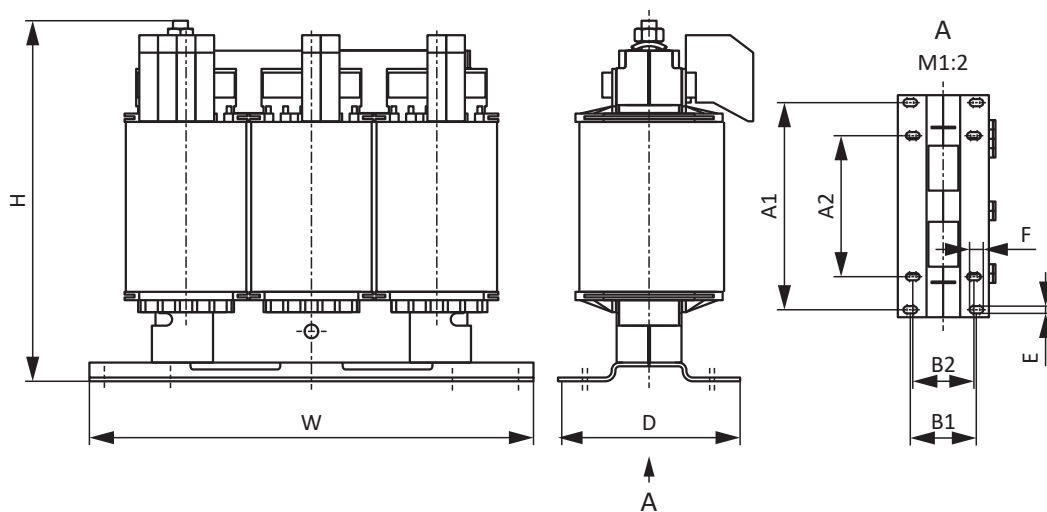

Fig. 8: TEP dimensional drawing

Dimension	TEP3720-0ES41	TEP3820-0CS41	TEP4020-0RS41
Height H [mm]	Max. 153	Max. 153	Max. 180
Width W [mm]	178	178	219
Depth D [mm]	73	88	119
Vertical distance – Fastening holes A1 [mm]	166	166	201
Vertical distance – Fastening holes A2 [mm]	113	113	136
Horizontal distance – Fastening holes B1 [mm]	53	68	89
Horizontal distance – Fastening holes B2 [mm]	49	64	76
Drill holes – Depth E [mm]	5.8	5.8	7
Drill holes – Width F [mm]	11	11	13
Screw connection – M	M5	M5	M6
Weight without packaging [g]	2900	5900	8800

Tab. 50: TEP dimensions and weight

4.4.7 EMC shroud

You can use the EM6A EMC shroud to connect the cable shield of the power cable. Two different designs are available.

EM6A0 EMC shroud



ID No. 56459

EMC shroud for the SD6 drive controller up to size 2.

Accessory part for shield connection of the power cable.

Can be attached to the basic housing.

Including shield connection terminal.

EMC shroud EM6A3

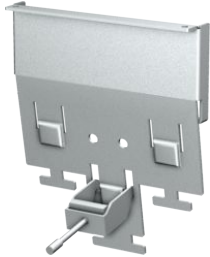

ID No. 56521

EMC shroud for drive controllers of the MDS 5000, SDS 5000 and SD6 series.

Accessory part for shield connection of the power cable for drive controllers up to size 3.

Can be attached to the basic housing.

Including shield connection terminal.

If necessary you can also connect the cable shield of the braking resistor and DC link connection to the shroud.

4.4.8 Encoder adapter box

LA6A00 encoder adapter box



ID No. 56510

Interface adapter for differential TTL incremental signals and single-ended TTL Hall sensor signals.

The adapter converts and transmits TTL signals from synchronous linear motors to the SD6 drive controller. A variable, internal interface converts the input signals appropriately for the STOBER standard interfaces.

X120 SSI/TTL connection cable



ID No. 49482

Cable for connecting the X120 TTL interface on the SD6 drive controller (on terminal module RI6 or XI6) with the X301 interface on the LA6 adapter box in order to transfer Hall sensor signals. 0.3 m.

LA6 / AX 5000 connection cable



Cable for connecting the X4 connection on the SD6 drive controller to X300 on the LA6 adapter box in order to transmit incremental encoder signals.

The following designs are available:

ID No. 45405: 0.5 m.

ID No. 45386: 2.5 m.

4.4.9 Encoder battery module

Absolute Encoder Support AES



ID No. 55452

Battery module for buffering the supply voltage when using the EnDat 2.2 digital inductive encoder with battery-buffered multi-turn stage, for example EBI1135 or EBI135.

A battery is included.

Information

Note that a 15-pin extension cable between the socket and the AES may be necessary for the connection to the drive controller due to limited space.

- A commercially available shielded extension cable with a 15-pin D-sub connector and a length of ≤ 1 m can be used between the socket and the AES.

AES replacement battery



ID No. 55453

Replacement battery for AES battery module.

4.4.10 Removable data storage

Paramodul removable data storage

Included in the standard version.



ID No. 56403

The plug-in Paramodul with integrated microSD card (from 512 MB, industrial type) is available as a storage medium.

4.5 Further information

4.5.1 Directives and standards

The following European directives and standards are relevant to the drive controllers:

- Machinery Directive 2006/42/EC
- Low Voltage Directive 2014/35/EU
- EMC Directive 2014/30/EU
- EN ISO 13849-1:2015
- EN ISO 13849-2:2012
- EN 61800-3:2004 and A1:2012
- EN 61800-5-1:2007
- EN 61800-5-2:2007

4.5.2 Symbols, marks and test symbols



Choke without overload protection in accordance with EN 61558-2-20.



Grounding symbol

Grounding symbol in accordance with IEC 60417, symbol 5019.



RoHS lead-free mark

Marking in accordance with RoHS directive 2011-65-EU.



CE mark

Manufacturer's self declaration: The product meets the requirements of EU directives.



UKCA test symbol

Manufacturer's self declaration: The product meets the requirements of UK directives.



UL test symbol

This product is listed by UL for the United States and Canada. Representative samples of this product have been evaluated by UL and meet the requirements of applicable standards.



UL recognized component mark

This component or material is recognized by UL. Representative samples of this product have been evaluated by UL and meet applicable requirements.

4.5.3 Additional documentation

Additional documentation related to the product can be found at

<http://www.stoeber.de/en/downloads/>

Enter the ID of the documentation in the Search field.

Documentation	ID
SD6 drive controller manual	442426
SE6 safety module manual	442796

5 POSIDYN SDS 5000 servo inverters

Table of contents

5.1	Overview	134
5.1.1	Features.....	135
5.1.2	Software components	137
5.1.3	Application training.....	138
5.2	Technical data	139
5.2.1	Type designation	139
5.2.2	Sizes.....	139
5.2.3	General technical data	140
5.2.4	Electrical data.....	141
5.2.5	Derating by increasing the clock frequency	147
5.2.6	Dimensions.....	148
5.2.7	Minimum clearances.....	150
5.3	Inverter/motor combination.....	151
5.4	Accessories	153
5.4.1	Safety technology.....	153
5.4.2	Communication	153
5.4.3	Terminal module	155
5.4.4	Braking resistor	156
5.4.5	Choke	163
5.4.6	Brake module and EMC shroud.....	165
5.4.7	Axis switcher	165
5.4.8	Encoder battery module	166
5.4.9	Removable data storage	166
5.5	Further information	167
5.5.1	Directives and standards.....	167
5.5.2	Symbols, marks and test symbols	167
5.5.3	Additional documentation	167



5

Servo inverters

POSIDYN SDS 5000

5.1 Overview

High dynamics for fully digital servo axes

Features

- Nominal output current up to 60 A (at 8 kHz clock frequency)
- 250% overload capacity
- Power range: 0.75 kW to 45 kW
- Control of rotary synchronous servo motors and asynchronous motors
- Multi-functional encoder interfaces
- Automatic motor parameterization from the electronic motor nameplate
- Isochronic system bus (IGB motion bus) for parameterization and multi-axis applications
- Communication using PROFIBUS DP, PROFINET, CANopen or EtherCAT
- Safe Torque Off (STO) and Safe Stop 1 (SS1) safety functions: SIL 3, PL e (cat. 3)
- Digital and analog inputs and outputs as an option
- Brake chopper, brake control and line filter
- Convenient operating unit consisting of plain-text display and buttons
- Paramodul removable data storage

5.1.1 Features

The 5th generation series of STOBER inverters are purely digital, modular inverter systems for operating rotary synchronous and asynchronous motors. It includes product types for direct operation on a one or three-phase network in a voltage range from 200 V_{AC} to 528 V_{AC}. An EMC line filter is integrated. EnDat 2.1/2.2 digital, SSI and incremental (HTL/TTL) are available as encoder interfaces in the standard design. A resolver evaluation is available as an option. The inverter can be adapted to the requirements of individual applications using different option modules. The ASP 5001 safety module makes it possible to implement the Safe Torque Off (STO) and Safe Stop 1 (SS1) safety functions in accordance with DIN EN ISO 13849-1 and DIN EN 61800-5-2 for safety-relevant applications. Communication modules provide the connection to a controller over the PROFIBUS DP, PROFINET, CANopen or EtherCAT fieldbus. In addition, terminal modules are available for connecting analog and digital signals as well as additional encoder signals. A plain text display and keyboard simplify diagnostics in the event of a fault and enable fast access to parameters. The Paramodul removable data storage can be used to transfer all application-relevant data from one inverter to another.

STOBER synchronous servo motors are ideally intended for operation with the EnDat 2.1/2.2 digital encoder. These encoder systems can deliver the highest control quality. Motor parameterization can be derived automatically from the electronic motor nameplate.



POSIDYN SDS 5000

Sequential axis switching with POSISwitch AX 5000

The POSISwitch AX 5000 accessory allows for up to four synchronous servo motors to be operated on one inverter sequentially using the EnDat 2.1/2.2 digital absolute encoder. The POSISwitch AX 5000 module is used to switch absolute encoder signals as well as control signals for brake and motor line switching. Switching is easy and EMC interference-free thanks to the entirely digital encoder signals with EnDat protocol.

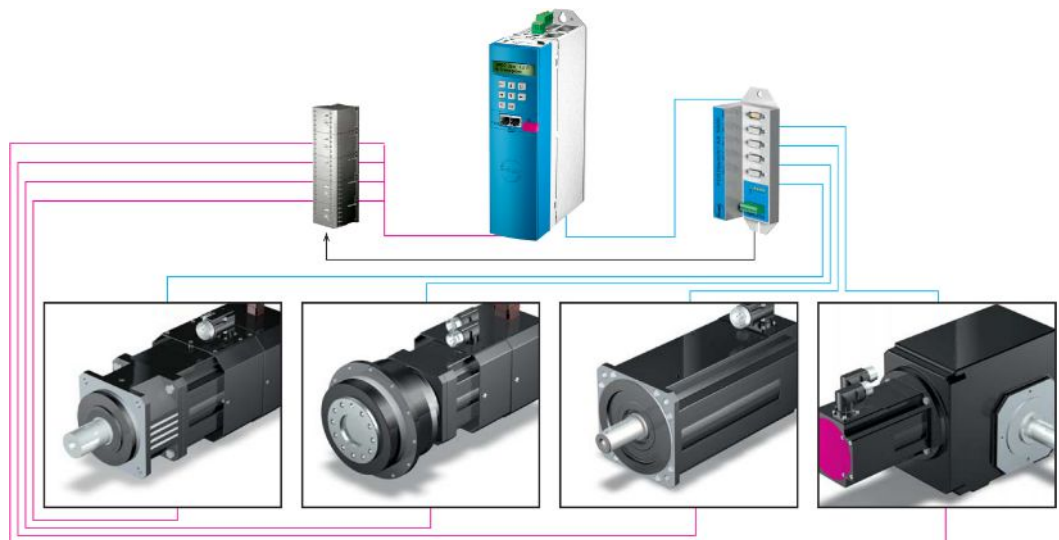

Integrated bus (IGB) for performance, convenience and safety

SDS 5000 servo inverters feature two interfaces for the integrated bus in the standard version. The integrated bus is used for easy configuration over Ethernet and isochronic data exchange for the following functions:

- Multi-axis synchronization between the servo inverters (IGB motion bus)
- Internet connection for remote maintenance of individual and multiple inverters
- Direct connection between servo inverter and PC

IGB motion bus

The IGB motion bus allows for cyclic, isochronic data exchange between multiple POSIDYN SDS 5000 units integrated into the IGB network. In addition to transferring guide values for master/slave operation, any other data items can also be exchanged, such as tailor-made applications.



STOBER remote maintenance concept

STOBER remote maintenance enables commissioning software to be used to perform all processes and sequences just like an on-site service visit. The concept guides users through a controlled and protected procedure. It ensures that the person responsible for the machine is there on site to pay attention to special situations and personal safety. On the other end, the remote maintenance specialist has the assurance of communicating with a responsible employee on site who is monitoring the situation on the machine.

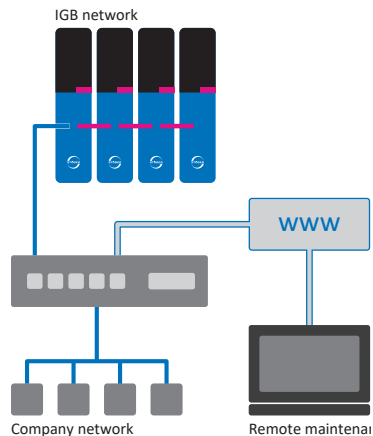

Remote maintenance enables all processes and sequences to be performed just like an on-site service visit.

Brake management

Using the optional BRS 5001 brake module, the POSIDYN SDS 5000 servo inverter can activate one or two 24 V_{DC} brake systems. Brake management provides the following functions for both brake systems:

- Cyclic brake test
- Bed in brake



Optionally available: BRS 5001 brake module

POSITool

The 5th generation of POSITool project configuration and commissioning software has all the functions needed for efficient use of inverters in single and multi-axis applications.

Paramodul removable data storage

Removable data storage for fast series commissioning by copying and easy service when replacing devices.



5.1.2 Software components

Modular application software

Various standard applications can be loaded onto the devices of the 5th STÖBER inverter generation with the POSITool commissioning software as needed. Furthermore, programming based on IEC 61131-3 with CFC can be used to create new applications or expand existing ones. The inverter operating system is multi-axis capable. It supports up to four axes with separate application and parameter ranges.

Velocity mode (standard application)

- **Fast set value**

Simple speed application for lean applications. The speed reference value and torque limiting can be specified using analog inputs as well as digitally.

Torque/force and velocity mode (standard application)

- **Comfort set value**

Expanded torque and speed set value application. Set values and limits can be assigned with the fast set value as well as using fixed values, motor potentiometers and other functions.

- **Technology controller**

PID controller for torque or speed-controlled applications.

Positioning and master/slave mode (standard application)

- **Command, synchronous command**

High-performance positioning application with a command interface based on PLCopen. The data for a motion task including target position, velocity and acceleration are transferred together over fieldbus to the inverter, which then processes them independently. The functional scope is rounded out by an electrical cam, motion block switching point and Posi-Latch.

- **Motion block**

Extensive positioning application with up to 256 motion blocks based on PLCopen. The motion blocks can be selected individually over fieldbus or with digital inputs. They can also be started in a chain. The functional scope is rounded out by an electrical cam and Posi-Latch.

Electronic cam disk with PLCopen interface (tailor-made applications)

The electronic cam disk application makes it possible to implement complex motion tasks such as:

- Flying saw
- Synchronizer (clock in/clock out)
- Cross cutter
- Welding bar/embossing stamp
- Print mark control

These applications can be implemented quickly and easily using readily understandable, free graphical programming based on IEC 61131-3 CFC. This also allows for customer-specific adaptations to special system conditions. Function blocks based on PLCopen Motion Control are available for this purpose for trained users.

5.1.3 Application training

STOBER offers a multi-level training program that is essentially focused on the inverter.

G5 Basic

Training content: System overview, installation and commissioning of the inverter. Use of option modules. Parameterization, commissioning and diagnostics using the integrated display and commissioning software. Remote maintenance. Basics of controller optimization. Configuration of the drive train. Integrated software functions. Software applications. Connection to a higher-level controller. Basics of safety technology. Practical exercises on training topics.

Software used: POSITool.

G5 Customized

Training content: Graphical programming with CFC. Special knowledge for regulating, control and safety technology. Electronic cam disk. Practical exercises on training topics.

5.2 Technical data

Technical data for inverters can be found in the following sections.

5.2.1 Type designation

SDS	5	075	A
-----	---	-----	---

Tab. 1: Example code for type designation

Code	Designation	Design
SDS	Series	
5	Generation	Generation 5
075	Power	075 = 7.5 kW
–	Hardware variants	No identification: HW 199 or lower
A		A: HW 200 or higher

Tab. 2: Meaning of the example code

5.2.2 Sizes

Type	ID No.	Size
SDS 5007A	55428	Size 0
SDS 5008A	55429	Size 0
SDS 5015A	55430	Size 0
SDS 5040A	55431	Size 1
SDS 5075A	55432	Size 1
SDS 5110A	55433	Size 2
SDS 5150A	55434	Size 2
SDS 5220A	55435	Size 3
SDS 5370A	55436	Size 3
SDS 5450A	55437	Size 3

Tab. 3: Available SDS 5000 types and sizes



SDS 5000 in sizes 3, 2, 1 and 0

5.2.3 General technical data

The following information applies to all inverter types.

Device features	
Protection class of the device	IP20
Protection class of the installation space	At least IP54
Protection class	Protection class I in accordance with EN 61140
Radio interference suppression	Integrated line filter in accordance with EN 61800-3, interference emission class C3
Overvoltage category	III in accordance with EN 61800-5-1
Test symbols	CE, cULus, RoHS

Tab. 4: Device features

Transport and storage conditions	
Storage/transport temperature	-20 °C to +70 °C Maximum change: 20 K/h
Relative humidity	Maximum relative humidity 85%, non-condensing
Vibration (transport) in accordance with EN 60068-2-6	5 Hz ≤ f ≤ 9 Hz: 3.5 mm 9 Hz ≤ f ≤ 200 Hz: 10 m/s ² 200 Hz ≤ f ≤ 500 Hz: 15 m/s ²
Fall height for freefall ¹ Weight < 100 kg in accordance with EN 61800-2 (or IEC 60721-3-2, class 2M1)	0.25 m

Tab. 5: Transport and storage conditions

Operating conditions	
Surrounding temperature during operation	0 °C to 45 °C with nominal data 45 °C to 55 °C with derating -2.5% / K
Relative humidity	Maximum relative humidity 85%, non-condensing
Installation altitude	0 m to 1000 m above sea level without restrictions 1000 m to 2000 m above sea level with -1.5%/100 m derating
Pollution degree	Pollution degree 2 in accordance with EN 50178
Ventilation	Installed fan
Vibration (operation) in accordance with EN 60068-2-6	5 Hz ≤ f ≤ 9 Hz: 0.35 mm 9 Hz ≤ f ≤ 200 Hz: 1 m/s ²

Tab. 6: Operating conditions

Discharge times	
Self-discharge of DC link	6 min

Tab. 7: Discharge times of the DC link circuit

5.2.4 Electrical data

The electrical data of the available sizes as well as the properties of the brake chopper can be found in the following sections.

An explanation of the symbols used for formulas can be found in Chapter [\[9.1 \]](#).

5.2.4.1 Size 0: SDS 5007A to SDS 5015A

Electrical data	SDS 5007A	SDS 5008A	SDS 5015A
ID No.	55428	55429	55430
Recommended motor rating	0.75 kW	0.75 kW	1.5 kW
U_{1PU}	1 × 230 V, +20% / -40%, 50/60 Hz	3 × 400 V, +32% / -50%, 50 Hz; 3 × 480 V, +10% / -58%, 60 Hz	
$I_{1N,PU}$	1 × 5.9 A	3 × 2.2 A	3 × 4 A
f_{2PU}	0 – 700 Hz		
U_{2PU}	0 – 230 V	0 – 400 V	
U_{maxPU}	440 V	830 V	

Tab. 8: SDS 5000 electrical data, size 0

Nominal currents up to +45 °C (in the control cabinet)

Operation with asynchronous motor

Electrical data	SDS 5007A	SDS 5008A	SDS 5015A
$I_{2N,PU}$	3 × 4 A	3 × 2.3 A	3 × 4.5 A
I_{2maxPU}	180% for 5 s; 150% for 30 s		
$f_{PWM,PU}$	4 kHz ²		

Tab. 9: SDS 5000 electrical data, size 0, for 4 kHz clock frequency

Operation with synchronous servo motor

Electrical data	SDS 5007A	SDS 5008A	SDS 5015A
$I_{2N,PU}$	3 × 3 A	3 × 1.7 A	3 × 3.4 A
I_{2maxPU}	250% for 2 s; 200% for 5 s		
$f_{PWM,PU}$	8 kHz ³		

Tab. 10: SDS 5000 electrical data, size 0, for 8 kHz clock frequency

Electrical data	SDS 5007A	SDS 5008A	SDS 5015A
U_{onCH}	400 – 420 V	780 – 800 V	
U_{offCH}	360 – 380 V	740 – 760 V	
R_{2minRB}	100 Ω	100 Ω	
P_{maxRB}	1.8 kW	6.4 kW	

Tab. 11: Brake chopper electrical data, size 0

² Clock frequency adjustable from 4 to 16 kHz (see the chapter on derating)

³ Clock frequency adjustable from 4 to 16 kHz (see the chapter on derating)

5.2.4.2 Size 1: SDS 5040A to SDS 5075A

Electrical data	SDS 5040A	SDS 5075A
ID No.	55431	55432
Recommended motor rating	4.0 kW	7.5 kW
U_{1PU}	3 × 400 V, +32% / -50%, 50 Hz; 3 × 480 V, +10% / -58%, 60 Hz	
$I_{1N,PU}$	3 × 9.3 A	3 × 15.8 A
f_{2PU}	0 – 700 Hz	
U_{2PU}	0 – 400 V	
U_{maxPU}	830 V	

Tab. 12: SDS 5000 electrical data, size 1

Nominal currents up to +45 °C (in the control cabinet)

Operation with asynchronous motor

Electrical data	SDS 5040A	SDS 5075A
$I_{2N,PU}$	3 × 10 A	3 × 16 A
I_{2maxPU}	180% for 5 s; 150% for 30 s	
$f_{PWM,PU}$	4 kHz ⁴	

Tab. 13: SDS 5000 electrical data, size 1, for 4 kHz clock frequency

Operation with synchronous servo motor

Electrical data	SDS 5040A	SDS 5075A
$I_{2N,PU}$	3 × 6 A	3 × 10 A
I_{2maxPU}	250% for 2 s; 200% for 5 s	
$f_{PWM,PU}$	8 kHz ⁵	

Tab. 14: SDS 5000 electrical data, size 1, for 8 kHz clock frequency

Electrical data	SDS 5040A	SDS 5075A
U_{onCH}	780 – 800 V	
U_{offCH}	740 – 760 V	
R_{2minRB}	47 Ω	47 Ω
P_{maxRB}	13.6 kW	13.6 kW

Tab. 15: Brake chopper electrical data, size 1

⁴ Clock frequency adjustable from 4 to 16 kHz (see the chapter on derating)⁵ Clock frequency adjustable from 4 to 16 kHz (see the chapter on derating)

5.2.4.3 Size 2: SDS 5110A to SDS 5150A

Electrical data	SDS 5110A	SDS 5150A
ID No.	55433	55434
Recommended motor rating	11 kW	15 kW
U_{1PU}	3 × 400 V, +32% / -50%, 50 Hz; 3 × 480 V, +10% / -58%, 60 Hz	
$I_{1N,PU}$	3 × 24.5 A	3 × 32.6 A
f_{2PU}	0 – 700 Hz	
U_{2PU}	0 – 400 V	
U_{maxPU}	830 V	

Tab. 16: SDS 5000 electrical data, size 2

Nominal currents up to +45 °C (in the control cabinet)

Operation with asynchronous motor

Electrical data	SDS 5110A	SDS 5150A
$I_{2N,PU}$	3 × 22 A	3 × 32 A
I_{2maxPU}	180% for 5 s; 150% for 30 s	
$f_{PWM,PU}$	4 kHz ⁶	

Tab. 17: SDS 5000 electrical data, size 2, for 4 kHz clock frequency

Operation with synchronous servo motor

Electrical data	SDS 5110A	SDS 5150A
$I_{2N,PU}$	3 × 14 A	3 × 20 A
I_{2maxPU}	250% for 2 s; 200% for 5 s	
$f_{PWM,PU}$	8 kHz ⁷	

Tab. 18: SDS 5000 electrical data, size 2, for 8 kHz clock frequency

Electrical data	SDS 5110A	SDS 5150A
U_{onCH}	780 – 800 V	
U_{offCH}	740 – 760 V	
R_{2minRB}	22 Ω	
P_{maxRB}	29.1 kW	

Tab. 19: Brake chopper electrical data, size 2

⁶ Clock frequency adjustable from 4 to 16 kHz (see the chapter on derating)⁷ Clock frequency adjustable from 4 to 16 kHz (see the chapter on derating)

5.2.4.4 Size 3: SDS 5220A to SDS 5450A

Electrical data	SDS 5220A	SDS 5370A	SDS 5450A
ID No.	55435	55436	55437
Recommended motor rating	22 kW	37 kW	45 kW
U_{1PU}		3 × 400 V, +32% / -50%, 50 Hz; 3 × 480 V, +10% / -58%, 60 Hz	
$I_{1N,PU}$	1 × 37 A	3 × 62 A	3 × 76 A
f_{2PU}		0 – 700 Hz	
U_{2PU}		0 – 400 V	
U_{maxPU}		830 V	

Tab. 20: SDS 5000 electrical data, size 3

Nominal currents up to +45 °C (in the control cabinet)

Operation with asynchronous motor

Electrical data	SDS 5220A	SDS 5370A	SDS 5450A
$I_{2N,PU}$	3 × 44 A	3 × 70 A	3 × 85 A
I_{2maxPU}	180% for 5 s; 150% for 30 s		
$f_{PWM,PU}$	4 kHz ⁸		

Tab. 21: SDS 5000 electrical data, size 3, for 4 kHz clock frequency

Operation with synchronous servo motor

Electrical data	SDS 5220A	SDS 5370A	SDS 5450A
$I_{2N,PU}$	3 × 30 A	3 × 50 A	3 × 60 A
I_{2maxPU}	250% for 2 s; 200% for 5 s		
$f_{PWM,PU}$	8 kHz ⁹		

Tab. 22: SDS 5000 electrical data, size 3, for 8 kHz clock frequency

Electrical data	SDS 5220A	SDS 5370A	SDS 5450A
U_{onCH}		780 – 800 V	
U_{offCH}		740 – 760 V	
R_{intRB}	30 Ω (PTC resistance; 100 W; max. 1 kW for 1 s; $\tau = 40$ s)		
R_{2minRB}		15 Ω	
P_{maxRB}		42 kW	

Tab. 23: Brake chopper electrical data, size 3

⁸ Clock frequency adjustable from 4 to 16 kHz (see the chapter on derating)⁹ Clock frequency adjustable from 4 to 16 kHz (see the chapter on derating)

5.2.4.5 Power loss data in accordance with EN 61800-9-2

Type	Nominal current $I_{2N,PU}$	Apparent power	Absolute losses $P_{V,CU}^{10}$	Operating points ¹¹								IE class ¹²
				(0/25)	(0/50)	(0/100)	(50/25)	(50/50)	(50/100)	(90/50)	(90/100)	
				Relative losses								
				[%]								
	[A]	[kVA]	[W]									
SDS 5007A	4	0.9	10	5.01	5.07	5.68	5.20	5.37	6.30	5.88	7.43	IE2
SDS 5008A	2.3	1.6	10	2.98	3.13	3.49	3.02	3.22	3.71	3.36	4.09	IE2
SDS 5015A	4.5	3.1	12	1.71	1.86	2.24	1.75	1.97	2.51	2.16	3.04	IE2
SDS 5040A	10	6.9	12	1.38	1.54	1.93	1.43	1.64	2.17	1.80	2.57	IE2
SDS 5075A	16	11.1	12	0.95	1.12	1.66	0.99	1.23	1.98	1.41	2.52	IE2
SDS 5110A	22	15.2	15	0.80	0.97	1.49	0.84	1.06	1.75	1.21	2.19	IE2
SDS 5150A	32	22.2	15	0.70	0.87	1.40	0.74	0.97	1.66	1.11	2.08	IE2
SDS 5220A	44	30.5	35	0.61	0.76	1.21	0.68	0.90	1.53	1.06	1.96	IE2
SDS 5370A	70	48.5	35	0.53	0.69	1.18	0.59	0.82	1.49	0.97	1.89	IE2
SDS 5450A	85	58.9	35	0.47	0.64	1.18	0.54	0.78	1.50	0.94	1.94	IE2

Tab. 24: Relative losses of SDS 5000 inverters according to EN 61800-9-2

¹⁰ Absolute losses for a power unit that is switched off¹¹ Operating points for relative motor stator frequency in % and relative torque current in %¹² IE class in accordance with EN 61800-9-2

Type	Nominal current $I_{2N,PU}$	Apparent power	Absolute losses $P_{V,CU}^{13}$	Operating points ¹⁴								IE class ¹⁵	Comparison ¹⁶
				(0/25)	(0/50)	(0/100)	(50/25)	(50/50)	(50/100)	(90/50)	(90/100)		
				Absolute losses P_V									
			[W]	[W]									[%]
SDS 5007A	4	0.9	10	45.1	45.6	51.1	46.8	48.3	56.7	52.9	66.9	IE2	51.8
SDS 5008A	2.3	1.6	10	47.7	50.1	55.8	48.3	51.5	59.3	53.8	65.4	IE2	40.2
SDS 5015A	4.5	3.1	12	52.9	57.6	69.3	54.4	61.0	77.9	67.1	94.1	IE2	39.6
SDS 5040A	10	6.9	12	95.3	106.1	133.3	98.6	113.2	149.9	123.9	177.0	IE2	37.1
SDS 5075A	16	11.1	12	104.9	124.0	184.6	110.3	136.6	219.8	156.0	279.8	IE2	35.8
SDS 5110A	22	15.2	15	121.5	146.9	226.1	128.1	161.6	266.0	183.7	332.7	IE2	32.9
SDS 5150A	32	22.2	15	154.7	192.8	311.3	164.6	214.6	369.3	245.9	462.1	IE2	38.3
SDS 5220A	44	30.5	35	187.5	232.2	368.7	207.7	273.9	466.8	323.0	597.8	IE2	32.1
SDS 5370A	70	48.5	35	256.6	332.3	570.8	287.9	397.0	721.5	471.0	915.9	IE2	33.9
SDS 5450A	85	58.9	35	277.8	376.9	692.3	317.4	459.0	886.1	554.6	1143.1	IE2	35.3

Tab. 25: Absolute losses in SDS 5000 inverters in accordance with EN 61800-9-2

General conditions

The loss data applies to inverters without accessories.

The power loss calculation is based on a three-phase supply voltage with 400 V_{AC}/50 Hz.

The calculated data includes a supplement of 10% in accordance with EN 61800-9-2.

The power loss specifications refer to a clock frequency of 4 kHz.

The absolute losses for a power unit that is switched off refer to the 24 V_{DC} power supply of the control electronics.

¹³ Absolute losses for a power unit that is switched off

¹⁴ Operating points for relative motor stator frequency in % and relative torque current in %

¹⁵ IE class in accordance with EN 61800-9-2

¹⁶ Comparison of the losses for the reference inverter related to IE2 in the nominal point (90, 100)

5.2.4.6 Power loss data of accessories

If the inverter needs to be ordered with accessory parts, the losses increase as follows:

Type	Absolute losses P_v [W]
ASP 5001 safety module	1
SEA 5001 terminal module	< 2
XEA 5001 terminal module	< 5
REA 5001 terminal module	< 5
CAN 5000 communication module	1
DP 5000 communication module	< 2
ECS 5000 communication module	< 2
PN 5000 communication module	< 4
BRM 5000 / BRS 5001 brake module	< 1

Tab. 26: Absolute losses of the accessories

Information

Note the absolute power loss of the encoder (usually < 3 W) and of the brake when designing as well.

Loss specifications for other optional accessories can be found in the technical data of the respective accessory part.

5.2.5 Derating by increasing the clock frequency

Depending on the clock frequency $f_{PWM,PU}$, the following values for nominal output currents $I_{2N,PU}$ arise. Note that only 8 kHz and 16 kHz can be set for the servo control type.

Type	$I_{2N,PU}$ 4 kHz	$I_{2N,PU}$ 8 kHz	$I_{2N,PU}$ 16 kHz
SDS 5007A	4 A	3 A	2 A
SDS 5008A	2.3 A	1.7 A	1.2 A
SDS 5015A	4.5 A	3.4 A	2.2 A
SDS 5040A	10 A	6 A	3.3 A
SDS 5075A	16 A	10 A	5.7 A
SDS 5110A	22 A	14 A	8.1 A
SDS 5150A	32 A	20 A	11.4 A
SDS 5220A	44 A	30 A	18.3 A
SDS 5370A	70 A	50 A	31.8 A
SDS 5450A	85 A	60 A	37.8 A

Tab. 27: Nominal output current $I_{2N,PU}$ dependent on the clock frequency

5.2.6 Dimensions

The dimensions of the available SDS 5000 sizes can be found in the following chapters.

5.2.6.1 Dimensions: sizes 0 to 2

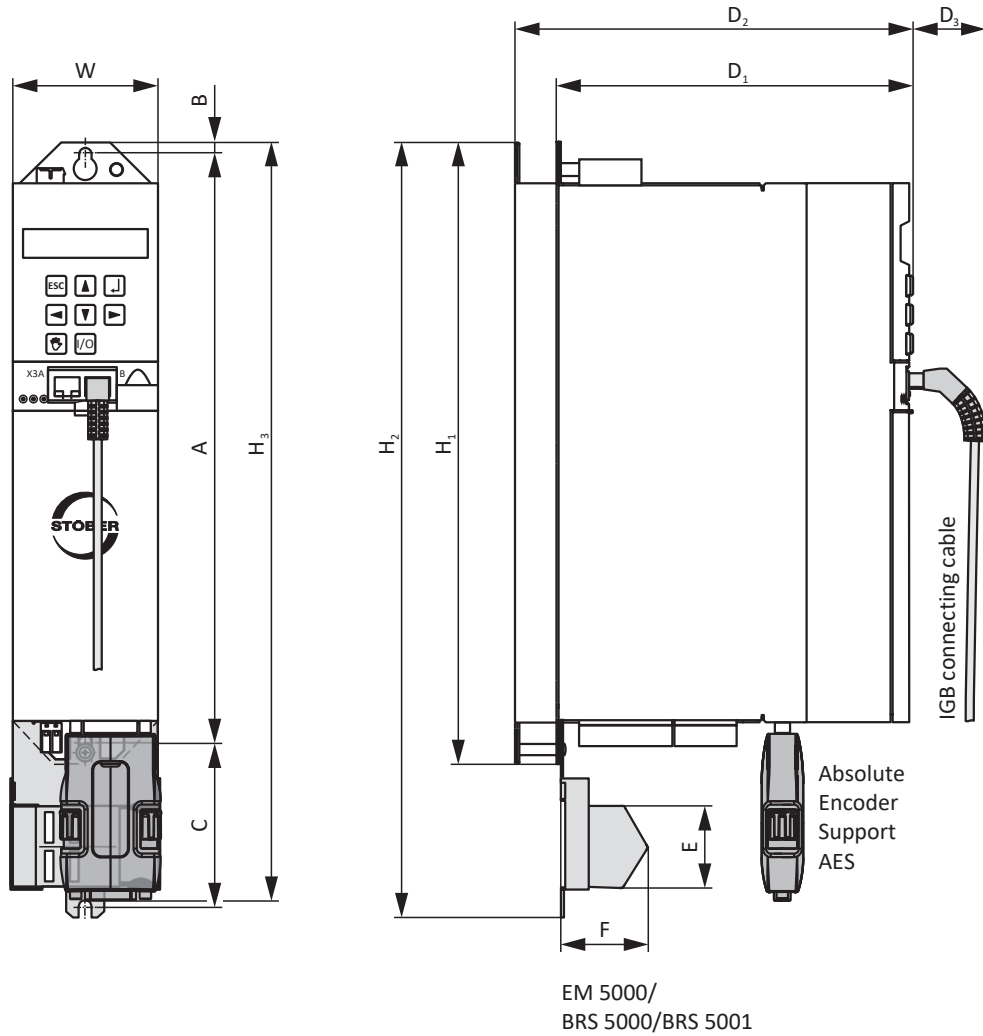

Fig. 1: SDS 5000 dimensional drawing, sizes 0 to 2

Dimensions [mm]			Size 0	Size 1	Size 2
Inverter	Height	H ₁	300		
		H ₂	360 ¹⁷ / 373 ¹⁸		
		H ₃ ¹⁹	365		
	Width	W	70	105	
	Depth	D ₁	175	260	260
D ₂ ²⁰		193	278	278	
D ₃		40			
EMC shroud	Height	E	37.5 ²¹ / 44 ²²		
	Depth	F	40		
Fastening holes	Vertical distance to the upper edge	B	6		
	Vertical distance	A	283+2		
	Vertical distance	C ²³	79		

Tab. 28: SDS 5000 dimensions, sizes 0 to 2 [mm]

¹⁷ H₂ = Height incl. EM 5000 EMC shroud

¹⁸ H₂ = Height incl. BRS 5001 brake module

¹⁹ H₃ = Height incl. AES

²⁰ D₂ = Depth incl. RB 5000 braking resistor

²¹ E = Height of EM 5000 EMC shroud

²² E = Height of BRS 5001 brake module

²³ C = Vertical distance with BRS 5001 brake module

5.2.6.2 Dimensions: size 3

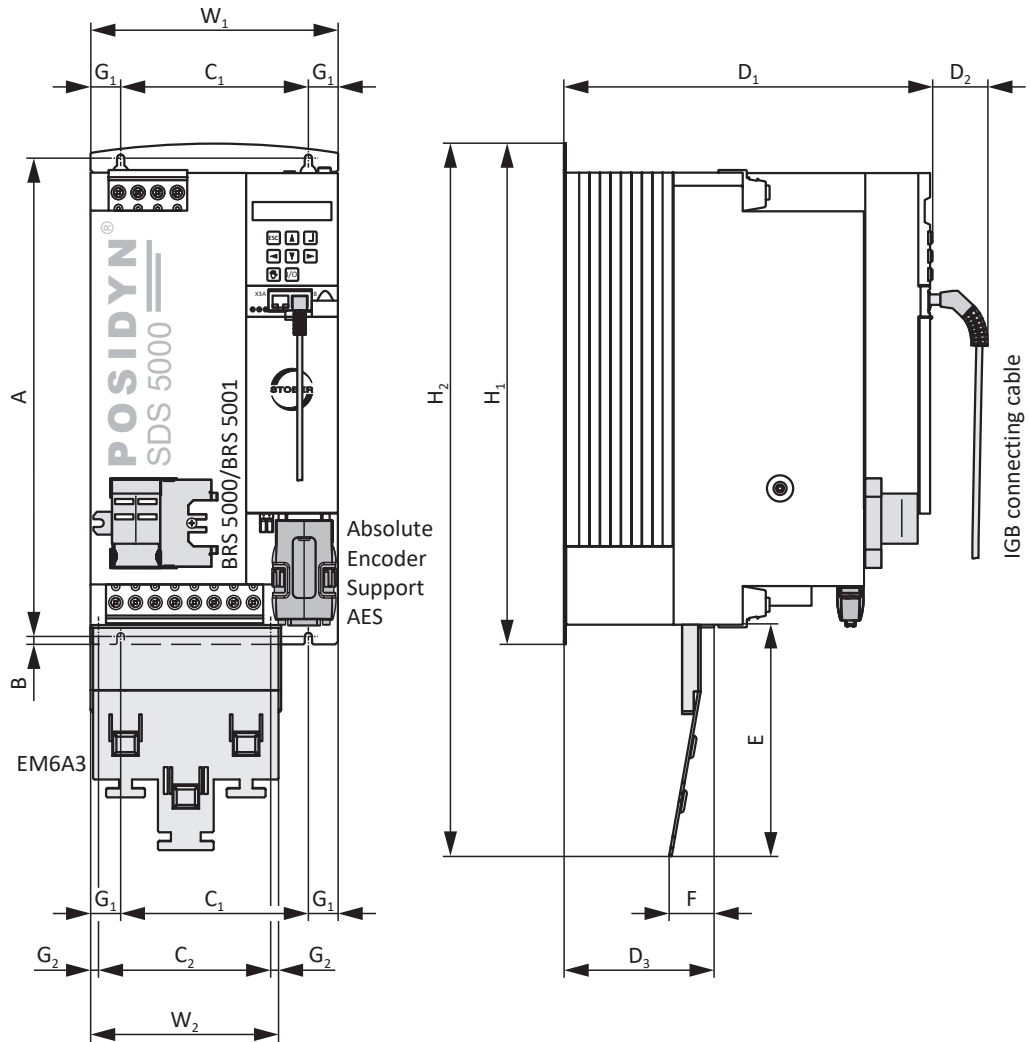

Fig. 2: SDS 5000 dimensional drawing, size 3

Dimensions [mm]			Size 3
Inverter	Height	H ₁	382.5
		H ₂ ²⁴	540
	Width	W ₁	194
	Depth	D ₁	276
EMC shroud	Height	D ₂	40
		E	174
	Width	W ₂	147
	Depth	F	34
Fastening holes	Depth	D ₃	113
	Vertical distance	A	365+2
	Vertical distance to the bottom edge	B	6
	Horizontal distance	C ₁ ²⁵	150+0.2/-0.2
	Horizontal distance to the side edge	G ₁ ²⁶	20
	Horizontal distance	C ₂ ²⁷	132
	Horizontal distance to the side edge	G ₂ ²⁸	7.5

Tab. 29: SDS 5000 dimensions, size 3 [mm]

²⁴ H₂ = Height incl. EM6A3 EMC shroud

²⁵ C₁ = Horizontal distance of the fastening holes of the inverter

²⁶ G₁ = Horizontal distance to the side edge of the inverter

²⁷ C₂ = Horizontal distance of the fastening holes of the EM6A3 EMC shroud

²⁸ G₂ = Horizontal distance to the side edge of the EM6A3 EMC shroud

5.2.7 Minimum clearances

The specified dimensions refer to the outside edges of the inverter.

Minimum clearance	Above	Below	On the side
Size 0 – Size 2	100	100	5
... with EMC shroud or brake module	100	120	5
Size 3	100	100	5
... with EMC shroud	100	220	5

Tab. 30: Minimum clearances [mm]

5.3 Inverter/motor combination

An explanation of the symbols used for formulas can be found in Chapter [▶ 9.1](#).

EZ synchronous servo motor ($n_N = 2000$ rpm) – SDS 5000

						5007A	5008A	5015A	5040A	5075A	5110A	5150A	5220A	5370A	5450A
						$I_{2N,PU}$ [A] ($f_{PWM,PU} = 8$ kHz)									
	K_{EM} [V/1000 rpm]	M_N [Nm]	I_N [A]	M_0 [Nm]	I_0 [A]	3	1.7	3.4	6	10	14	20	30	50	60

IC 410 convection cooling

						$I_{2N,PU} / I_0$										
EZ805U	142	43.7	25.9	66.1	37.9										1.3	1.6

IC 416 forced ventilation

						$I_{2N,PU} / I_0$										
EZ805B	142	77.2	45.2	94	53.9											1.1

EZ synchronous servo motor ($n_N = 3000$ rpm) – SDS 5000

						5007A	5008A	5015A	5040A	5075A	5110A	5150A	5220A	5370A	5450A
						$I_{2N,PU}$ [A] ($f_{PWM,PU} = 8$ kHz)									
	K_{EM} [V/1000 rpm]	M_N [Nm]	I_N [A]	M_0 [Nm]	I_0 [A]	3	1.7	3.4	6	10	14	20	30	50	60

IC 410 convection cooling

						$I_{2N,PU} / I_0$										
EZ301U	40	0.93	1.99	0.95	2.02	1.5		1.7								
EZ302U	86	1.59	1.6	1.68	1.67		1.0	2.0								
EZ303U	109	2.07	1.63	2.19	1.71		1.0	2.0								
EZ401U	96	2.8	2.74	3	2.88			1.2								
EZ402U	94	4.7	4.4	5.2	4.8				1.3							
EZ404U	116	6.9	5.8	8.6	6.6					1.5						
EZ501U	97	4.3	3.74	4.7	4				1.5							
EZ502U	121	7.4	5.46	8	5.76				1.0	1.7						
EZ503U	119	9.7	6.9	11.1	7.67					1.3	1.8					
EZ505U	141	13.5	8.8	16	10					1.0	1.4	2.0				
EZ701U	95	7.4	7.2	8.3	8					1.3	1.8					
EZ702U	133	12	8.2	14.4	9.6					1.0	1.5					
EZ703U	122	16.5	11.4	20.8	14						1.0	1.4				
EZ705U	140	21.3	14.2	30.2	19.5							1.0	1.5			
EZ802U	136	22.3	13.9	37.1	22.3								1.3			
EZ803U	131	26.6	17.7	48.2	31.1									1.6	1.9	

IC 416 forced ventilation

						$I_{2N,PU} / I_0$										
EZ401B	96	3.4	3.4	3.7	3.6				1.7							
EZ402B	94	5.9	5.5	6.3	5.8				1.0	1.7						
EZ404B	116	10.2	8.2	11.2	8.7					1.1	1.6					
EZ501B	97	5.4	4.7	5.8	5				1.2	2.0						
EZ502B	121	10.3	7.8	11.2	8.16					1.2	1.7					
EZ503B	119	14.4	10.9	15.9	11.8						1.2	1.7				
EZ505B	141	20.2	13.7	23.4	14.7						1.0	1.4				
EZ701B	95	9.7	9.5	10.5	10					1.0	1.4	2.0				
EZ702B	133	16.6	11.8	19.3	12.9						1.1	1.6				
EZ703B	122	24	18.2	28	20							1.0	1.5			
EZ705B	140	33.8	22.9	41.8	26.5								1.1	1.9		
EZ802B	136	34.3	26.5	47.9	28.9								1.0	1.7		
EZ803B	131	49	35.9	66.7	42.3									1.2	1.4	

EZ synchronous servo motor (n_N = 4500 rpm) – SDS 5000

						5007A	5008A	5015A	5040A	5075A	5110A	5150A	5220A	5370A	5450A
						$I_{2N,PU}$ [A] ($f_{PWM,PU} = 8$ kHz)									
K_{EM} [V/1000 rpm]	M_N [Nm]	I_N [A]	M_0 [Nm]	I_0 [A]		3	1.7	3.4	6	10	14	20	30	50	60

IC 410 convection cooling						$I_{2N,PU} / I_0$										
EZ505U	103	9.5	8.94	15.3	13.4						1.0	1.5				
EZ703U	99	12.1	11.5	20	17.8							1.1	1.7			
EZ705U	106	16.4	14.8	30	25.2								1.2	2.0		
EZ802U	90	10.5	11.2	34.5	33.3									1.5	1.8	

IC 416 forced ventilation						$I_{2N,PU} / I_0$										
EZ505B	103	16.4	16.4	22	19.4							1.0	1.5			
EZ703B	99	19.8	20.3	27.2	24.2								1.2			
EZ705B	106	27.7	25.4	39.4	32.8									1.5	1.8	
EZ802B	90	30.6	30.5	47.4	45.1									1.1	1.3	

EZ synchronous servo motor (n_N = 6000 rpm) – SDS 5000

						5007A	5008A	5015A	5040A	5075A	5110A	5150A	5220A	5370A	5450A
						$I_{2N,PU}$ [A] ($f_{PWM,PU} = 8$ kHz)									
K_{EM} [V/1000 rpm]	M_N [Nm]	I_N [A]	M_0 [Nm]	I_0 [A]		3	1.7	3.4	6	10	14	20	30	50	60

IC 410 convection cooling						$I_{2N,PU} / I_0$										
EZ202U	40	0.44	1.07	0.48	1.12		1.5									
EZ203U	40	0.64	1.53	0.73	1.65	1.8	1.0	2.1								
EZ301U	40	0.89	1.93	0.95	2.02			1.7								
EZ302U	42	1.5	3.18	1.68	3.48				1.7							
EZ303U	55	1.96	3.17	2.25	3.55				1.7							
EZ401U	47	2.3	4.56	2.8	5.36				1.1	1.9						
EZ402U	60	3.5	5.65	4.9	7.43					1.3	1.9					
EZ404U	78	5.8	7.18	8.4	9.78					1.0	1.4	2.0				
EZ501U	68	3.4	4.77	4.4	5.8			1.0	1.7	2.4						
EZ502U	72	5.2	7.35	7.8	9.8					1.0	1.4	2.0				
EZ503U	84	6.2	7.64	10.6	11.6						1.2	1.7				
EZ701U	76	5.2	6.68	7.9	9.38					1.1	1.5					
EZ702U	82	7.2	8.96	14.3	16.5							1.2	1.8			

IC 416 forced ventilation						$I_{2N,PU} / I_0$										
EZ401B	47	2.9	5.62	3.5	6.83					1.5	2.0					
EZ402B	60	5.1	7.88	6.4	9.34					1.1	1.5					
EZ404B	78	8	9.98	10.5	12						1.2	1.7				
EZ501B	68	4.5	6.7	5.7	7.5					1.3	1.9					
EZ502B	72	8.2	11.4	10.5	13.4						1.0	1.5				
EZ503B	84	10.4	13.5	14.8	15.9							1.3	1.9			
EZ701B	76	7.5	10.6	10.2	12.4						1.1	1.6				
EZ702B	82	12.5	16.7	19.3	22.1								1.4			

5.4 Accessories

You can find information about the available accessories in the following chapters.

5.4.1 Safety technology

ASP 5001 – Safe Torque Off

Information

The drive controller is delivered in the standard design without safety technology. If you want a drive controller with integrated safety technology, you must order it together with the drive controller. The safety modules are an integrated part of the drive controller and must not be modified.

Available with the standard design.



Option module for implementation of integrated safety function Safe Torque Off (STO).

5.4.2 Communication

IGB connecting cable



Cable for connecting the interface X3A or X3B on the inverter front for IGB, CAT5e, magenta, connector angled at 45°.

The following versions are available:

ID No. 49855: 0.4 m.

ID No. 49856: 2 m.

PC connecting cables



ID No. 49857

Cable for connecting the X3A or X3B interface with the PC, CAT5e, blue, 5 m.

USB 2.0 Ethernet adapter



ID No. 49940

Adapter for connecting Ethernet to a USB port.

CANopen DS-301 CAN 5000 communication module



ID No. 44574

Accessory part for connecting CAN bus.

PROFIBUS DP-V1 DP 5000 communication module



ID No. 44575
Accessory module for connecting PROFIBUS DP-V1.

EtherCAT ECS 5000 communication module



ID No. 49014
Accessory part for connecting EtherCAT (CANopen over EtherCAT).

EtherCAT cables



Ethernet patch cable, CAT5e, yellow.
The following designs are available:
ID No. 49313: Length approx. 0.25 m.
ID No. 49314: Length approx. 0.5 m.

PROFINET PN 5000 communication module



ID No. 53893
Accessory part for connecting PROFINET.

5.4.3 Terminal module

SEA 5001 standard terminal module



ID No. 49576

Terminals:

- 2 analog inputs
- 2 analog outputs
- 5 digital inputs
- 2 digital outputs

XEA 5001 extended terminal module



ID No. 49015

Terminals:

- 3 analog inputs
- 2 analog outputs
- 13 digital inputs
- 10 digital outputs

Encoder / interfaces:

- TTL incremental encoder (simulation and evaluation)
- Pulse/direction interface (simulation and evaluation)
- SSI encoder (simulation and evaluation)

X120 SSI/TTL connection cable



ID No. 49482

Cable for connecting the X120 TTL interface on the SD6 drive controller (on terminal module RI6 or XI6) with the X301 interface on the LA6 adapter box in order to transfer Hall sensor signals. 0.3 m.

REA 5001 resolver terminal module

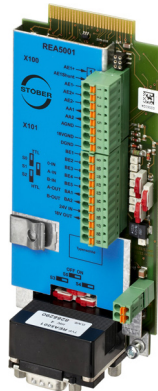

ID No. 49854

Terminals:

- 2 analog inputs
- 2 analog outputs
- 5 binary inputs
- 2 binary outputs

Encoder / interfaces:

- Resolver
- EnDat 2.1 sin/cos encoders
- TTL incremental encoder (simulation and evaluation)
- SSI encoder (simulation and evaluation)
- Pulse/direction interface (simulation and evaluation)



Resolver cables that were connected to an POSIDYN SDS 4000 can be connected using the resolver adapter (9-pin to 15-pin) included in the scope of delivery to terminal X140 of REA 5001.

5.4.4 Braking resistor

In addition to the inverters, STÖBER offers braking resistors in different sizes and performance classes described below. For the selection, note the minimum permitted braking resistances specified in the technical data of the individual inverter types.

5.4.4.1 FZMU, FZZMU tubular fixed resistor

Type	FZMU 400×65			FZZMU 400×65		
	49010	55445	55446	53895	55447	55448
ID No.	49010	55445	55446	53895	55447	55448
SDS 5007A	X	—	—	—	—	—
SDS 5008A	X	—	—	—	—	—
SDS 5015A	X	—	—	—	—	—
SDS 5040A	(X)	—	—	X	—	—
SDS 5075A	(X)	—	—	X	—	—
SDS 5110A	(—)	X	—	(X)	X	—
SDS 5150A	(—)	X	—	(X)	X	—
SDS 5220A	(—)	(X)	X	(—)	(X)	X
SDS 5370A	(—)	(X)	X	(—)	(X)	X
SDS 5450A	(—)	(X)	X	(—)	(X)	X

Tab. 31: Assignment of FZMU, FZZMU braking resistor – SDS 5000 inverter

X	Recommended
(X)	Possible
(—)	Useful under certain conditions
—	Not possible

Properties

Specification	FZMU 400×65			FZZMU 400×65		
	49010	55445	55446	53895	55447	55448
ID No.	49010	55445	55446	53895	55447	55448
Type	Tubular fixed resistor			Tubular fixed resistor		
Resistance [Ω]	100 $\pm 10\%$	22 $\pm 10\%$	15 $\pm 10\%$	47 $\pm 10\%$	22 $\pm 10\%$	15 $\pm 10\%$
Thermal drift	$\pm 10\%$			$\pm 10\%$		
Power [W]	600			1200		
Therm. time const. τ_{th} [s]	40			40		
Pulse power for < 1 s [kW]	18			36		
U_{max} [V]	848			848		
Weight without packaging [g]	2200			4170		
Protection class	IP20			IP20		
Test symbols	cURus, CE, UKCA			cURus, CE, UKCA		

Tab. 32: FZMU, FZZMU specification

Dimensions

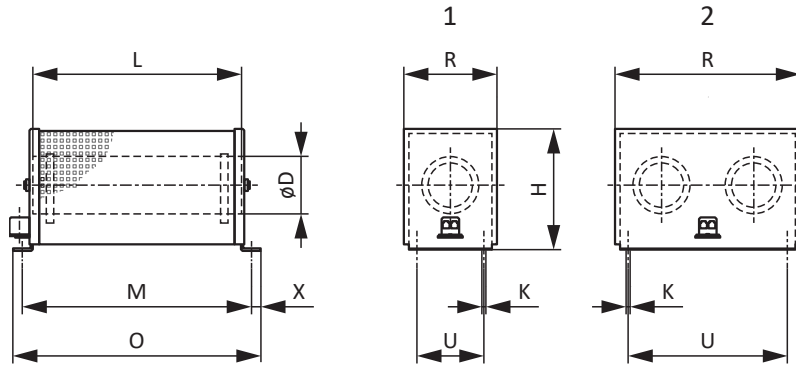

Fig. 3: FZMU (1), FZZMU (2) dimensional drawing

Dimension	FZMU 400×65			FZZMU 400×65		
	49010	55445	55446	53895	55447	55448
L x D	400 × 65			400 × 65		
H	120			120		
K	6.5 × 12			6.5 × 12		
M	430			426		
O	485			485		
R	92			185		
U	64			150		
X	10			10		

Tab. 33: FZMU, FZZMU dimensions [mm]

5.4.4.2 GVADU, GBADU flat resistor

Type	GVADU 210×20	GBADU 265×30	GBADU 405×30	GBADU 335×30	GBADU 265×30
ID No.	55441	55442	55499	55443	55444
SDS 5007A	X	X	X	—	—
SDS 5008A	X	X	X	—	—
SDS 5015A	X	X	X	—	—
SDS 5040A	(X)	(X)	(X)	X	—
SDS 5075A	(X)	(X)	(X)	X	—
SDS 5110A	(—)	(—)	(—)	(X)	X
SDS 5150A	(—)	(—)	(—)	(X)	X
SDS 5220A	(—)	(—)	(—)	(—)	(X)
SDS 5370A	(—)	(—)	(—)	(—)	(X)
SDS 5450A	(—)	(—)	(—)	(—)	(X)

Tab. 34: Assignment of GVADU, GBADU braking resistor – SDS 5000 inverters

X	Recommended
(X)	Possible
(—)	Useful under certain conditions
—	Not possible

Properties

Specification	GVADU 210×20	GBADU 265×30	GBADU 405×30	GBADU 335×30	GBADU 265×30
ID No.	55441	55442	55499	55443	55444
Type	Flat resistor				
Resistance [Ω]	100 \pm 10 %	100 \pm 10 %	100 \pm 10 %	47 \pm 10 %	22 \pm 10 %
Thermal drift	\pm 10 %	\pm 10 %	\pm 10 %	\pm 10 %	\pm 10 %
Power [W]	150	300	500	400	300
Therm. time const. τ_{th} [s]	60	60	60	60	60
Pulse power for < 1 s [kW]	3.3	6.6	11	8.8	6.6
U_{max} [V]	848	848	848	848	848
Cable design	Radox	FEP	FEP	FEP	FEP
Cable length [mm]	500	1500	500	1500	1500
Conductor cross-section [AWG]	18/19 (0.82 mm ²)	14/19 (1.9 mm ²)	14/19 (1.9 mm ²)	14/19 (1.9 mm ²)	14/19 (1.9 mm ²)
Weight without packaging [g]	300	930	1410	1200	930
Protection class	IP54	IP54	IP54	IP54	IP54
Test symbols	cURus, CE, UKCA				

Tab. 35: GVADU, GBADU specification

Dimensions

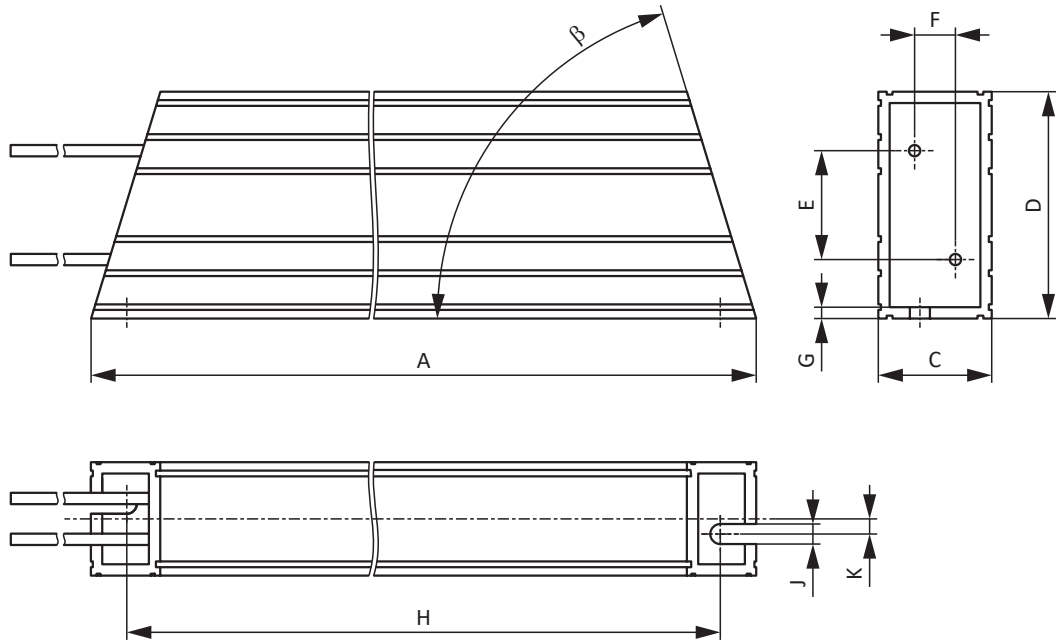

Fig. 4: GVADU, GBADU dimensional drawing

Dimension	GVADU 210×20	GBADU 265×30	GBADU 405×30	GBADU 335×30	GBADU 265×30
ID No.	55441	55442	55499	55443	55444
A	210	265	405	335	265
H	192	246	386	316	246
C	20	30	30	30	30
D	40	60	60	60	60
E	18.2	28.8	28.8	28.8	28.8
F	6.2	10.8	10.8	10.8	10.8
G	2	3	3	3	3
K	2.5	4	4	4	4
J	4.3	5.3	5.3	5.3	5.3
β	65°	73°	73°	73°	73°

Tab. 36: GVADU, GBADU dimensions [mm]

5.4.4.3 FGFKU steel-grid fixed resistor

Type	FGFKU 3100502	FGFKU 3100502	FGFKU 3111202	FGFKU 3121602
ID No.	55449	55450	55451	53897
SDS 5110A	X	—	—	—
SDS 5150A	X	—	—	—
SDS 5220A	(X)	X	X	X
SDS 5370A	(X)	X	X	X
SDS 5450A	(X)	X	X	X

Tab. 37: Assignment of FGFKU braking resistor – SDS 5000 inverter

X	Recommended
(X)	Possible
—	Not possible

Properties

Specification	FGFKU 3100502	FGFKU 3100502	FGFKU 3111202	FGFKU 3121602
ID No.	55449	55450	55451	53897
Type	Steel-grid fixed resistor			
Resistance [Ω]	22 \pm 10 %	15 \pm 10 %	15 \pm 10 %	15 \pm 10 %
Thermal drift	\pm 10 %	\pm 10 %	\pm 10 %	\pm 10 %
Power [W]	2500	2500	6000	8000
Therm. time const. τ_{th} [s]	30	30	20	20
Pulse power for < 1 s [kW]	50	50	120	160
U_{max} [V]	848	848	848	848
Weight without packaging [g]	7500	7500	12000	18000
Protection class	IP20	IP20	IP20	IP20
Test symbols	cURus, CE, UKCA			

Tab. 38: FGFKU specification

Dimensions

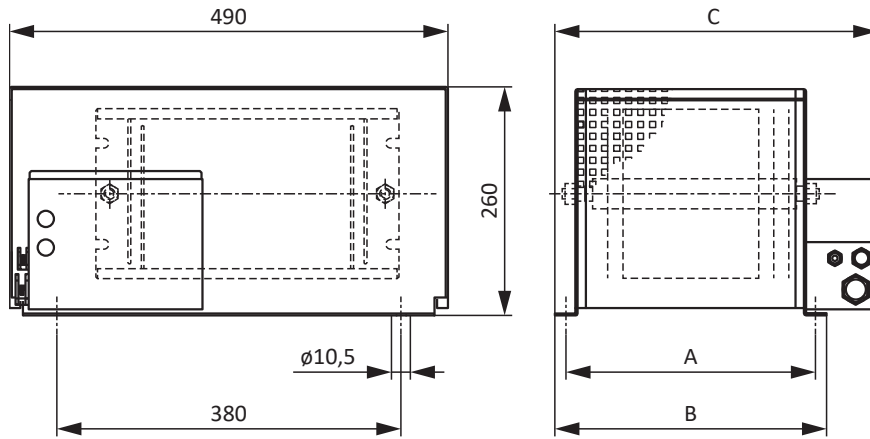

Fig. 5: FGFKU dimensional drawing

Dimension	FGFKU 3100502	FGFKU 3100502	FGFKU 3111202	FGFKU 3121602
ID No.	55449	55450	55451	53897
A	270	270	370	570
B	295	295	395	595
C	355	355	455	655

Tab. 39: FGFKU dimensions [mm]

5.4.4.4 RB 5000 rear section braking resistor

Type	RB 5022	RB 5047	RB 5100
ID No.	45618	44966	44965
SDS 5007A	—	—	X
SDS 5008A	—	—	X
SDS 5015A	—	—	X
SDS 5040A	—	X	(X)
SDS 5075A	—	X	(X)
SDS 5110A	X	—	—
SDS 5150A	X	—	—

Tab. 40: Assignment of RB 5000 braking resistor – SDS 5000 inverter

X	Recommended
(X)	Possible
—	Not possible

Properties

Specification	RB 5022	RB 5047	RB 5100
ID No.	45618	44966	44965
Resistance [Ω]	22 \pm 10 %	47 \pm 10 %	100 \pm 10 %
Thermal drift	\pm 10 %	\pm 10 %	\pm 10 %
Power [W]	100	60	60
Therm. time const. τ_{th} [s]	8	8	8
Pulse power for < 1 s [kW]	1.5	1.0	1.0
U_{max} [V]	800	800	800
Weight without packaging [g]	640	460	440
Cable design	Radox	Radox	Radox
Cable length [mm]	250	250	250
Conductor cross-section [AWG]	18/19	18/19	18/19
	(0.82 mm ²)	(0.82 mm ²)	(0.82 mm ²)
Maximum torque of M5 threaded bolts [Nm]	5	5	5
Protection class	IP40	IP40	IP40
Test symbols	cURus, CE, UKCA	cURus, CE, UKCA	cURus, CE, UKCA

Tab. 41: RB 5000 specification

Dimensions

Dimension	RB 5022	RB 5047	RB 5100
ID No.	45618	44966	44965
Height	300	300	300
Width	94	62	62
Depth	18	18	18
Drilling diagram corresponds to size	Size 2	Size 1	Size 0 and Size 1

Tab. 42: RB 5000 dimensions [mm]

5.4.5 Choke

Technical specifications for suitable chokes can be found in the following chapters.

5.4.5.1 TEP output choke

Output chokes are required for connecting size 0 to 2 drive controllers from a cable length > 50 m in order to reduce interference pulses and protect the drive system.

Information

The following technical data only applies to a rotating magnetic field frequency of 200 Hz. For example, this rotating magnetic field frequency is achieved with a motor with 4 pole pairs and a nominal speed of 3000 rpm. Always observe the specified derating for higher rotating magnetic field frequencies. Also observe the relationship with the clock frequency.

Properties

Specification	TEP3720-0ES41	TEP3820-0CS41	TEP4020-0RS41
ID No.	53188	53189	53190
Voltage range	3 × 0 to 480 V _{AC}		
Frequency range	0 – 200 Hz		
Nominal current I _{N,MF} at 4 kHz	4 A	17.5 A	38 A
Nominal current I _{N,MF} at 8 kHz	3.3 A	15.2 A	30.4 A
Max. permitted motor cable length with output choke	100 m		
Max. surrounding temperature $\vartheta_{amb,max}$	40 °C		
Protection class	IP00		
Winding losses	11 W	29 W	61 W
Iron losses	25 W	16 W	33 W
Connection	Screw terminal		
Max. conductor cross-section	10 mm ²		
UL Recognized Component (CAN; USA)	Yes		
Test symbols	cURus, CE		

Tab. 43: TEP specification

Dimensions

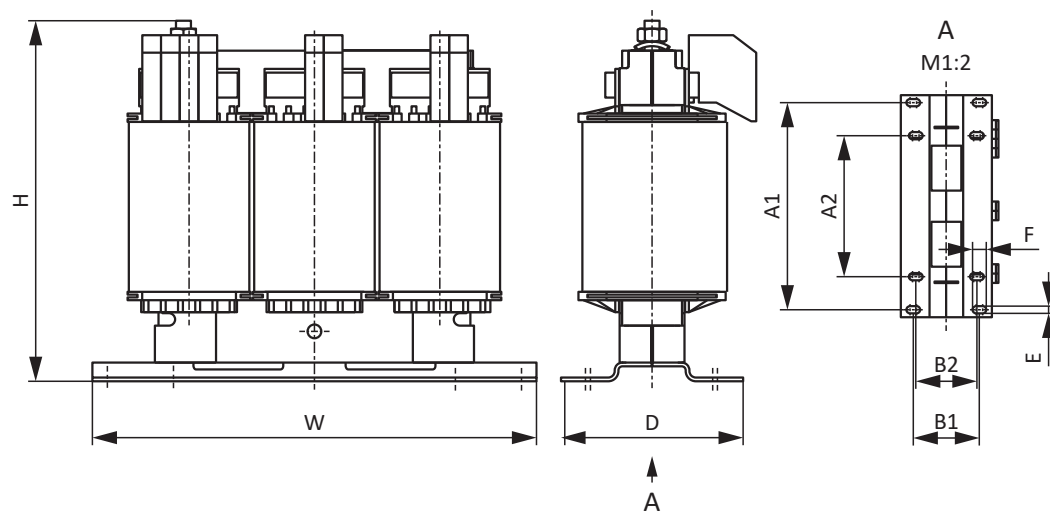

Fig. 6: TEP dimensional drawing

Dimension	TEP3720-0ES41	TEP3820-0CS41	TEP4020-0RS41
Height H [mm]	Max. 153	Max. 153	Max. 180
Width W [mm]	178	178	219
Depth D [mm]	73	88	119
Vertical distance – Fastening holes A1 [mm]	166	166	201
Vertical distance – Fastening holes A2 [mm]	113	113	136
Horizontal distance – Fastening holes B1 [mm]	53	68	89
Horizontal distance – Fastening holes B2 [mm]	49	64	76
Drill holes – Depth E [mm]	5.8	5.8	7
Drill holes – Width F [mm]	11	11	13
Screw connection – M	M5	M5	M6
Weight without packaging [g]	2900	5900	8800

Tab. 44: TEP dimensions and weight

5.4.6 Brake module and EMC shroud

BRS 5001 brake module



ID No. 56519

Brake module for inverters of the SDS 5000 series.

Accessory part for direct control of up to two brakes ($24 V_{DC}$) and (for inverters up to size 2) for connecting to the shield of the power cable.

Can be attached to the basic housing.

Including connection cable for basic device and shield connection terminal.

EM 5000 EMC shroud



ID No. 44959

EMC shroud for servo inverters of generation 5.

Accessory part for shield connection of the power cable for inverters up to size 2.

Can be attached to the basic housing.

Including shield connection terminal.

EMC shroud EM6A3



ID No. 56521

EMC shroud for drive controllers of the MDS 5000, SDS 5000 and SD6 series.

Accessory part for shield connection of the power cable for drive controllers up to size 3.

Can be attached to the basic housing.

Including shield connection terminal.

If necessary you can also connect the cable shield of the braking resistor and DC link connection to the shroud.

5.4.7 Axis switcher

POSIswitch AX 5000 4-way axis switcher



ID No. 49578

Axis switcher for MDS 5000 and SDS 5000 series inverters.

Enables the operation of up to four synchronous servo motors on one inverter.

LA6 / AX 5000 connection cable



Cable to connect inverter and POSISwitch AX 5000 axis switcher.

The following versions are available:

ID No. 45405: 0.5 m.

ID No. 45386: 2.5 m.

5.4.8 Encoder battery module

Absolute Encoder Support (AES)

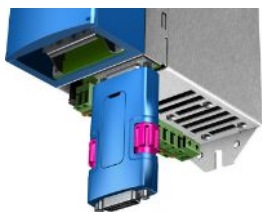

ID No. 55452

Battery module for buffering the supply voltage when using the EnDat 2.2 digital inductive encoder with battery-buffered multi-turn stage, for example EBI1135 or EBI135.

A battery is included.

AES replacement battery



ID No. 55453

Replacement battery for AES battery module.

5.4.9 Removable data storage

Paramodul removable data storage

Included in the standard version.



ID No. 55464

Memory module for configuration and parameters.

5.5 Further information

5.5.1 Directives and standards

The following European directives and standards are relevant for inverters:

- Machinery Directive 2006/42/EC
- Low Voltage Directive 2014/35/EU
- EMC Directive 2014/30/EU
- EN 61326-3-1:2008
- EN 61800-3:2012-09 and 1:2014-02
- EN 61800-5-1:2008-04 and 1:2010-04
- EN 61800-5-2:2016-04
- EN 50178:1997

5.5.2 Symbols, marks and test symbols



Grounding symbol

Grounding symbol in accordance with IEC 60417, symbol 5019.



RoHS lead-free mark

Marking in accordance with RoHS directive 2011-65-EU.



CE mark

Manufacturer's self declaration: The product meets the requirements of EU directives.



UKCA test symbol

Manufacturer's self declaration: The product meets the requirements of UK directives.



UL test symbol

This product is listed by UL for the United States and Canada. Representative samples of this product have been evaluated by UL and meet the requirements of applicable standards.



UL recognized component mark

This component or material is recognized by UL. Representative samples of this product have been evaluated by UL and meet applicable requirements.

5.5.3 Additional documentation

Additional documentation related to the product can be found at

<http://www.stoeber.de/en/downloads/>

Enter the ID of the documentation in the Search field.

Documentation	ID
Configuration manual for POSIDYN SDS 5000 servo inverters	442277

6 Connection method

Table of contents

6.1	Overview	170
6.2	Conventions for cables	171
6.3	Power cables	171
6.3.1	Motor assignment	172
6.3.2	Connection description	173
6.4	Encoder cables	176
6.4.1	EnDat 2.1/2.2 digital encoders	176
6.4.2	EnDat 2.1 sin/cos encoders	179
6.4.3	Resolver	181
6.5	One Cable Solution EnDat 3	182
6.5.1	Motor assignment	183
6.5.2	Connection description	184
6.6	Additional documentation	185

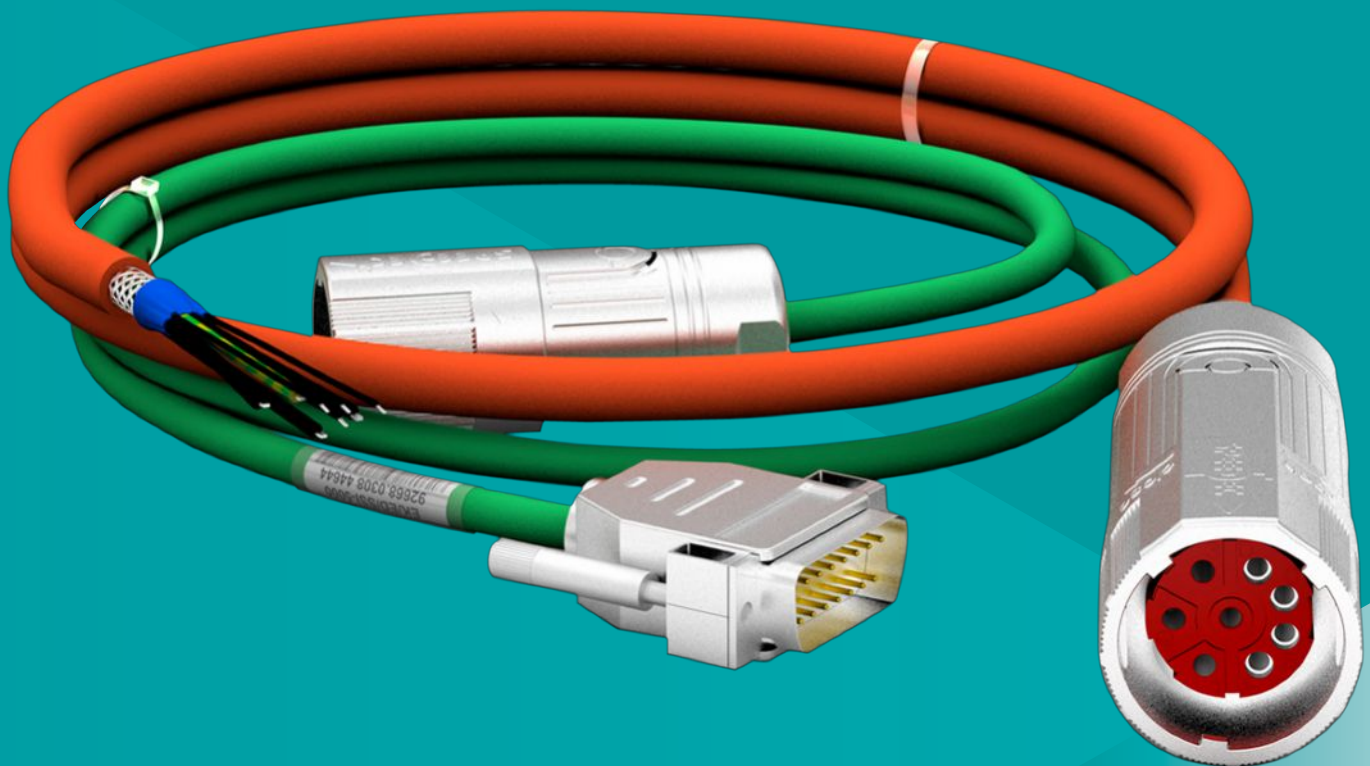

6 Connection method

6.1 Overview

Coordinated connection methods for STOBBER drive controllers

Features

- Torsional stress $\pm 30^\circ/\text{m}$
- Bending resistance
- Oil resistance
- Chemical resistance

A drive controller, cable and motor that are not coordinated with one another can lead to impermissibly high voltage peaks in the drive system, which may cause damage to the motor. The legal requirements of (EMC) Directive 2014/30/EU must also be observed.

Combining STOBBER motors, STOBBER cables and STOBBER drive controllers enables you to comply with these legal requirements.

STOBBER offers a range of cables to match. Cables are available in different lengths and are ready-made on both ends.

Using unsuitable connection cables may void any claims made under the warranty.

6.2 Conventions for cables

In the cable connection descriptions, core colors are shortened and used as follows.

Cable colors

BK:	BLACK	PK:	PINK
BN:	BROWN	RD:	RED
BU:	BLUE	VT:	VIOLET
GN:	GREEN	WH:	WHITE
GY:	GRAY	YE:	YELLOW
OG:	ORANGE		

Formatting conventions

Two-colored core:	WHYE	WHITEYELLOW (white and yellow)
Single-colored core:	BK/BN	BLACK/BROWN (black or brown)

6.3 Power cables

STOBER synchronous servo motors are equipped with plug connectors as standard.

STOBER provides suitable cables in various lengths, conductor cross-sections and connector sizes.

The cables are available ready-made in the lengths 2.5 m, 5.0 m, 7.5 m, 10.0 m, 12.5 m, 15.0 m, 18.0 m, 20.0 m, 25.0 m, 30.0 m.

Other lengths on request.

6.3.1 Motor assignment

STOBER offers cables with a minimum cross-section for the motors as standard. Depending on the application, however, larger conductor cross-sections may be required. For this reason, take into account the following points in addition for dimensioning the cable:

- Stall current I_0 of the motor
- Permitted current carrying capacity of the conductors
- Cable length
- Terminal specifications of the drive controller or output choke
- Connector size of the motor

EZ motors – IC 410 convection cooling

	n_N 2000 rpm			n_N 3000 rpm			n_N 4500 rpm			n_N 6000 rpm		
	K_{EM} V/1000 rpm	Plug con. size	Minimum cross-section mm ²	K_{EM} V/1000 rpm	Plug con. size	Minimum cross-section mm ²	K_{EM} V/1000 rpm	Plug con. size	Minimum cross-section mm ²	K_{EM} V/1000 rpm	Plug con. size	Minimum cross-section mm ²
EZ202U	—	—	—	—	—	—	—	—	—	40	con.15	1.0
EZ203U	—	—	—	—	—	—	—	—	—	40	con.15	1.0
EZ301U	—	—	—	40	con.15	1.0	—	—	—	40	con.15	1.0
EZ302U	—	—	—	86	con.15	1.0	—	—	—	42	con.15	1.0
EZ303U	—	—	—	109	con.15	1.0	—	—	—	55	con.15	1.0
EZ401U	—	—	—	96	con.23	1.0 / 1.5	—	—	—	47	con.23	1.0 / 1.5
EZ402U	—	—	—	94	con.23	1.0 / 1.5	—	—	—	60	con.23	1.0 / 1.5
EZ404U	—	—	—	116	con.23	1.0 / 1.5	—	—	—	78	con.23	1.0 / 1.5
EZ501U	—	—	—	97	con.23	1.0 / 1.5	—	—	—	68	con.23	1.0 / 1.5
EZ502U	—	—	—	121	con.23	1.0 / 1.5	—	—	—	72	con.23	1.0 / 1.5
EZ503U	—	—	—	119	con.23	1.0 / 1.5	—	—	—	84	con.23	1.0 / 1.5
EZ505U	—	—	—	141	con.23	1.0 / 1.5	103	con.23	1.5	—	—	—
EZ701U	—	—	—	95	con.23	1.0 / 1.5	—	—	—	76	con.23	1.0 / 1.5
EZ702U	—	—	—	133	con.23	1.0 / 1.5	—	—	—	82	con.23	2.5
EZ703U	—	—	—	122	con.23	1.5	99	con.23	2.5	—	—	—
EZ705U	—	—	—	140	con.40	2.5	106	con.40	4.0	—	—	—
EZ802U	—	—	—	136	con.40	4.0	90	con.40	4.0 / 6.0	—	—	—
EZ803U	—	—	—	131	con.40	6.0	—	—	—	—	—	—
EZ805U	142	con.40	10.0	—	—	—	—	—	—	—	—	—

Tab. 1: Plug connector size and minimum cross-section, EZ synchronous servo motors with convection cooling

Minimum cross-section specification: The smaller cross-section is available from Q2/22 and applies to cable lengths up to max. 12.5 m.

EZ motors – IC 416 forced ventilation

	n_N 2000 rpm			n_N 3000 rpm			n_N 4500 rpm			n_N 6000 rpm		
	K_{EM} V/1000 rpm	Plug con. size	Minimum cross-section mm ²	K_{EM} V/1000 rpm	Plug con. size	Minimum cross-section mm ²	K_{EM} V/1000 rpm	Plug con. size	Minimum cross-section mm ²	K_{EM} V/1000 rpm	Plug con. size	Minimum cross-section mm ²
EZ401B	—	—	—	96	con.23	1.0 / 1.5	—	—	—	47	con.23	1.0 / 1.5
EZ402B	—	—	—	94	con.23	1.0 / 1.5	—	—	—	60	con.23	1.0 / 1.5
EZ404B	—	—	—	116	con.23	1.0 / 1.5	—	—	—	78	con.23	1.0 / 1.5
EZ501B	—	—	—	97	con.23	1.0 / 1.5	—	—	—	68	con.23	1.0 / 1.5
EZ502B	—	—	—	121	con.23	1.0 / 1.5	—	—	—	72	con.23	1.5
EZ503B	—	—	—	119	con.23	1.0 / 1.5	—	—	—	84	con.23	2.5
EZ505B	—	—	—	141	con.23	1.5	103	con.23	2.5	—	—	—
EZ701B	—	—	—	95	con.23	1.0 / 1.5	—	—	—	76	con.23	1.0 / 1.5
EZ702B	—	—	—	133	con.23	1.0 / 1.5	—	—	—	82	con.23	2.5 / 4.0
EZ703B	—	—	—	122	con.23	2.5	99	con.23	4.0	—	—	—
EZ705B	—	—	—	140	con.40	4.0	106	con.40	6.0	—	—	—
EZ802B	—	—	—	136	con.40	4.0 / 6.0	90	con.40	10.0	—	—	—
EZ803B	—	—	—	131	con.40	10.0	—	—	—	—	—	—
EZ805B	142	con.40	10.0	—	—	—	—	—	—	—	—	—

Tab. 2: Plug connector size and minimum cross-section, EZ synchronous servo motors with forced ventilation

Minimum cross-section specification: The smaller cross-section is available from Q2/22 and applies to cable lengths up to max. 12.5 m.

6.3.2 Connection description

Depending on the size of the motor plug connector, power cables are available in the following designs:

- Quick lock for con.15
- speedtec quick lock for con.23 and con.40

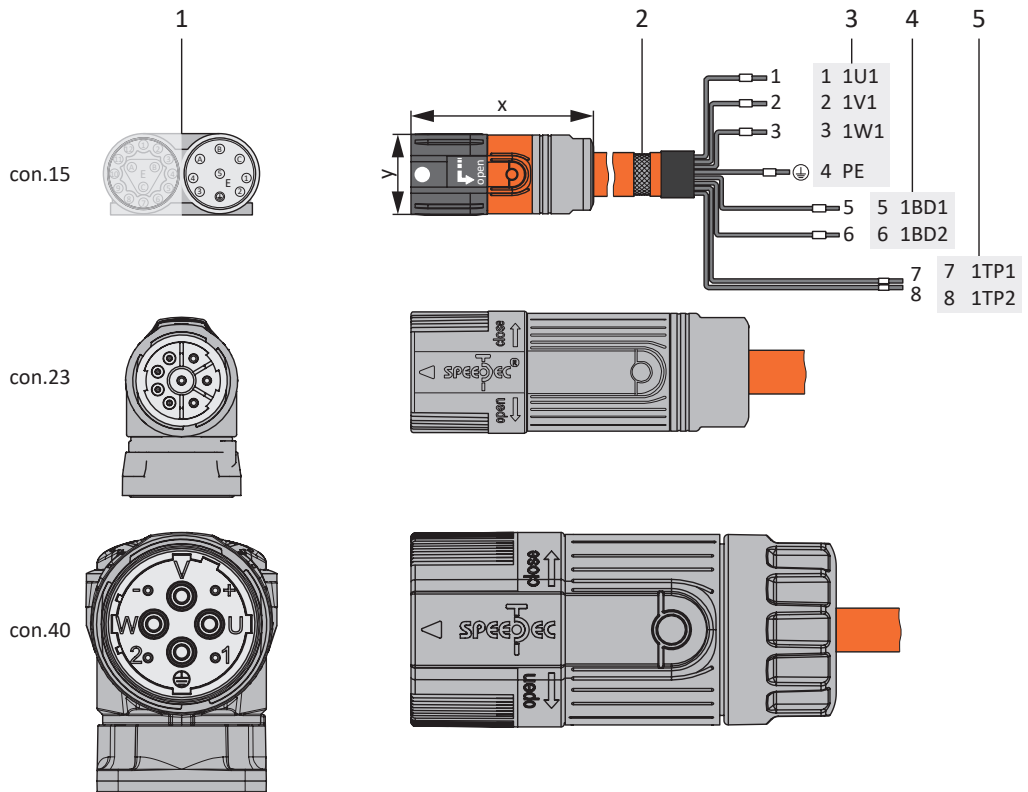

- 1 Plug connectors
- 2 STOBER power cable, cable shield
- 3 Connection to terminal X20, motor
- 4 Connection of terminal X2/X5, brake
- 5 Connection to terminal X2, temperature sensor



Information

The design of the cable shield connection on the controller side depends on the drive controller series.

Connection	Size 0 to 2	Size 3
Without output choke	50 m, shielded	100 m, shielded
With output choke	100 m, shielded	—

Tab. 3: Maximum cable length of the power cable [m]

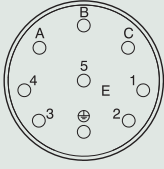
Power cables – con.15 plug connector

Motor connection diagram	Motor (1)			Cable (2)	Drive controller (3) – (5)		
	Pin	Designation	Int. motor Core color	Core No./ Core color	Pin X20	Pin X2/X5	Pin X2
	A	1U1	BK	1	1	—	—
	B	1V1	BU	2	2	—	—
	C	1W1	RD	3	3	—	—
	1	1TP1	BK/RD ^{a)}	7	—	—	7
	2	1TP2	WH ^{a)}	8	—	—	8
	3	1BD1	RD	5	—	5	—
	4	1BD2	BK	6	—	6	—
	5	—	—	—	—	—	—
		PE	GNYE	GNYE	4	—	—
	Housing	Shield	—	—	Shield contact	—	—



Tab. 4: con.15 power cable pin assignment

a) Color depends on the type of temperature sensor (PTC/Pt1000), which is specified on the motor name-plate.

Length x [mm]	Diameter y [mm]
42	18.7

Tab. 5: con.15 connector dimensions

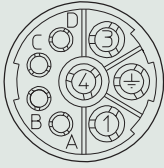
Power cables – con.23 plug connector

Motor connection diagram	Motor (1)			Cable (2)	Drive controller (3) – (5)		
	Pin	Designation	Int. motor Core color	Core No./ Core color	Pin X20	Pin X2/X5	Pin X2
	1	1U1	BK	1	1	—	—
	3	1V1	BU	2	2	—	—
	4	1W1	RD	3	3	—	—
	A	1BD1	RD	5	—	5	—
	B	1BD2	BK	6	—	6	—
	C	1TP1	BK/RD ^{a)}	7	—	—	7
	D	1TP2	WH ^{a)}	8	—	—	8
		PE	GNYE	GNYE	4	—	—
	Housing	Shield	—	—	Shield contact	—	—

Tab. 6: con.23 power cable pin assignment

a) Color depends on the type of temperature sensor (PTC/Pt1000), which is specified on the motor name-plate.

Length x [mm]	Diameter y [mm]
78	26

Tab. 7: con.23 connector dimensions

Power cables – con.40 plug connector

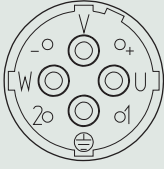
Motor connection diagram	Motor (1)			Cable (2)	Drive controller (3) – (5)		
	Pin	Designation	Int. motor Core color	Core No./ Core color	Pin X20	Pin X2/X5	Pin X2
	U	1U1	BK	1	1	—	—
	V	1V1	BU	2	2	—	—
	W	1W1	RD	3	3	—	—
	+	1BD1	RD	5	—	5	—
	-	1BD2	BK	6	—	6	—
	1	1TP1	BK/RD ^{a)}	7	—	—	7
	2	1TP2	WH ^{a)}	8	—	—	8
	⊕	PE	GNYE	GNYE	4	—	—
	Housing	Shield	—	—	Shield contact	—	—

Tab. 8: con.40 power cable pin assignment

a) Color depends on the type of temperature sensor (PTC/Pt1000), which is specified on the motor nameplate.

Length x [mm]	Diameter y [mm]
99	46

Tab. 9: con.40 connector dimensions

6.4 Encoder cables

STOBER motors are equipped with encoder systems and plug connectors as standard.

STOBER provides suitable cables in various lengths, conductor cross-sections and connector sizes.

The cables are available ready-made in the lengths 2.5 m, 5.0 m, 7.5 m, 10.0 m, 12.5 m, 15.0 m, 18.0 m, 20.0 m, 25.0 m, 30.0 m.

Other lengths on request.

6.4.1 EnDat 2.1/2.2 digital encoders

Suitable encoder cables are described below.

6.4.1.1 Connection description

Depending on the size of the motor plug connector, encoder cables are available in the following designs:

- Quick lock for con.15
- speedtec quick lock for con.17

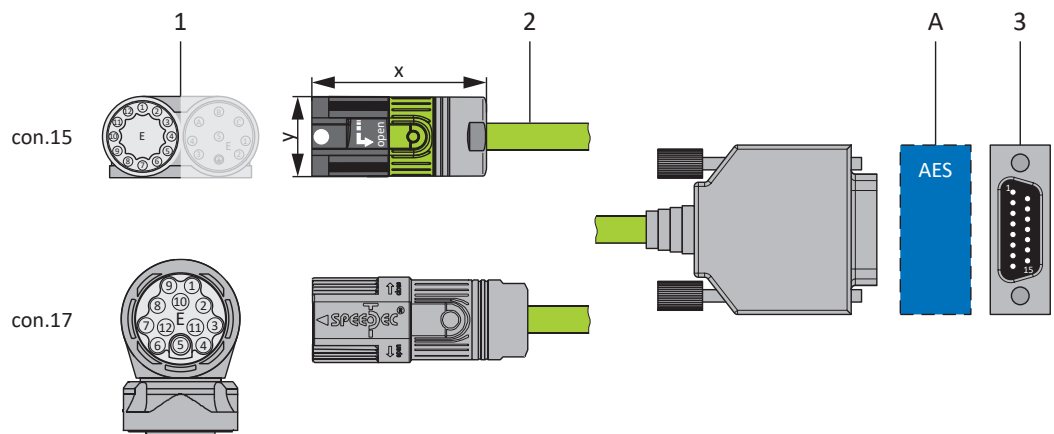

- 1 Plug connectors
- 2 STOBER encoder cable
- A Optional Absolute Encoder Support battery module (AES)
- 3 D-sub X4/X140

Encoder cables – con.15 plug connectors

The power supply is buffered for EnDat 2.2 digital "EBI 1135" and "EBI 135" inductive encoders with a multi-turn function. In this case, pin 2 and pin 3 of the motor are assigned to the U_{2BAT} buffer battery. Note that the encoder cable must not be connected to the encoder interface of the drive controller, but rather to the AES battery module for these encoders.

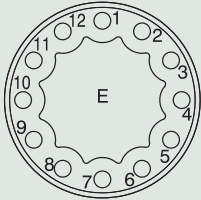
Connection diagram	Motor (1)			Cable (2)	Drive controller (3)
	Pin	Designation	Core color	Core color	Pin X4/X140
	1	Clock +	VT	YE	8
	2	U_2 Sense	BNGN	PK	12
		U_{2BAT+}^1	BU		
	3	—	—	GY	3
		U_{2BAT-}^2	WH		
	4	—	—	—	—
	5	Data –	PK	BN	13
	6	Data +	GY	WH	5
	7	—	—	—	—
	8	Clock –	YE	GN	15
	9	—	—	—	—
	10	0 V GND	WHGN	BU	2
11	—	—	—	—	
12	U_2	BNGN	RD	4	
Housing	Shield	—	—	Housing	

Tab. 10: con.15 encoder cable pin assignment, EnDat 2.1/2.2 digital

Length x [mm]	Diameter y [mm]
42	18.7

Tab. 11: con.15 connector dimensions

¹Only relevant for EBI encoders²Only relevant for EBI encoders

Encoder cables – con.17 plug connectors

The power supply is buffered for EnDat 2.2 digital "EBI 1135" and "EBI 135" inductive encoders with a multi-turn function. In this case, pin 2 and pin 3 of the motor are assigned to the U_{2BAT} buffer battery. Note that the encoder cable must not be connected to the encoder interface of the drive controller, but rather to the AES battery module for these encoders.

Connection diagram	Motor (1)			Cable (2)	Drive controller (3)
	Pin	Designation	Core color	Core color	Pin X4/X140
	1	Clock +	VT	YE	8
	2	U ₂ Sense	BNGN	PK	12
		U _{2BAT+} ³	BU		
	3	—	—	GY	3
		U _{2BAT-} ⁴	WH		
	4	—	—	—	—
	5	Data –	PK	BN	13
	6	Data +	GY	WH	5
	7	—	—	—	—
	8	Clock –	YE	GN	15
	9	—	—	—	—
	10	0 V GND	WHGN	BU	2
11	—	—	—	—	
12	U ₂	BNGN	RD	4	
Housing	Shield	—	—	Housing	

Tab. 12: con.17 encoder cable pin assignment, EnDat 2.1/2.2 digital

Length x [mm]	Diameter y [mm]
56	22

Tab. 13: con.17 connector dimensions

³Only relevant for EBI encoders

⁴Only relevant for EBI encoders

6.4.2 EnDat 2.1 sin/cos encoders

Suitable encoder cables are described below.

6.4.2.1 Connection description

Depending on the size of the motor plug connector, encoder cables are available in the following designs:

- Quick lock for con.15
- speedtec quick lock for con.17

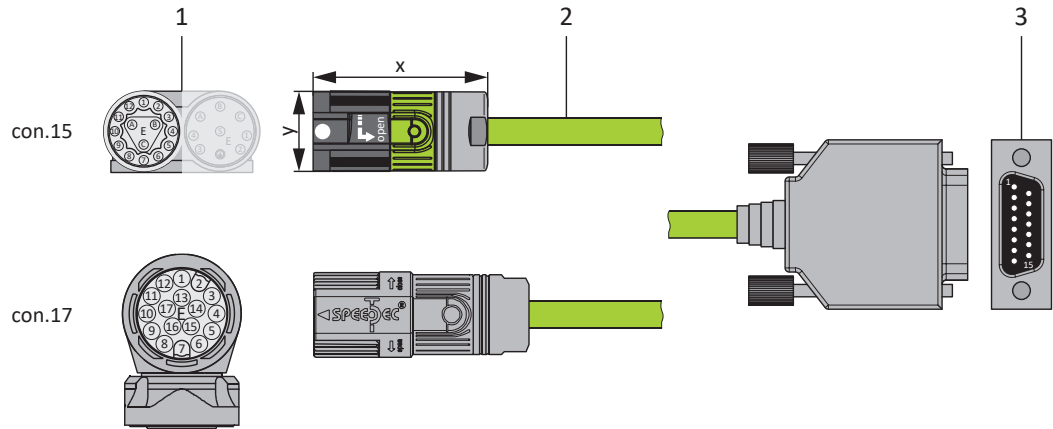

- 1 Plug connectors
- 2 STOBBER encoder cable
- 3 D-sub X140

Information

For connecting STOBBER EnDat 2.1 sin/cos cables with a 15-pin D-sub connector to an integrated motor temperature sensor, you must use the AP6A02 interface adapter (ID No. 56523), available separately, to lead out the temperature sensor cores.

Encoder cables – con.15 plug connectors

Connection diagram	Motor (1)			Cable (2)	Drive controller (3)
	Pin	Designation	Core color	Core color	Pin X140
	1	U ₂ Sense	BU	GNRD	12
	2	0 V Sense	WH	GNBK	10
	3	U ₂	BNGN	BNRD	4
	4	Clock +	VT	WHBK	8
	5	Clock -	YE	WHYE	15
	6	0 V GND	WHGN	BNBU	2
	7	B + (Sin +)	BUBK	RD	9
	8	B - (Sin -)	RDBK	OG	1
	9	Data +	GY	GY	5
	10	A + (Cos +)	GNBK	GN	11
	11	A - (Cos -)	YEBK	YE	3
	12	Data -	PK	BU	13
	A	1TP2	WH	BNGY	14
	B	1TP1	BK	BNYE	7
C	—	—	—	—	
Housing	Shield	—	—	Housing	

Tab. 14: con.15 encoder cable pin assignment, EnDat 2.1 sin/cos

Length x [mm]	Diameter y [mm]
42	18.7

Tab. 15: con.15 connector dimensions

Encoder cables – con.17 plug connectors

Connection diagram	Motor (1)			Cable (2)	Drive controller (3)
	Pin	Designation	Core color	Core color	Pin X140
	1	U ₂ Sense	BU	GNRD	12
	2	—	—	—	—
	3	—	—	—	—
	4	0 V Sense	WH	GNBK	10
	5	1TP2	WH	BNGY	14
	6	1TP1	BK	BNYE	7
	7	U ₂	BNGN	BNRD	4
	8	Clock +	VT	WHBK	8
	9	Clock -	YE	WHYE	15
	10	0 V GND	WHGN	BNBU	2
	11	—	—	—	—
	12	B + (Sin +)	BUBK	RD	9
	13	B - (Sin -)	RDBK	OG	1
	14	Data +	GY	GY	5
	15	A + (Cos +)	GNBK	GN	11
	16	A - (Cos -)	YEBK	YE	3
	17	Data -	PK	BU	13
	Housing	Shield	—	—	Housing

Tab. 16: con.17 encoder cable pin assignment, EnDat 2.1 sin/cos

Length x [mm]	Diameter y [mm]
56	22

Tab. 17: con.17 connector dimensions

6.4.3 Resolver

Suitable encoder cables are described below.

6.4.3.1 Connection description

Depending on the size of the motor plug connector, encoder cables are available in the following designs:

- Quick lock for con.15
- speedtec quick lock for con.17

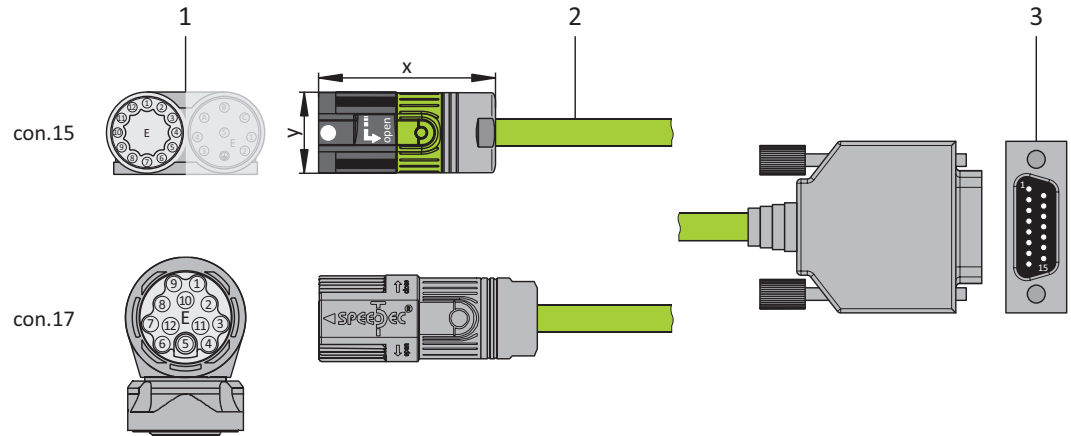

- 1 Plug connectors
- 2 STOBER encoder cable
- 3 D-sub X4/X140

Encoder cables – con.15 plug connectors

Connection diagram	Motor (1)			Cable (2)	Drive controller (3)
	Pin	Designation	Core color	Core color	Pin X4/X140
	1	S3 Cos +	BK	YE	3
	2	S1 Cos -	RD	GN	11
	3	S4 Sin +	BU	WH	1
	4	S2 Sin -	YE	BN	9
	5	1TP1	BK	RD	7
	6	1TP2	WH	BU	14
	7	R2 Ref +	YEW/ BKWH	GY	6
	8	R1 Ref -	RDWH	PK	2
	9	—	—	—	—
	10	—	—	—	—
	11	—	—	—	—
	12	—	—	—	—
	Housing	Shield	—	—	Housing

Tab. 18: con.15 encoder cable pin assignment, resolver

Length x [mm]	Diameter y [mm]
42	18.7

Tab. 19: con.15 connector dimensions

Encoder cables – con.17 plug connectors

Connection diagram	Motor (1)			Cable (2)	Drive controller (3)
	Pin	Designation	Core color	Core color	Pin X4/X140
	1	S3 Cos +	BK	YE	3
	2	S1 Cos -	RD	GN	11
	3	S4 Sin +	BU	WH	1
	4	S2 Sin -	YE	BN	9
	5	1TP1	BK	RD	7
	6	1TP2	WH	BU	14
	7	R2 Ref +	YEWH/ BKWH	GY	6
	8	R1 Ref -	RDWH	PK	2
	9	—	—	—	—
	10	—	—	—	—
	11	—	—	—	—
	12	—	—	—	—
Housing	Shield	—	—	Housing	

Tab. 20: con.17 encoder cable pin assignment, resolver

Length x [mm]	Diameter y [mm]
56	22

Tab. 21: con.17 connector dimensions

6.5 One Cable Solution EnDat 3

STOBER synchronous servo motors are equipped with plug connectors as standard.

A motor connection as a One Cable Solution (OCS) combined with an EnDat 3 encoder requires hybrid cables which feature encoder communication and power transmission in a shared cable.

STOBER provides suitable cables in various lengths, conductor cross-sections and connector sizes.

The cables are available ready-made in the lengths 2.5 m, 5.0 m, 7.5 m, 10.0 m, 12.5 m, 15.0 m, 18.0 m, 20.0 m, 25.0 m, 30.0 m.

Other lengths on request.

For applications with a cable length of up to 12.5 m, conductor cross-sections of 1.0 or 1.5 mm² and a non-moving installation, STOBER recommends the OCS-Basic hybrid cables. For longer lengths or installation in moving cable runs (such as a drag chain), please use the OCS-Advanced hybrid cables.

Information
For connecting as a One Cable Solution, use exclusively hybrid cables from STOBER. The use of unsuitable cables or poorly made connections can cause subsequent damage. For this reason, we reserve the right to reject claims under the warranty in this case.

6.5.1 Motor assignment

STOBER offers cables with a minimum cross-section for the motors as standard. Depending on the application, however, larger conductor cross-sections may be required. For this reason, take into account the following points in addition for dimensioning the cable:

- Stall current I_0 of the motor
- Permitted current carrying capacity of the conductors
- Cable length
- Terminal specifications of the drive controller or output choke
- Connector size of the motor

EZ motors – IC 410 convection cooling

	n_N 3000 rpm			n_N 4500 rpm			n_N 6000 rpm		
	K_{EM} V/1000 rpm	Plug con. size	Minimum cross-section mm ²	K_{EM} V/1000 rpm	Plug con. size	Minimum cross-section mm ²	K_{EM} V/1000 rpm	Plug con. size	Minimum cross-section mm ²
EZ202U	—	—	—	—	—	—	40	con.23	1.0 / 1.5
EZ203U	—	—	—	—	—	—	40	con.23	1.0 / 1.5
EZ301U	40	con.23	1.0 / 1.5	—	—	—	40	con.23	1.0 / 1.5
EZ302U	86	con.23	1.0 / 1.5	—	—	—	42	con.23	1.0 / 1.5
EZ303U	109	con.23	1.0 / 1.5	—	—	—	55	con.23	1.0 / 1.5
EZ401U	96	con.23	1.0 / 1.5	—	—	—	47	con.23	1.0 / 1.5
EZ402U	94	con.23	1.0 / 1.5	—	—	—	60	con.23	1.0 / 1.5
EZ404U	116	con.23	1.0 / 1.5	—	—	—	78	con.23	1.0 / 1.5
EZ501U	97	con.23	1.0 / 1.5	—	—	—	68	con.23	1.0 / 1.5
EZ502U	121	con.23	1.0 / 1.5	—	—	—	72	con.23	1.0 / 1.5
EZ503U	119	con.23	1.0 / 1.5	—	—	—	84	con.23	1.0 / 1.5
EZ505U	141	con.23	1.0 / 1.5	103	con.23	1.5	—	—	—
EZ701U	95	con.23	1.0 / 1.5	—	—	—	76	con.23	1.0 / 1.5
EZ702U	133	con.23	1.0 / 1.5	—	—	—	82	con.23	2.5
EZ703U	122	con.23	1.5	99	con.23	2.5	—	—	—
EZ705U	140	con.23	2.5	—	—	—	—	—	—

Tab. 22: Plug connector size and minimum cross-section, EZ synchronous servo motors with convection cooling

Minimum cross-section specification: The smaller cross-section is available from Q2/22 and applies to cable lengths up to max. 12.5 m.

EZ motors – IC 416 forced ventilation

	n_N 3000 rpm			n_N 4500 rpm			n_N 6000 rpm		
	K_{EM} V/1000 rpm	Plug con. size	Minimum cross-section mm ²	K_{EM} V/1000 rpm	Plug con. size	Minimum cross-section mm ²	K_{EM} V/1000 rpm	Plug con. size	Minimum cross-section mm ²
EZ401B	96	con.23	1.0 / 1.5	—	—	—	47	con.23	1.0 / 1.5
EZ402B	94	con.23	1.0 / 1.5	—	—	—	60	con.23	1.0 / 1.5
EZ404B	116	con.23	1.0 / 1.5	—	—	—	78	con.23	1.0 / 1.5
EZ501B	97	con.23	1.0 / 1.5	—	—	—	68	con.23	1.0 / 1.5
EZ502B	121	con.23	1.0 / 1.5	—	—	—	72	con.23	1.5
EZ503B	119	con.23	1.0 / 1.5	—	—	—	84	con.23	2.5
EZ505B	141	con.23	1.5	103	con.23	1.5	—	—	—
EZ701B	95	con.23	1.0 / 1.5	—	—	—	76	con.23	1.0 / 1.5
EZ702B	133	con.23	1.0 / 1.5	—	—	—	—	—	—
EZ703B	122	con.23	2.5	—	—	—	—	—	—

Tab. 23: Plug connector size and minimum cross-section, EZ synchronous servo motors with forced ventilation

Minimum cross-section specification: The smaller cross-section is available from Q2/22 and applies to cable lengths up to max. 12.5 m.

6.5.2 Connection description

The hybrid cables are available in plug connector size con.23 with a speedtec quick lock.

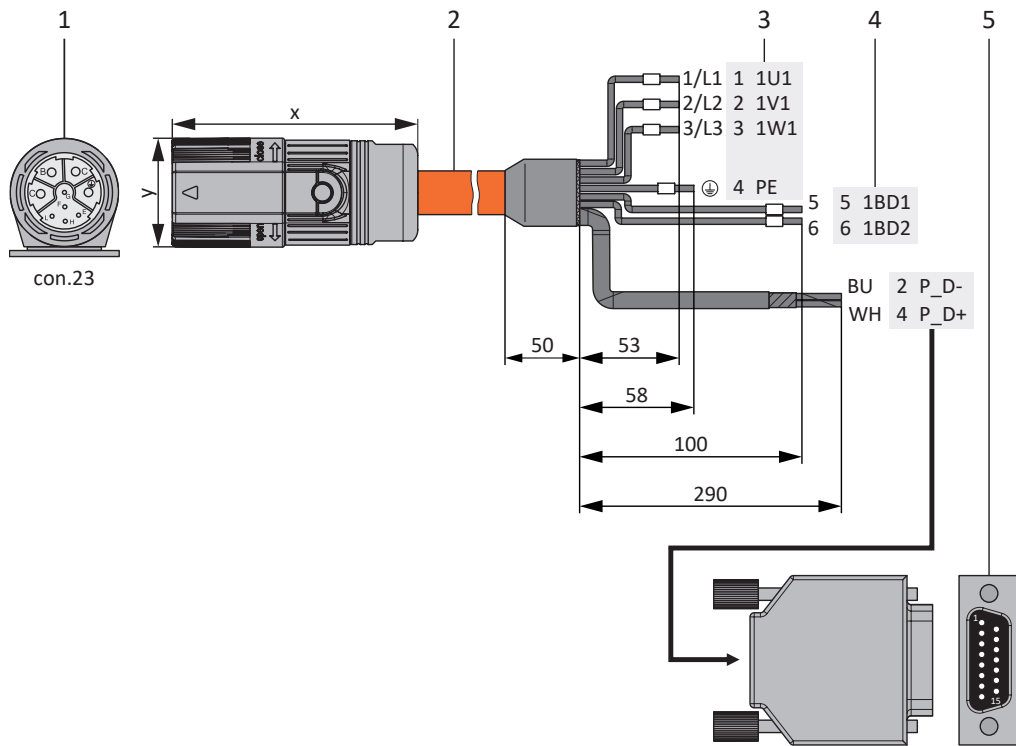

- 1 Plug connectors
- 2 STOBER hybrid cable
- 3 Connection to terminal X20, motor
- 4 Connection of terminal X2, brake
- 5 D-sub X4

Hybrid cables – con.23 plug connectors

Connection diagram	Motor (1)			Cable (2)	Drive controller (3) – (5)		
	Pin	Designation	Core color	Core No./ Core color	Pin X20	Pin X2	Pin X4
	A	1U1	BK	1/L1	1	—	—
	B	1V1	BU	2/L2	2	—	—
	C	1W1	RD	3/L3	3	—	—
	E	P_D-	YE	BU	—	—	2
	F	P_D shield	—	—	—	—	Housing
	G	1BD1	RD	5	—	5	—
	H	P_D+	VT	WH	—	—	4
	L	1BD2	BK	6	—	6	—
	⊕	PE	GNYE	GNYE	4	—	—
	Housing	Shield	—	—	Shield contact	—	—

Tab. 24: con.23 hybrid cable pin assignment

Length x [mm]	Diameter y [mm]
78	26

Tab. 25: con.23 connector dimensions

6.6 Additional documentation

Additional documentation related to the product can be found at

<http://www.stoeber.de/en/downloads/>

Enter the ID of the documentation in the Search field.

Documentation	ID
Connection method manual	443102

7 EZ synchronous servo motors

Table of contents

7.1	Overview	188
7.2	Selection tables	189
7.2.1	EZ motors with convection cooling	190
7.2.2	EZ motors with forced ventilation	191
7.3	Torque/speed curves	192
7.4	Dimensional drawings	202
7.4.1	EZ2 – EZ3 motors (One Cable Solution)	202
7.4.2	EZ2 – EZ3 motors	203
7.4.3	EZ4 – EZ7 motors with convection cooling (One Cable Solution)	204
7.4.4	EZ4 – EZ8 motors with convection cooling	205
7.4.5	EZ4 – EZ7 motors with forced ventilation (One Cable Solution)	206
7.4.6	EZ4 – EZ8 motors with forced ventilation	207
7.5	Type designation	208
7.5.1	Nameplate	208
7.6	Product description	209
7.6.1	General features	209
7.6.2	Electrical features	210
7.6.3	Ambient conditions	210
7.6.4	Encoders	210
7.6.5	Temperature sensor	213
7.6.6	Cooling	215
7.6.7	Holding brake	216
7.6.8	Connection method	218
7.7	Project configuration	225
7.7.1	Drive selection	225
7.7.2	Permitted shaft loads	227
7.7.3	Derating	228
7.8	Further information	229
7.8.1	Directives and standards	229
7.8.2	Identifiers and test symbols	229
7.8.3	Additional documentation	229

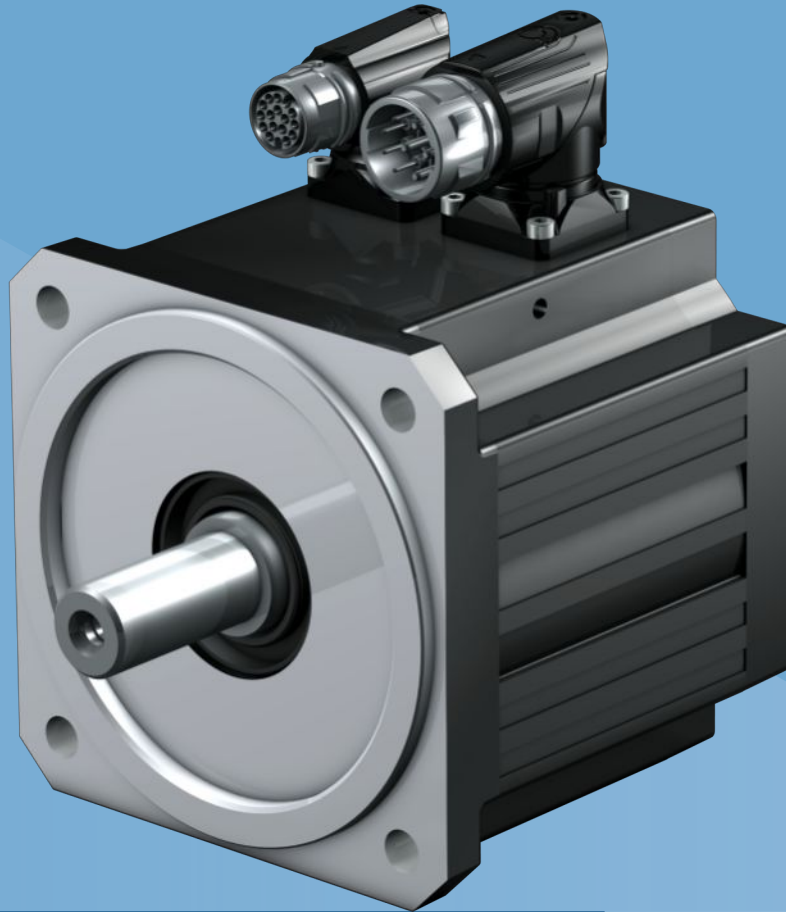

7

Synchronous servo motors

EZ

7.1 Overview

Synchronous servo motors with single tooth winding

Features

- High dynamics ✓
- Short length ✓
- Super compact due to tooth-coil winding method with the highest possible copper fill factor ✓
- Backlash-free holding brake (optional) ✓
- Electronic nameplate for fast and reliable commissioning ✓
- Convection cooling or forced ventilation (optional) ✓
- Optical, inductive EnDat absolute encoders or resolvers ✓
- Elimination of referencing with multi-turn absolute encoders (optional) ✓
- One Cable Solution (OCS) with EnDat 3 encoder (optional) ✓
- Rotatable plug connectors with quick lock ✓

Torques

M_N	0.4 – 77.2 Nm
M_0	0.44 – 94 Nm

7.2 Selection tables

The technical data specified in the selection tables applies to:

- Installation altitudes up to 1000 m above sea level
- Surrounding temperatures from -15 °C to $+40\text{ °C}$
- Operation on a STOBBER drive controller
- DC link voltage $U_{zk} = \text{DC } 540\text{ V}$
- Coating: RAL 9005 Jet black, matte

In addition, the technical data applies to an uninsulated design with the following thermal mounting conditions:

Type	Dimensions of steel mounting flange (thickness x width x height)	Convection surface area Steel mounting flange
EZ2 – EZ5	23 x 210 x 275 mm	0.16 m ²
EZ7 – EZ8	28 x 300 x 400 mm	0.3 m ²

Note the differing ambient conditions in Chapter Derating

Formula symbols

An explanation of the formula symbols can be found in Chapter Symbols in formulas.

Observe the additional information on the following formula symbols:

- I_0 = RMS value of the line-to-line current when stall torque M_0 is generated (tolerance $\pm 5\%$).
- I_{\max} = RMS value of the short-term maximum permitted line-to-line current when maximum torque M_{\max} is generated (tolerance $\pm 5\%$). Exceeding I_{\max} may lead to irreversible damage (demagnetization) of the rotor.
- I_N = RMS value of the line-to-line current when nominal torque M_N is generated at the nominal point (tolerance $\pm 5\%$).
- M_0 = Torque that a motor is continuously able to deliver at a speed of 10 rpm (tolerance $\pm 5\%$). At a speed of 0 rpm, a minor continuous torque has to be taken into account. Contact your STOBBER customer advisor for such an application.

7.2.1 EZ motors with convection cooling

Type	K_{EM} [V/1000 rpm]	n_N [rpm]	M_N [Nm]	I_N [A]	$K_{M,N}$ [Nm/A]	P_N [kW]	M_0 [Nm]	I_0 [A]	K_{M0} [Nm/A]	M_R [Nm]	M_{max} [Nm]	I_{max} [A]	R_{U-V} [Ω]	L_{U-V} [mH]	T_{el} [ms]	J_{dyn} [kgcm ²]	m_{dyn} [kg]
EZ202U	40	6000	0.40	0.99	0.41	0.25	0.44	1.03	0.45	0.03	1.48	3.48	26.00	15.80	0.61	0.13	1.43
EZ203U	40	6000	0.61	1.54	0.40	0.38	0.69	1.64	0.44	0.03	2.70	5.80	13.20	10.30	0.76	0.17	1.67
EZ301U	40	6000	0.89	1.93	0.46	0.56	0.95	2.02	0.49	0.04	2.80	12.7	11.70	39.80	3.40	0.19	1.50
EZ301U	40	3000	0.93	1.99	0.47	0.29	0.95	2.02	0.49	0.04	2.80	12.7	11.70	39.80	3.40	0.19	1.50
EZ302U	42	6000	1.50	3.18	0.47	0.94	1.68	3.48	0.49	0.04	5.00	17.8	4.50	18.70	4.16	0.29	2.10
EZ302U	86	3000	1.59	1.60	0.99	0.50	1.68	1.67	1.03	0.04	5.00	8.55	17.80	75.00	4.21	0.29	2.10
EZ303U	55	6000	1.96	3.17	0.62	1.2	2.25	3.55	0.65	0.04	7.00	16.9	4.90	21.10	4.31	0.40	2.60
EZ303U	109	3000	2.07	1.63	1.27	0.65	2.19	1.71	1.30	0.04	7.00	8.25	20.30	68.70	5.24	0.40	2.60
EZ401U	47	6000	2.30	4.56	0.50	1.4	2.80	5.36	0.53	0.04	8.50	33.0	1.94	11.52	5.94	0.93	4.00
EZ401U	96	3000	2.80	2.74	1.02	0.88	3.00	2.88	1.06	0.04	8.50	16.5	6.70	37.70	5.63	0.93	4.00
EZ402U	60	6000	3.50	5.65	0.62	2.2	4.90	7.43	0.66	0.04	16.0	43.5	1.20	8.88	7.40	1.63	5.10
EZ402U	94	3000	4.70	4.40	1.07	1.5	5.20	4.80	1.09	0.04	16.0	26.5	3.00	21.80	7.26	1.63	5.10
EZ404U	78	6000	5.80	7.18	0.81	3.6	8.40	9.78	0.86	0.04	29.0	51.0	0.89	7.07	7.94	2.98	7.20
EZ404U	116	3000	6.90	5.80	1.19	2.2	8.60	6.60	1.31	0.04	29.0	35.0	1.85	15.00	8.11	2.98	7.20
EZ501U	68	6000	3.40	4.77	0.71	2.1	4.40	5.80	0.77	0.06	16.0	31.0	2.10	12.10	5.76	2.90	5.00
EZ501U	97	3000	4.30	3.74	1.15	1.4	4.70	4.00	1.19	0.06	16.0	22.0	3.80	23.50	6.18	2.90	5.00
EZ502U	72	6000	5.20	7.35	0.71	3.3	7.80	9.80	0.80	0.06	31.0	59.0	0.76	5.60	7.37	5.20	6.50
EZ502U	121	3000	7.40	5.46	1.36	2.3	8.00	5.76	1.40	0.06	31.0	33.0	2.32	16.80	7.24	5.20	6.50
EZ503U	84	6000	6.20	7.64	0.81	3.9	10.6	11.6	0.92	0.06	43.0	63.5	0.62	5.00	8.06	7.58	8.00
EZ503U	119	3000	9.70	6.90	1.41	3.1	11.1	7.67	1.46	0.06	43.0	41.0	1.25	10.00	8.00	7.58	8.00
EZ505U	103	4500	9.50	8.94	1.06	4.5	15.3	13.4	1.15	0.06	67.0	73.0	0.50	4.47	8.94	12.2	10.9
EZ505U	141	3000	13.5	8.80	1.53	4.2	16.0	10.0	1.61	0.06	67.0	52.0	0.93	8.33	8.96	12.2	10.9
EZ701U	76	6000	5.20	6.68	0.78	3.3	7.90	9.38	0.87	0.24	20.0	31.0	0.87	8.13	9.34	8.50	8.30
EZ701U	95	3000	7.40	7.20	1.03	2.3	8.30	8.00	1.07	0.24	20.0	25.0	1.30	12.83	9.87	8.50	8.30
EZ702U	82	6000	7.20	8.96	0.80	4.5	14.3	16.5	0.88	0.24	41.0	60.5	0.34	3.90	11.47	13.7	10.8
EZ702U	133	3000	12.0	8.20	1.46	3.8	14.4	9.60	1.53	0.24	41.0	36.0	1.00	11.73	11.73	13.7	10.8
EZ703U	99	4500	12.1	11.5	1.05	5.7	20.0	17.8	1.14	0.24	65.0	78.0	0.36	4.42	12.28	21.6	12.8
EZ703U	122	3000	16.5	11.4	1.45	5.2	20.8	14.0	1.50	0.24	65.0	62.0	0.52	6.80	13.08	21.6	12.8
EZ705U	106	4500	16.4	14.8	1.11	7.7	30.0	25.2	1.20	0.24	104	114	0.22	2.76	12.55	34.0	18.3
EZ705U	140	3000	21.3	14.2	1.50	6.7	30.2	19.5	1.56	0.24	104	87.0	0.33	4.80	14.55	34.0	18.3
EZ802U	90	4500	10.5	11.2	0.94	5.0	34.5	33.3	1.05	0.30	100	135	0.13	1.90	14.60	58.0	26.6
EZ802U	136	3000	22.3	13.9	1.60	7.0	37.1	22.3	1.68	0.30	100	84.0	0.30	5.00	16.66	58.0	26.6
EZ803U	131	3000	26.6	17.7	1.50	8.4	48.2	31.1	1.56	0.30	145	124	0.18	2.79	15.50	83.5	32.7
EZ805U	142	2000	43.7	25.9	1.69	9.2	66.1	37.9	1.75	0.30	205	155	0.13	2.22	17.08	133	45.8

7.2.2 EZ motors with forced ventilation

Type	K_{EM} [V/1000 rpm]	n_N [rpm]	M_N [Nm]	I_N [A]	$K_{M,N}$ [Nm/A]	P_N [kW]	M_0 [Nm]	I_0 [A]	K_{M0} [Nm/A]	M_R [Nm]	M_{max} [Nm]	I_{max} [A]	R_{U-V} [Ω]	L_{U-V} [mH]	T_{el} [ms]	J_{dyn} [kgcm ²]	m_{dyn} [kg]
EZ401B	47	6000	2.90	5.62	0.52	1.8	3.50	6.83	0.52	0.04	8.50	33.0	1.94	11.52	5.94	0.93	5.40
EZ401B	96	3000	3.40	3.40	1.00	1.1	3.70	3.60	1.04	0.04	8.50	16.5	6.70	37.70	5.63	0.93	5.40
EZ402B	60	6000	5.10	7.88	0.65	3.2	6.40	9.34	0.69	0.04	16.0	43.5	1.20	8.88	7.40	1.63	6.50
EZ402B	94	3000	5.90	5.50	1.07	1.9	6.30	5.80	1.09	0.04	16.0	26.5	3.00	21.80	7.26	1.63	6.50
EZ404B	78	6000	8.00	9.98	0.80	5.0	10.5	12.0	0.88	0.04	29.0	51.0	0.89	7.07	7.94	2.98	8.60
EZ404B	116	3000	10.2	8.20	1.24	3.2	11.2	8.70	1.29	0.04	29.0	35.0	1.85	15.00	8.11	2.98	8.60
EZ501B	68	6000	4.50	6.70	0.67	2.8	5.70	7.50	0.77	0.06	16.0	31.0	2.10	12.10	5.76	2.90	7.00
EZ501B	97	3000	5.40	4.70	1.15	1.7	5.80	5.00	1.17	0.06	16.0	22.0	3.80	23.50	6.18	2.90	7.00
EZ502B	72	6000	8.20	11.4	0.72	5.2	10.5	13.4	0.79	0.06	31.0	59.0	0.76	5.60	7.37	5.20	8.50
EZ502B	121	3000	10.3	7.80	1.32	3.2	11.2	8.16	1.38	0.06	31.0	33.0	2.32	16.80	7.24	5.20	8.50
EZ503B	84	6000	10.4	13.5	0.77	6.5	14.8	15.9	1.07	0.06	43.0	63.5	0.62	5.00	8.06	7.58	10.0
EZ503B	119	3000	14.4	10.9	1.32	4.5	15.9	11.8	1.35	0.06	43.0	41.0	1.25	10.00	8.00	7.58	10.0
EZ505B	103	4500	16.4	16.4	1.00	7.7	22.0	19.4	1.14	0.06	67.0	73.0	0.50	4.47	8.94	12.2	12.9
EZ505B	141	3000	20.2	13.7	1.47	6.4	23.4	14.7	1.60	0.06	67.0	52.0	0.93	8.33	8.96	12.2	12.9
EZ701B	76	6000	7.50	10.6	0.71	4.7	10.2	12.4	0.84	0.24	20.0	31.0	0.87	8.13	9.34	8.50	11.2
EZ701B	95	3000	9.70	9.50	1.02	3.1	10.5	10.0	1.07	0.24	20.0	25.0	1.30	12.83	9.87	8.50	11.2
EZ702B	82	6000	12.5	16.7	0.75	7.9	19.3	22.1	0.89	0.24	41.0	60.5	0.34	3.90	11.47	13.7	13.7
EZ702B	133	3000	16.6	11.8	1.41	5.2	19.3	12.9	1.51	0.24	41.0	36.0	1.00	11.73	11.73	13.7	13.7
EZ703B	99	4500	19.8	20.3	0.98	9.3	27.2	24.2	1.13	0.24	65.0	78.0	0.36	4.42	12.28	21.6	15.7
EZ703B	122	3000	24.0	18.2	1.32	7.5	28.0	20.0	1.41	0.24	65.0	62.0	0.52	6.80	13.08	21.6	15.7
EZ705B	106	4500	27.7	25.4	1.09	13	39.4	32.8	1.21	0.24	104	114	0.22	2.76	12.55	34.0	21.2
EZ705B	140	3000	33.8	22.9	1.48	11	41.8	26.5	1.59	0.24	104	87.0	0.33	4.80	14.55	34.0	21.2
EZ802B	90	4500	30.6	30.5	1.00	14	47.4	45.1	1.06	0.30	100	135	0.13	1.90	14.60	58.0	31.6
EZ802B	136	3000	34.3	26.5	1.29	11	47.9	28.9	1.67	0.30	100	84.0	0.30	5.00	16.66	58.0	31.6
EZ803B	131	3000	49.0	35.9	1.37	15	66.7	42.3	1.58	0.30	145	124	0.18	2.79	15.50	83.5	37.7
EZ805B	142	2000	77.2	45.2	1.71	16	94.0	53.9	1.75	0.30	205	155	0.13	2.22	17.08	133	51.8

7.3 Torque/speed curves

Torque/speed curves depend on the nominal speed and/or winding design of the motor and the DC link voltage of the drive controller that is used. The following torque/speed curves apply to the DC link voltage DC 540 V.

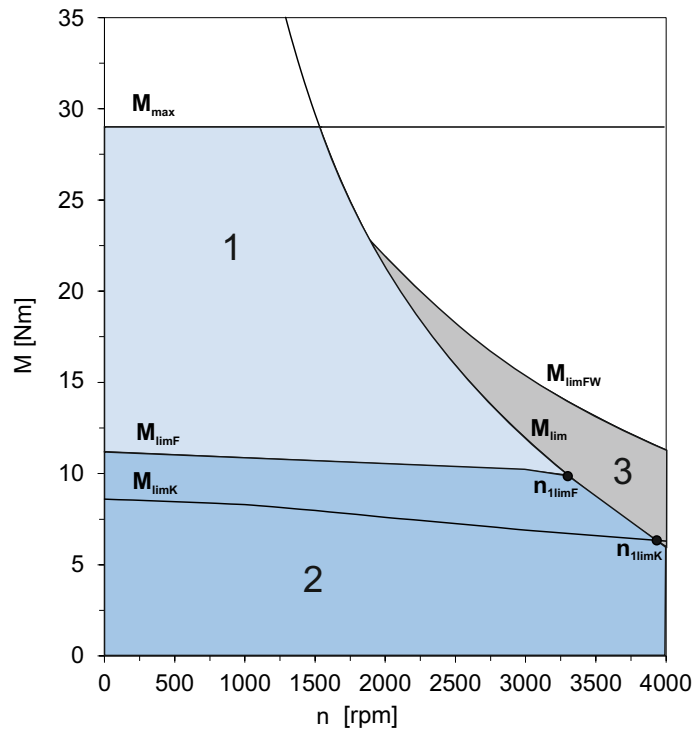
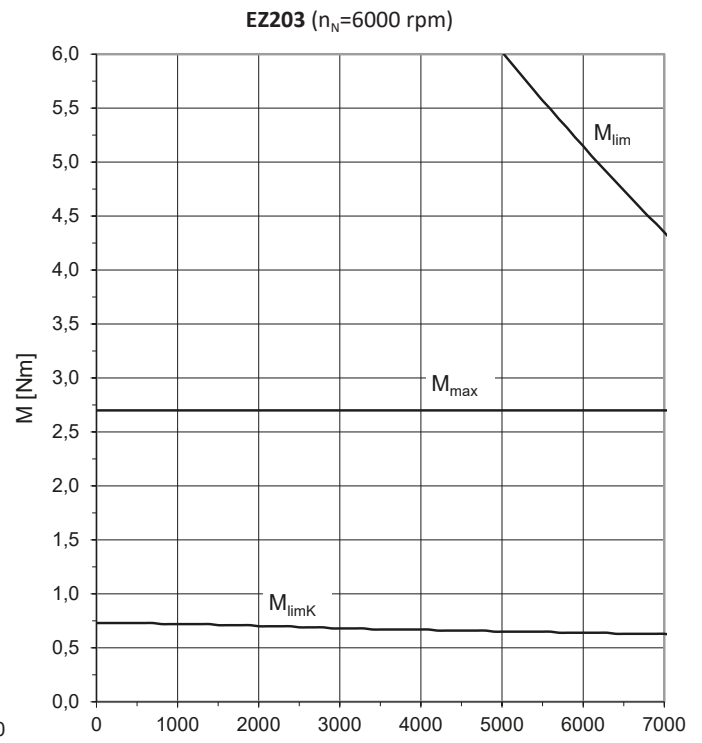
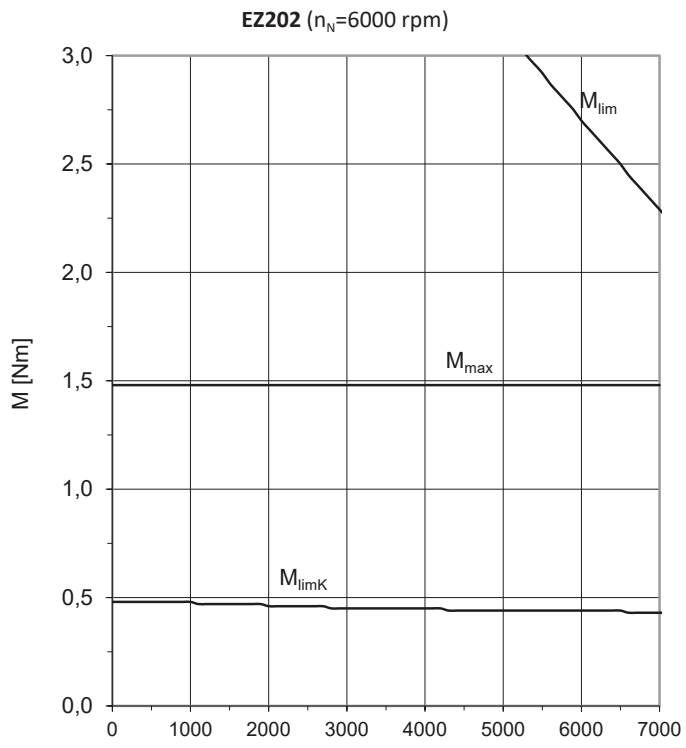
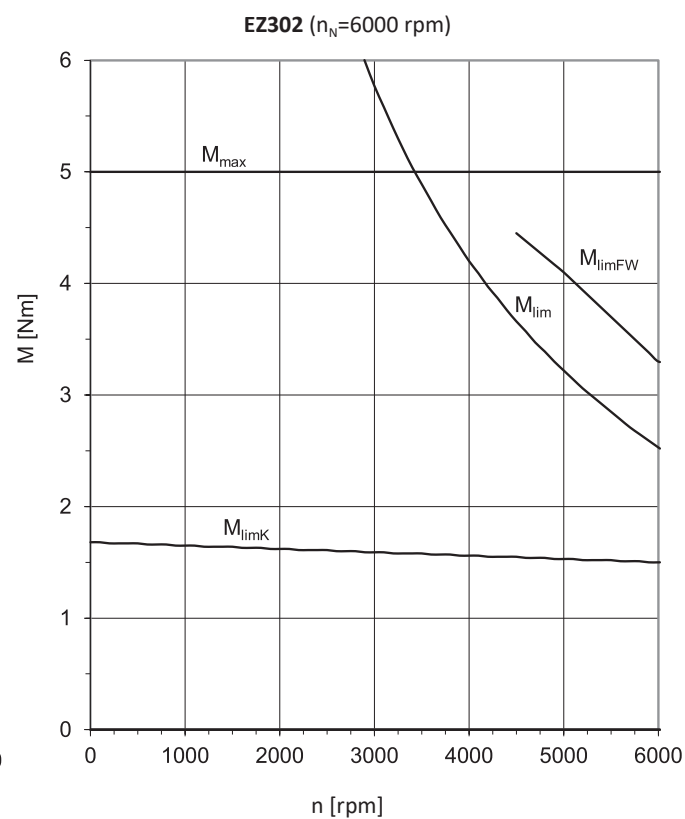
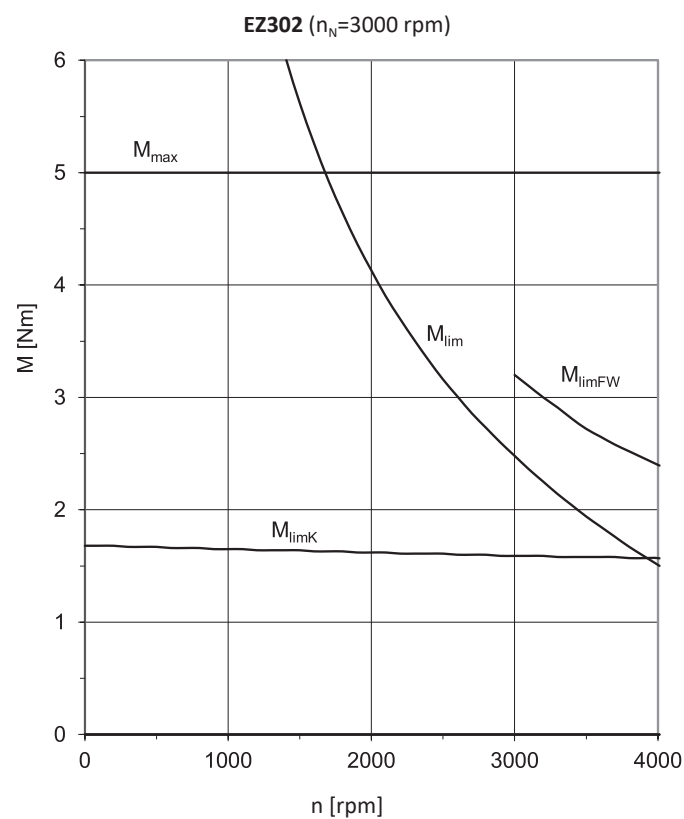
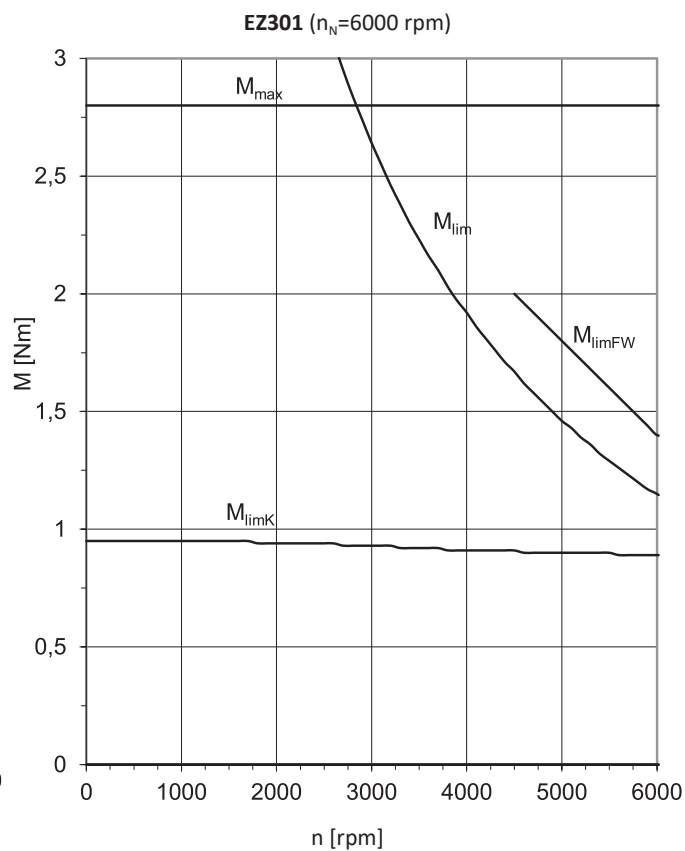
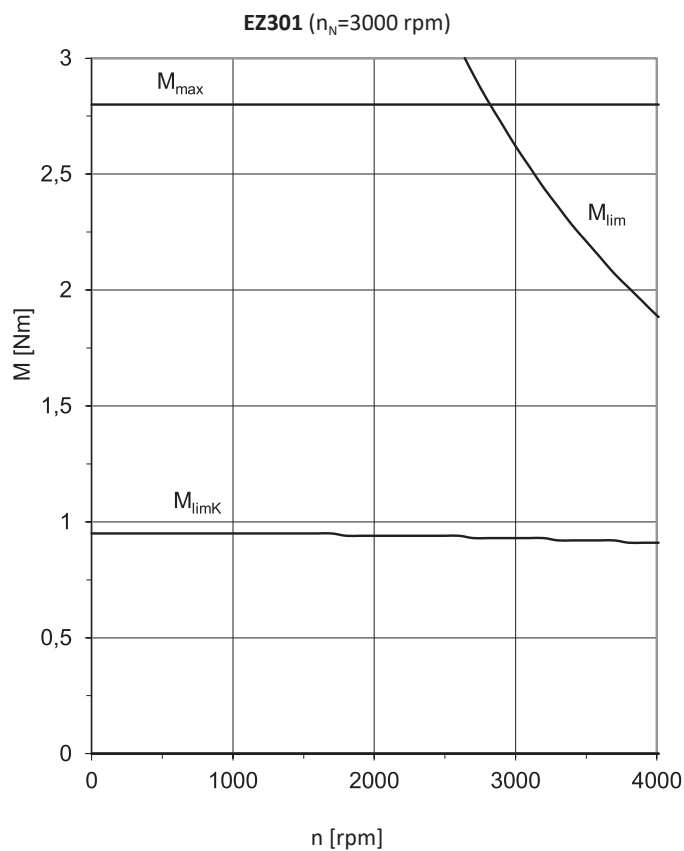
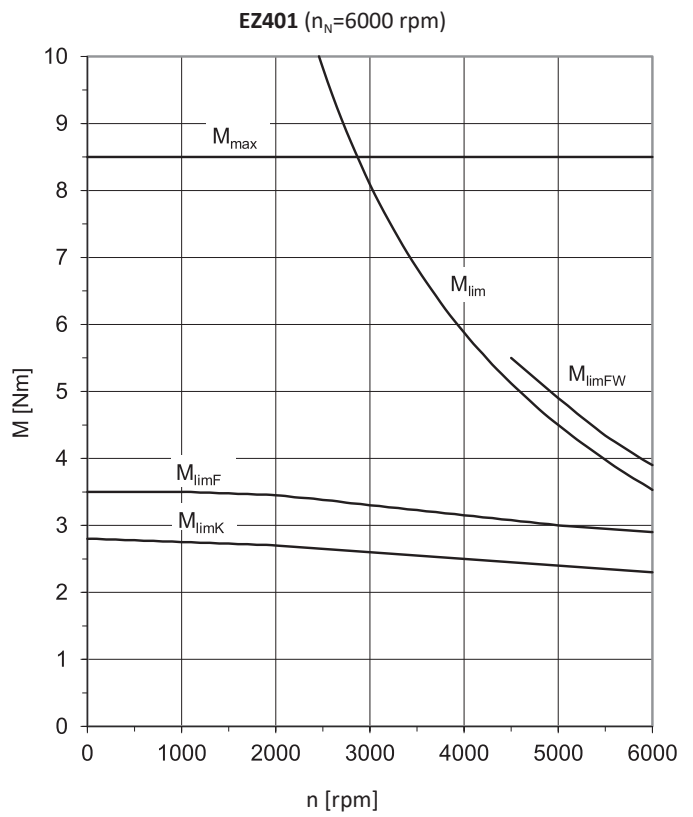
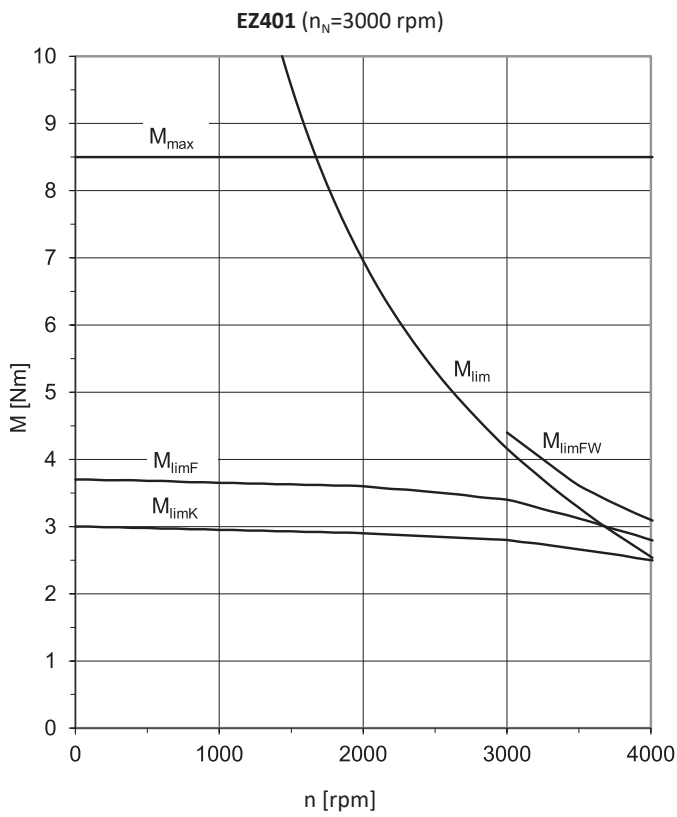
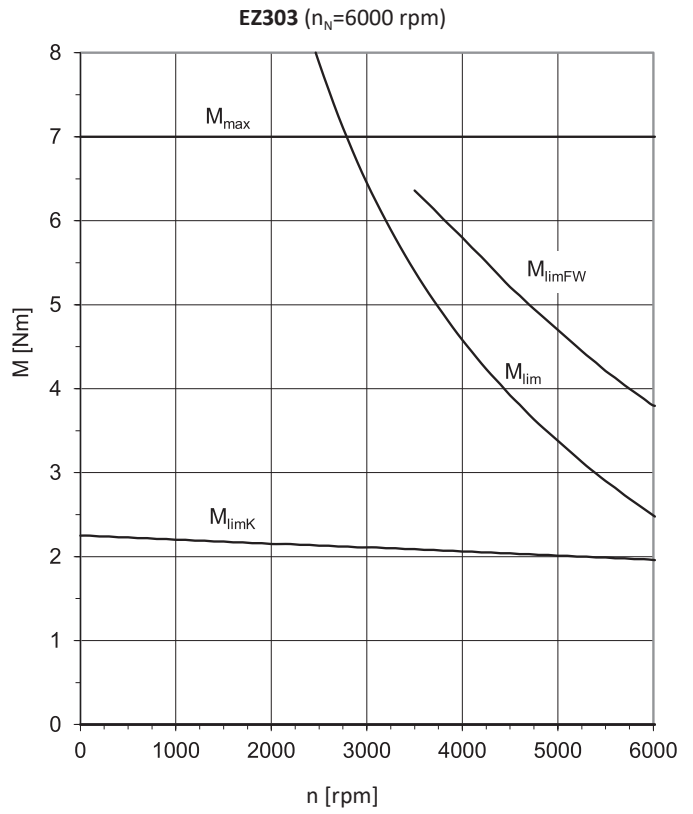
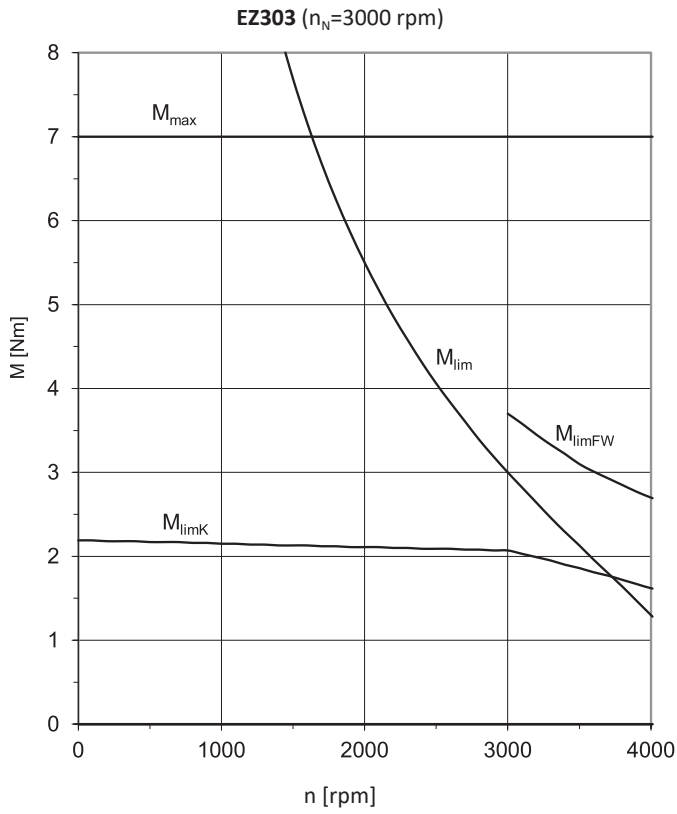

Fig. 1: Explanation of a torque/speed curve

- | | | | |
|---|---------------------------------------------------------------------------------------|---|-----------------------------------------------------------------------------------------------------------------------|
| 1 | Torque range for brief operation ($ED_{10} < 100\%$) with $\Delta\vartheta = 100$ K | 2 | Torque range for continuous operation with constant load (S1 mode, $ED_{10} = 100\%$) with $\Delta\vartheta = 100$ K |
| 3 | Field weakening range (can be used only with operation on STOBBER drive controllers) | | |







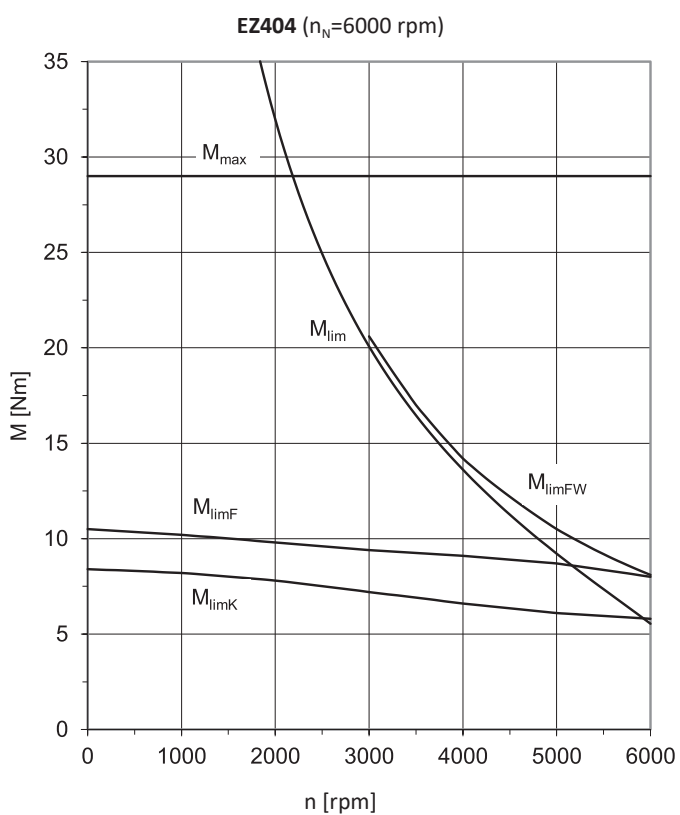
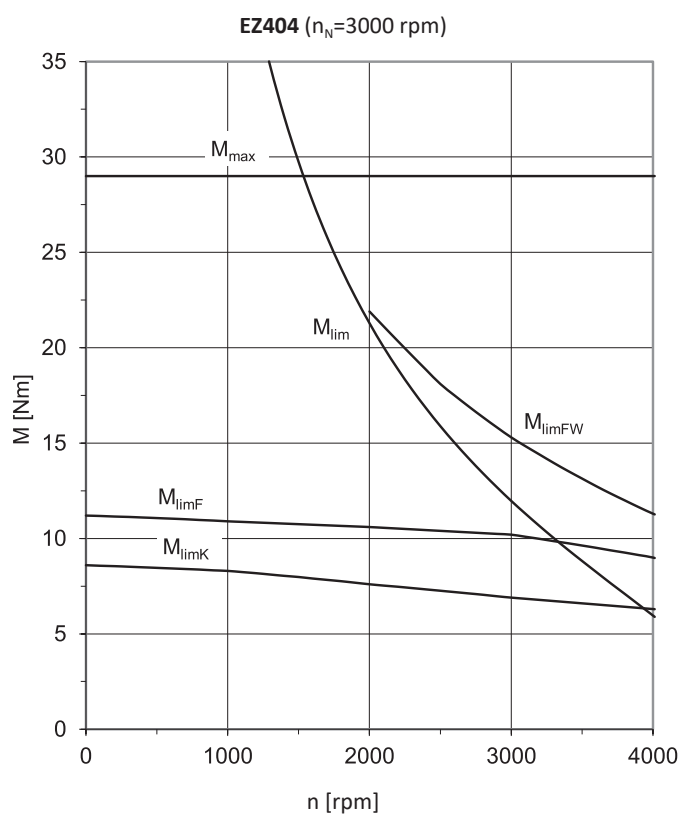
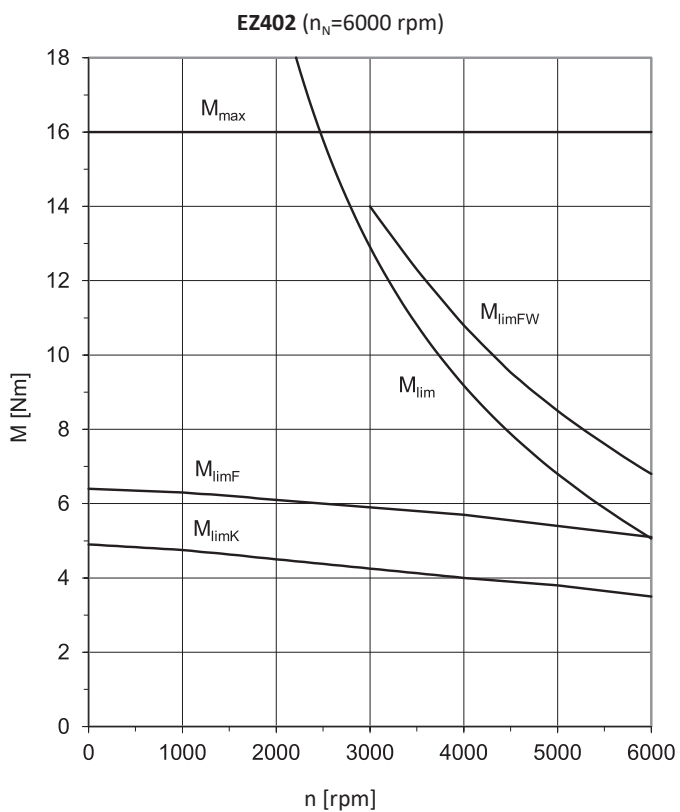
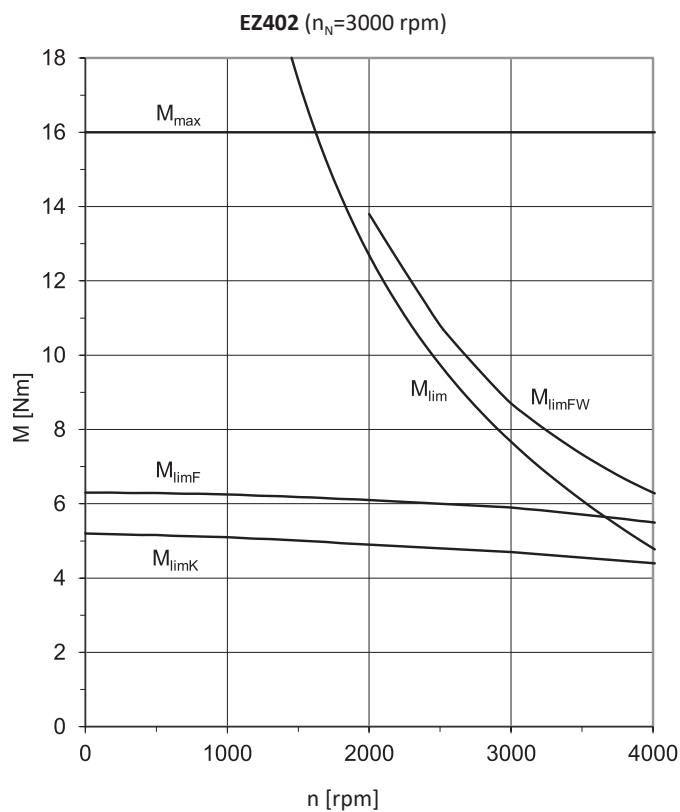

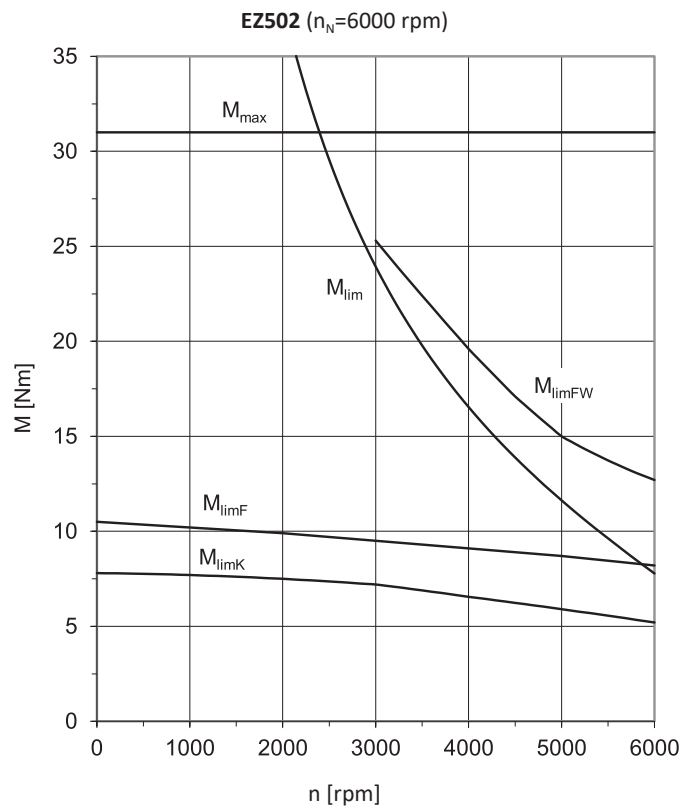
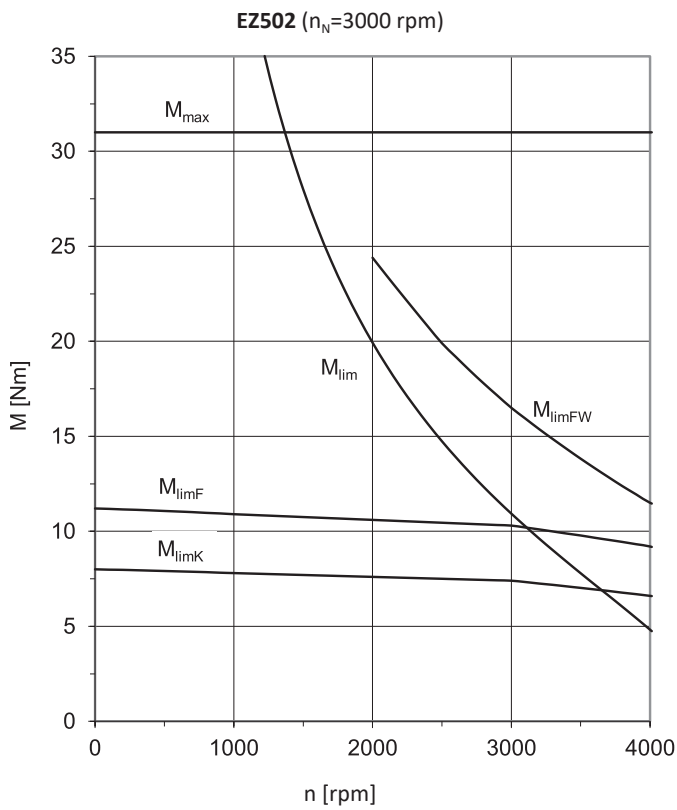
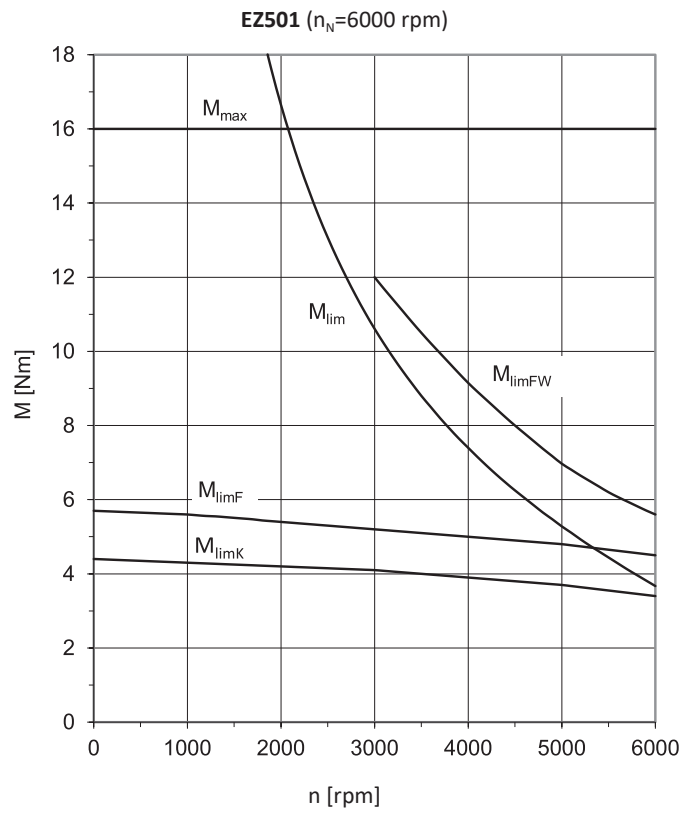
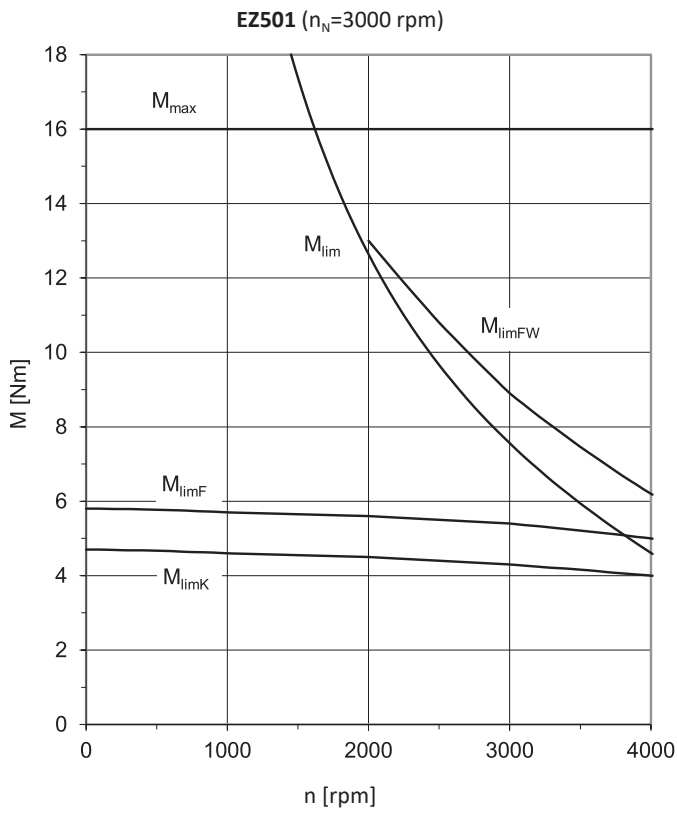

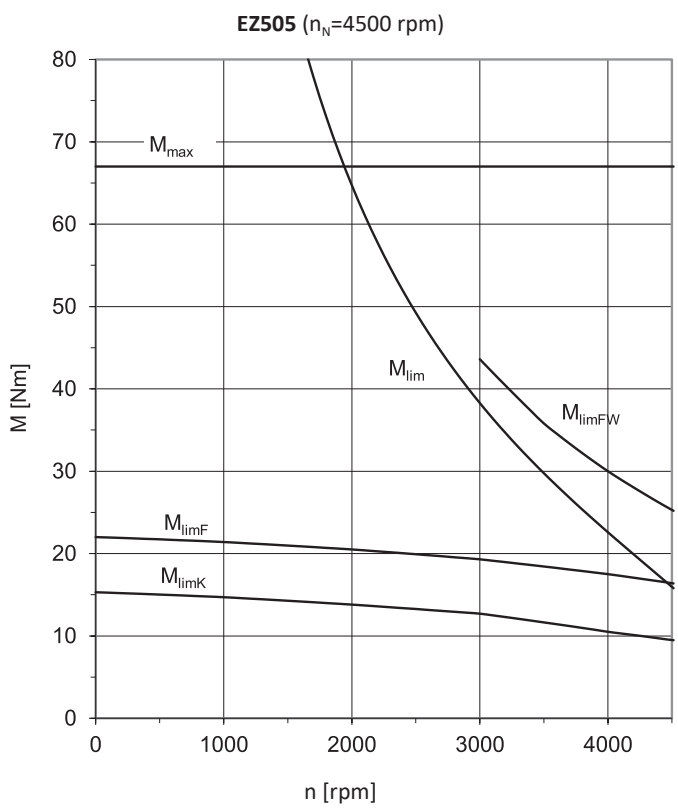
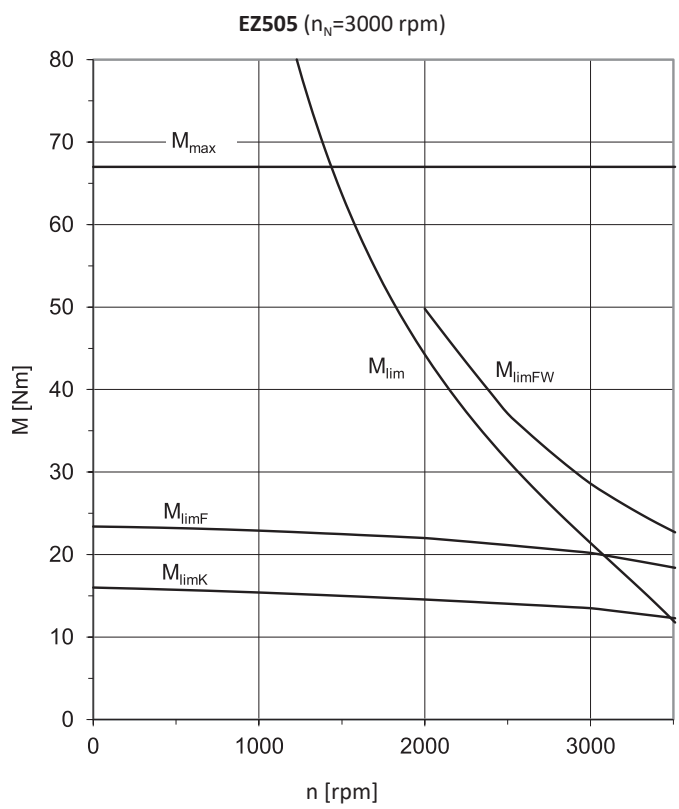
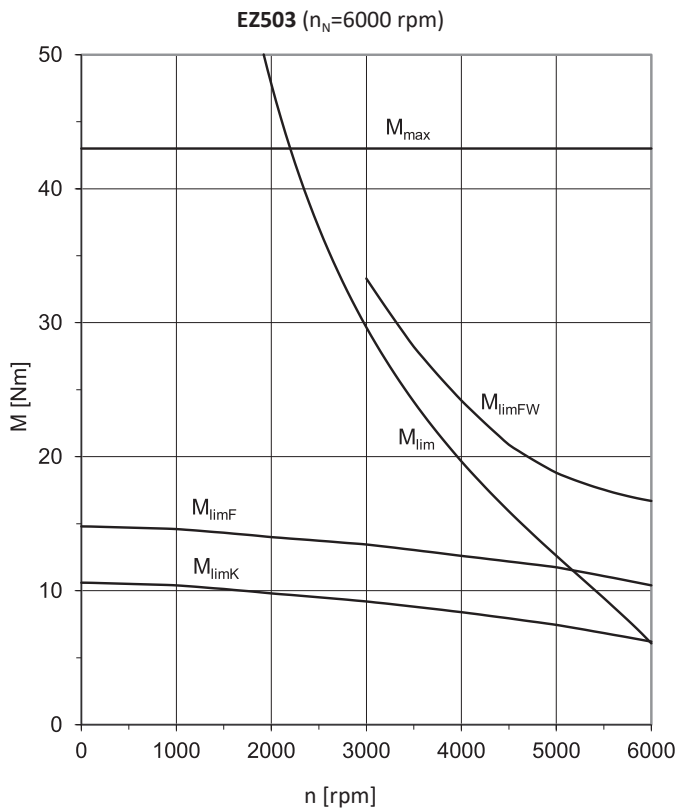
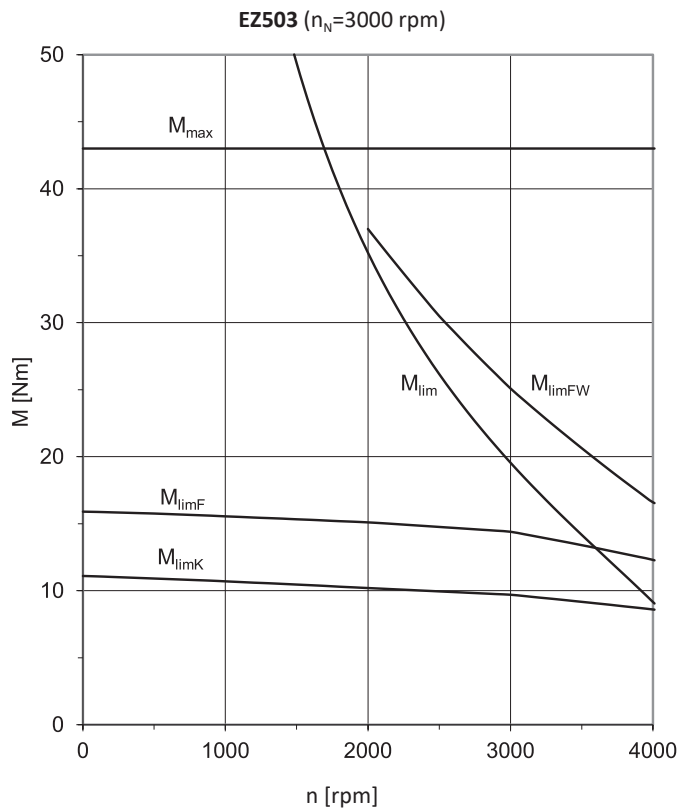

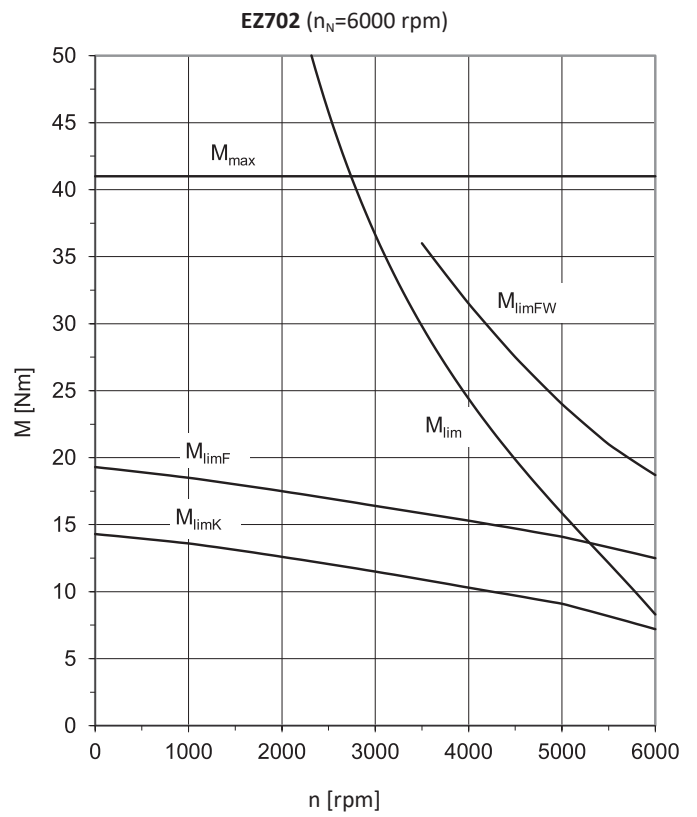
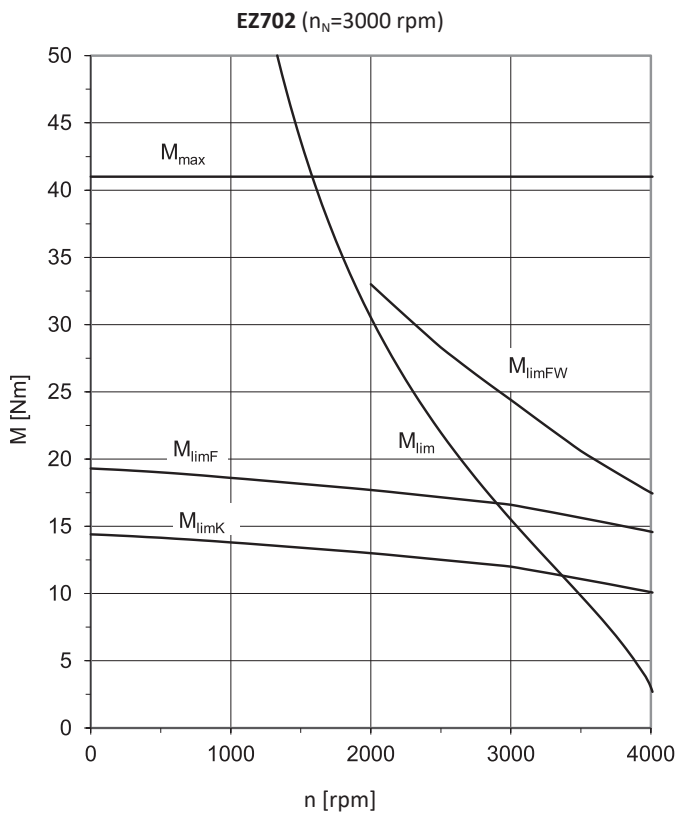
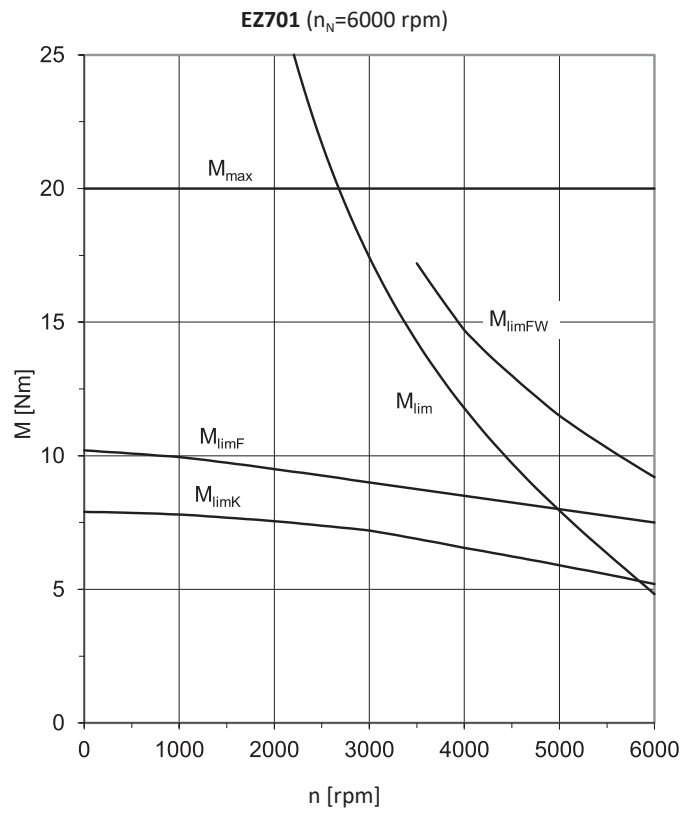
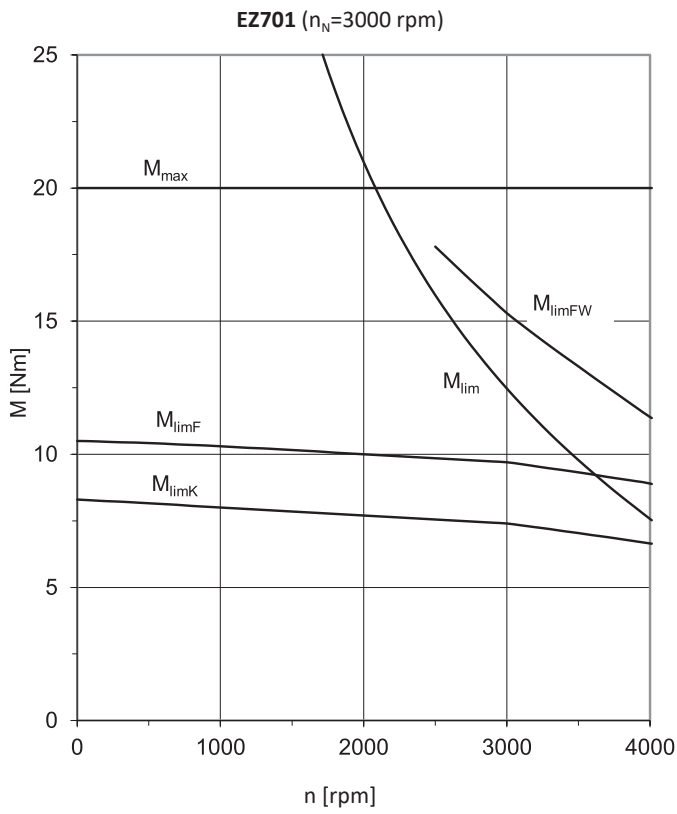

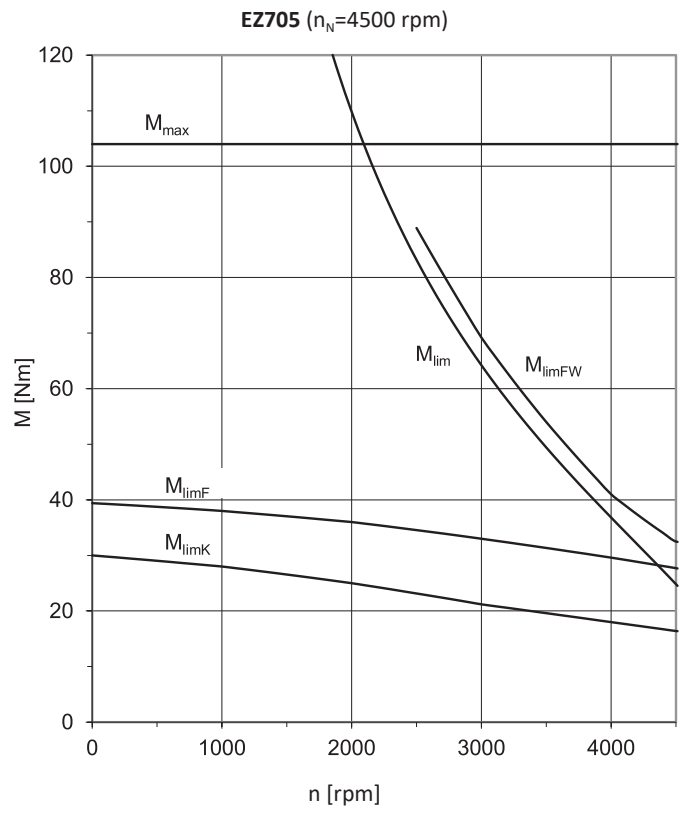
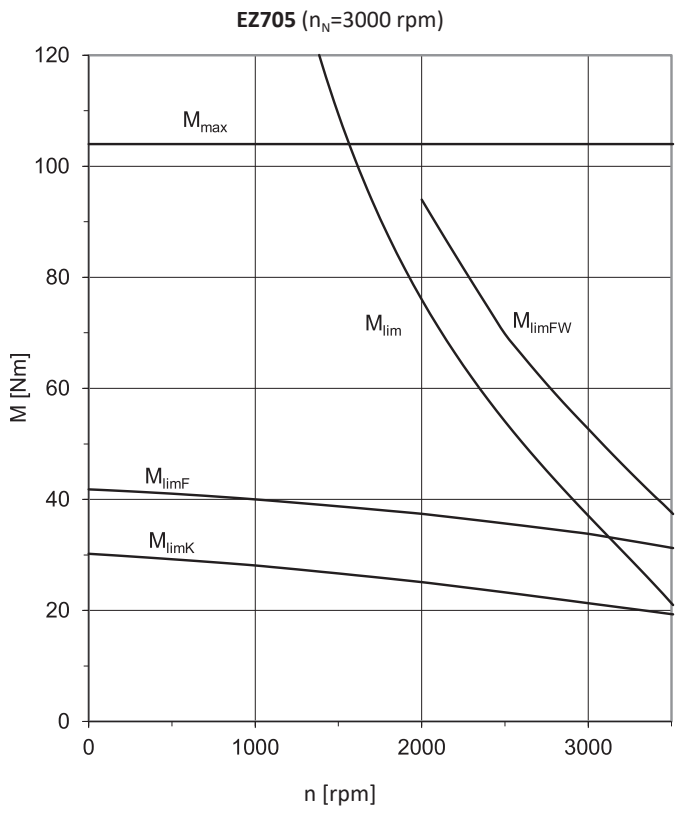
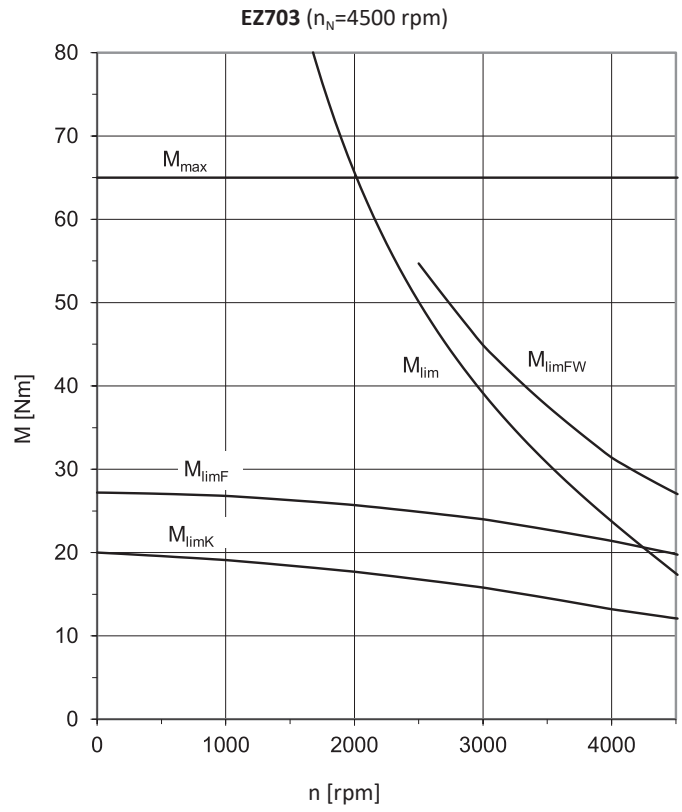
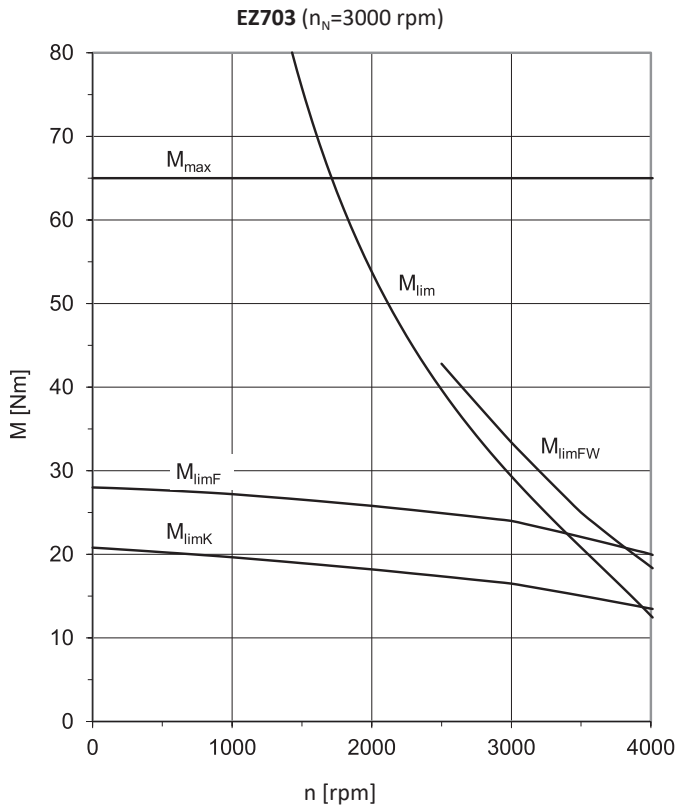

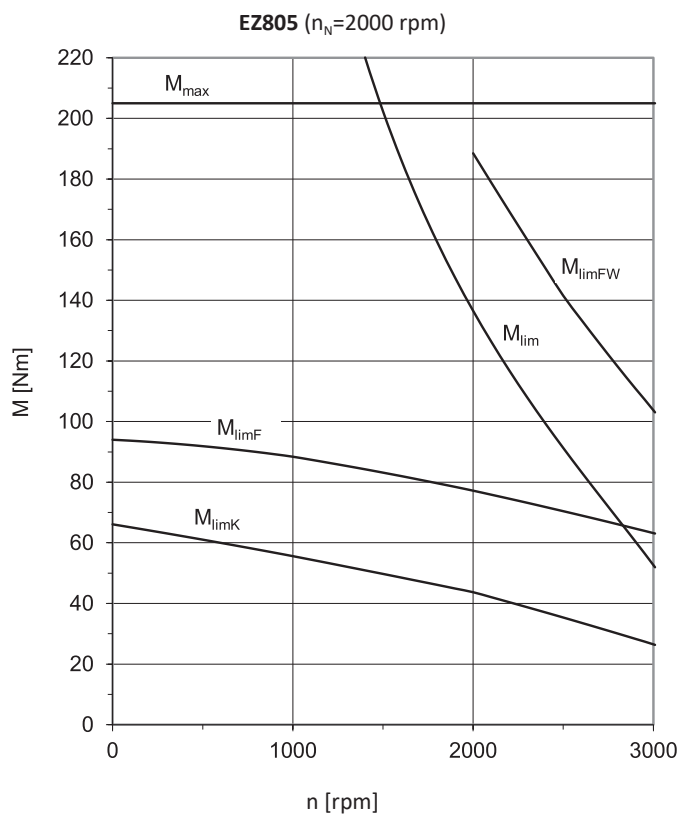
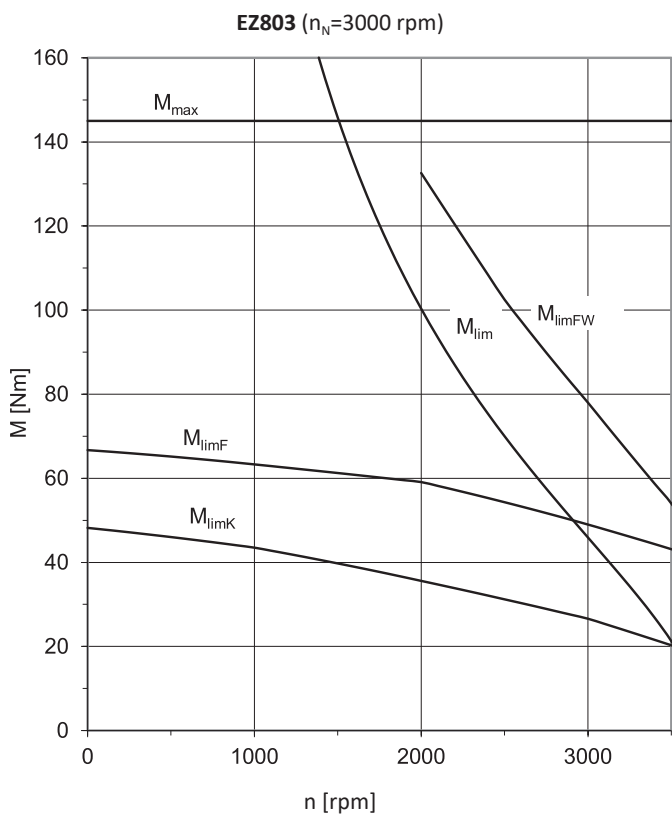
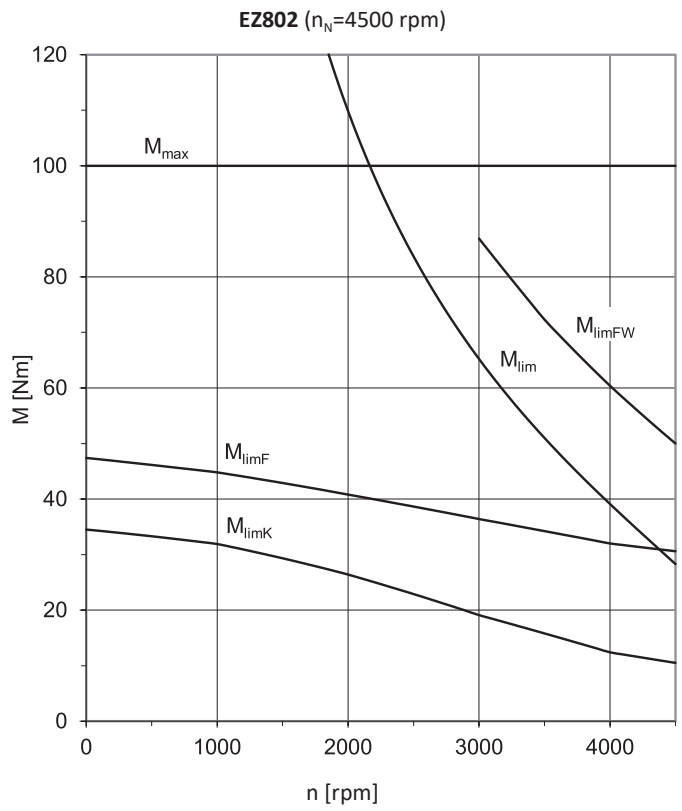
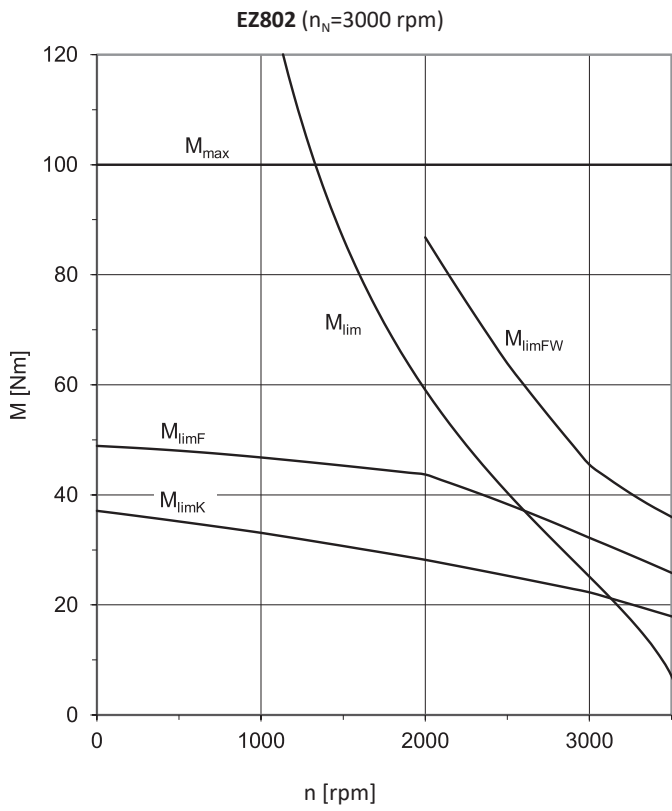

7.4 Dimensional drawings

In this chapter, you can find the dimensions of the motors.

Dimensions can exceed the specifications of ISO 2768-mK due to casting tolerances or accumulation of individual tolerances.

We reserve the right to make dimensional changes due to ongoing technical development.

You can download 3D models of our standard drives at <https://configurator.stoeber.de/en-US/>.

Tolerances

Solid shaft	Tolerance
Shaft \varnothing fit \leq 50 mm	DIN 748-1, ISO k6
Shaft \varnothing fit $>$ 50 mm	DIN 748-1, ISO m6

Centering holes in solid shafts in accordance with DIN 332-2, DR shape

Thread size	M4	M5	M6	M8	M10	M12	M16	M20	M24
Thread depth [mm]	10	12.5	16	19	22	28	36	42	50

7.4.1 EZ2 – EZ3 motors (One Cable Solution)

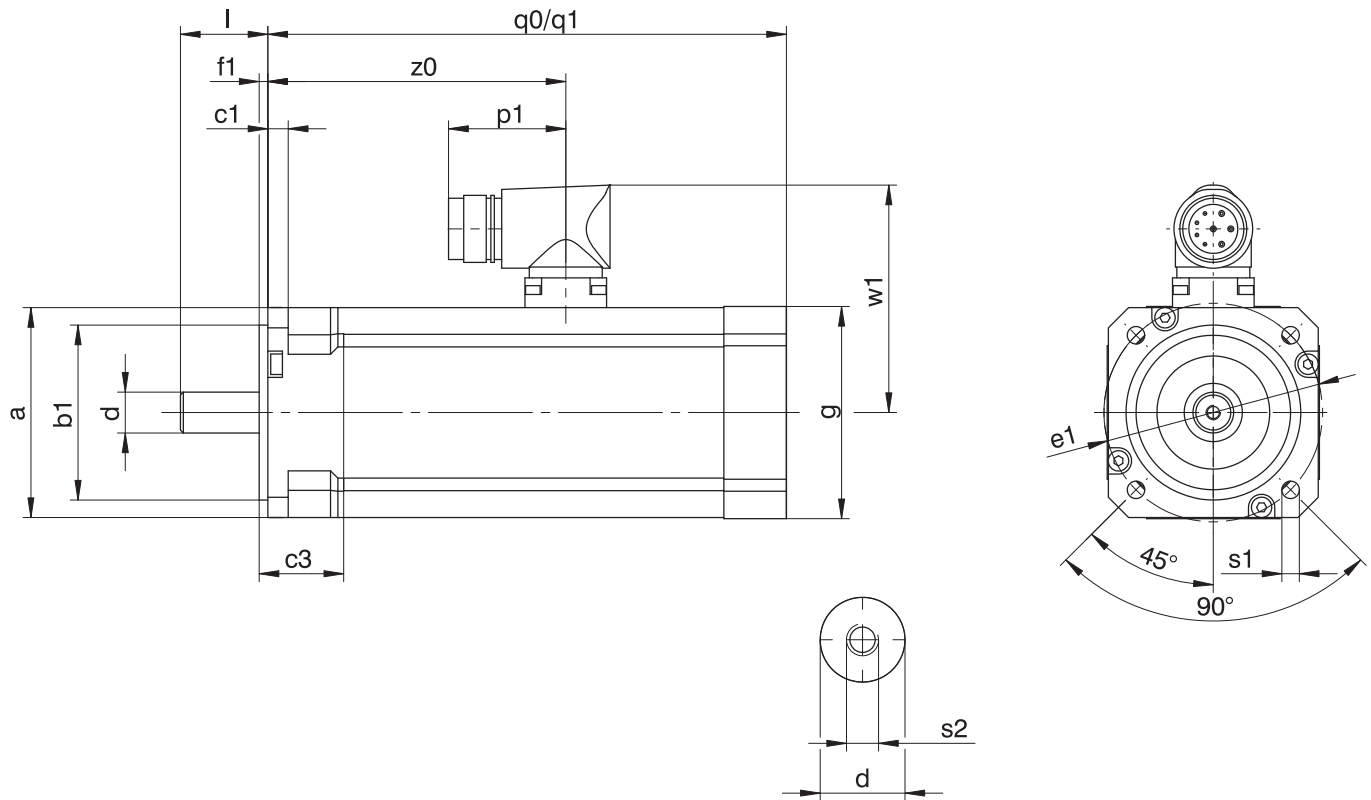

q0 Applies to motors without holding brake

q1 Applies to motors with holding brake

Type	□a	∅b1	c1	c3	∅d	∅e1	f1	□g	l	p1	q0	q1	∅s1	s2	w1	z0
EZ202U	55	40 _{f6}	7	7	9 _{k6}	63	3.5	55	20	40	148	157	5.8	M4	69.5	93.0
EZ203U	55	40 _{f6}	7	7	9 _{k6}	63	3.5	55	20	40	166	175	5.8	M4	69.5	111.0
EZ301U	72	60 _{f6}	7	26	14 _{k6}	75	3.0	72	30	40	116	156	6.0	M5	78.0	80.5
EZ302U	72	60 _{f6}	7	26	14 _{k6}	75	3.0	72	30	40	138	178	6.0	M5	78.0	102.5
EZ303U	72	60 _{f6}	7	26	14 _{k6}	75	3.0	72	30	40	160	200	6.0	M5	78.0	124.5

7.4.2 EZ2 – EZ3 motors

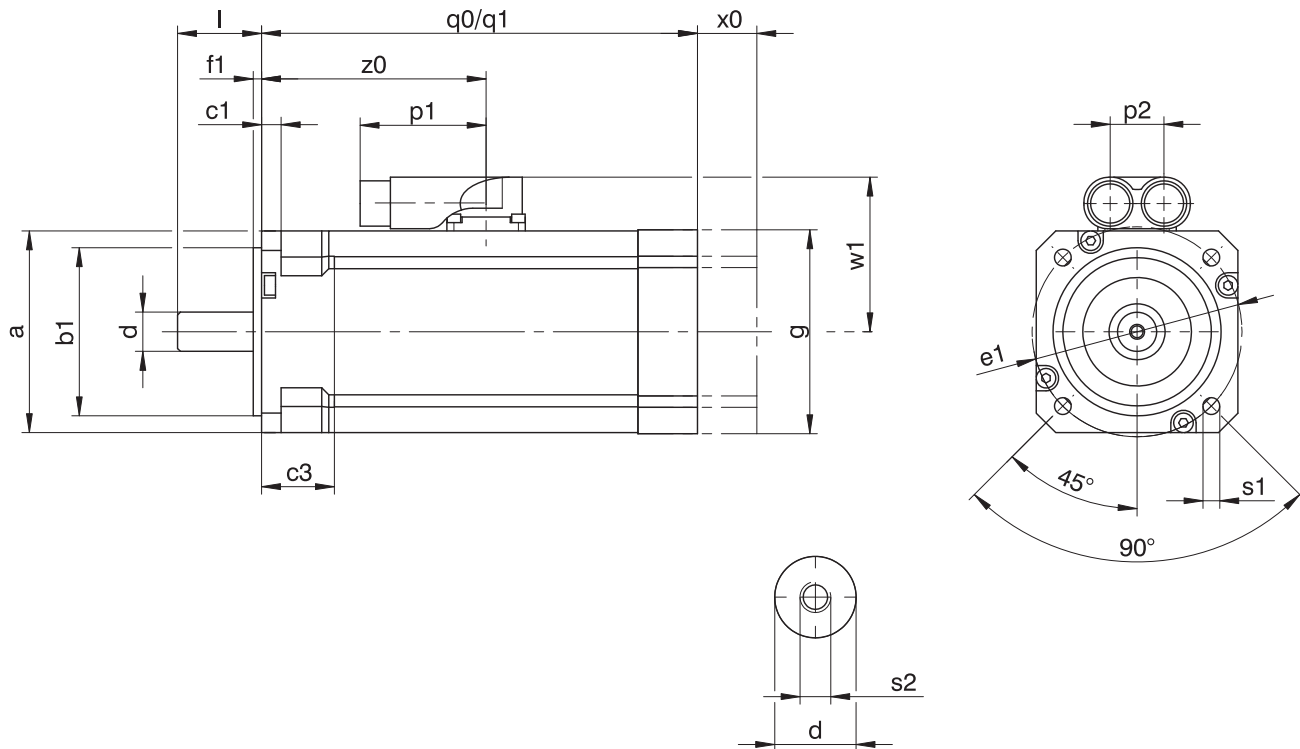

q0 Applies to motors without holding brake

q1 Applies to motors with holding brake

x0 EZ2: Applies only to motors with holding brake and encoders using an optical or inductive measuring method
 EZ3 – EZ8: Applies to encoders using an optical measuring method

Type	$\square a$	$\varnothing b1$	c1	c3	$\varnothing d$	$\varnothing e1$	f1	$\square g$	l	p1	p2	q0	q1	$\varnothing s1$	s2	w1	x0	z0
EZ202U	55	40_{j6}	7	7	9_{k6}	63	3.5	55	20	45	19	148	157	5.8	M4	47.0	25	93.0
EZ203U	55	40_{j6}	7	7	9_{k6}	63	3.5	55	20	45	19	166	175	5.8	M4	47.0	25	111.0
EZ301U	72	60_{j6}	7	26	14_{k6}	75	3.0	72	30	45	19	116	156	6.0	M5	55.5	21	80.5
EZ302U	72	60_{j6}	7	26	14_{k6}	75	3.0	72	30	45	19	138	178	6.0	M5	55.5	21	102.5
EZ303U	72	60_{j6}	7	26	14_{k6}	75	3.0	72	30	45	19	160	200	6.0	M5	55.5	21	124.5

7.4.3 EZ4 – EZ7 motors with convection cooling (One Cable Solution)

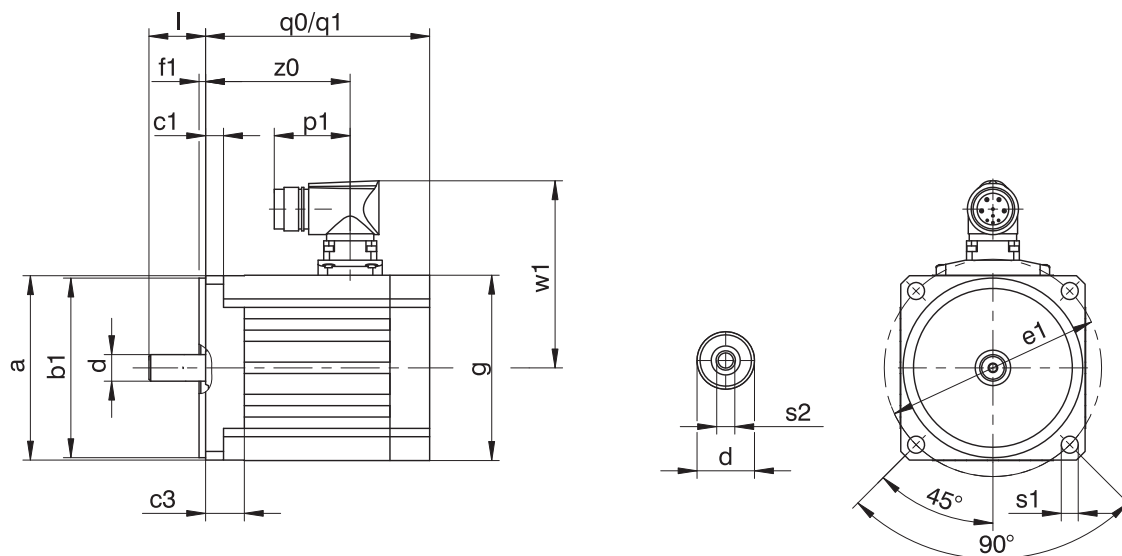

q0 Applies to motors without holding brake

q1 Applies to motors with holding brake

Type	□a	∅b1	c1	c3	∅d	∅e1	f1	□g	l	p1	q0	q1	∅s1	s2	w1	z0
EZ401U	98	95 _{js}	9.5	20.5	14 _{ks}	115	3.5	98	30	40	118.5	167.0	9	M5	99	76.5
EZ402U	98	95 _{js}	9.5	20.5	19 _{ks}	115	3.5	98	40	40	143.5	192.0	9	M6	99	101.5
EZ404U	98	95 _{js}	9.5	20.5	19 _{ks}	115	3.5	98	40	40	193.5	242.0	9	M6	99	151.5
EZ501U	115	110 _{js}	10.0	16.0	19 _{ks}	130	3.5	115	40	40	109.0	163.5	9	M6	110	74.5
EZ502U	115	110 _{js}	10.0	16.0	19 _{ks}	130	3.5	115	40	40	134.0	188.5	9	M6	110	99.5
EZ503U	115	110 _{js}	10.0	16.0	24 _{ks}	130	3.5	115	50	40	159.0	213.5	9	M8	110	124.5
EZ505U	115	110 _{js}	10.0	16.0	24 _{ks}	130	3.5	115	50	40	209.0	263.5	9	M8	110	174.5
EZ701U	145	130 _{js}	10.0	19.0	24 _{ks}	165	3.5	145	50	40	121.0	180.0	11	M8	125	83.0
EZ702U	145	130 _{js}	10.0	19.0	24 _{ks}	165	3.5	145	50	40	146.0	205.0	11	M8	125	108.0
EZ703U	145	130 _{js}	10.0	19.0	24 _{ks}	165	3.5	145	50	40	171.0	230.0	11	M8	125	133.0
EZ705U	145	130 _{js}	10.0	19.0	32 _{ks}	165	3.5	145	58	40	226.0	285.0	11	M12	125	184.0

7.4.4 EZ4 – EZ8 motors with convection cooling

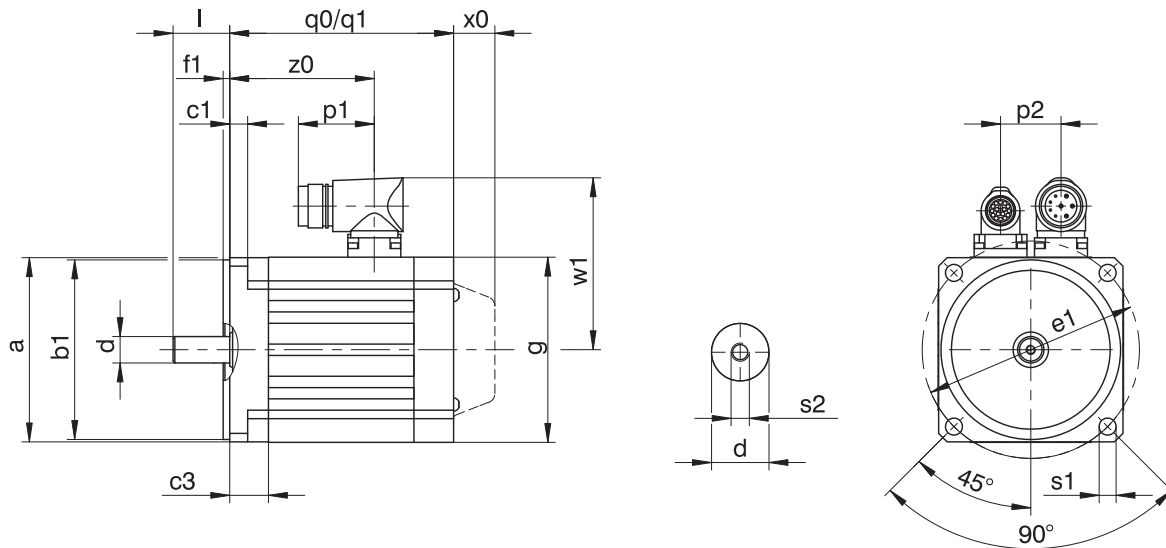

q_0 Applies to motors without holding brake

q_1 Applies to motors with holding brake

x_0 Applies to encoders based on an optical measuring method

Type	$\square a$	$\varnothing b_1$	c_1	c_3	$\varnothing d$	$\varnothing e_1$	f_1	$\square g$	l	p_1	p_2	q_0	q_1	$\varnothing s_1$	s_2	w_1	x_0	z_0
EZ401U	98	95 _{f6}	9.5	20.5	14 _{k6}	115	3.5	98	30	40	32	118.5	167.0	9	M5	91.0	22	76.5
EZ402U	98	95 _{f6}	9.5	20.5	19 _{k6}	115	3.5	98	40	40	32	143.5	192.0	9	M6	91.0	22	101.5
EZ404U	98	95 _{f6}	9.5	20.5	19 _{k6}	115	3.5	98	40	40	32	193.5	242.0	9	M6	91.0	22	151.5
EZ501U	115	110 _{f6}	10.0	16.0	19 _{k6}	130	3.5	115	40	40	36	109.0	163.5	9	M6	100.0	22	74.5
EZ502U	115	110 _{f6}	10.0	16.0	19 _{k6}	130	3.5	115	40	40	36	134.0	188.5	9	M6	100.0	22	99.5
EZ503U	115	110 _{f6}	10.0	16.0	24 _{k6}	130	3.5	115	50	40	36	159.0	213.5	9	M8	100.0	22	124.5
EZ505U	115	110 _{f6}	10.0	16.0	24 _{k6}	130	3.5	115	50	40	36	209.0	263.5	9	M8	100.0	22	174.5
EZ701U	145	130 _{f6}	10.0	19.0	24 _{k6}	165	3.5	145	50	40	42	121.0	180.0	11	M8	115.0	22	83.0
EZ702U	145	130 _{f6}	10.0	19.0	24 _{k6}	165	3.5	145	50	40	42	146.0	205.0	11	M8	115.0	22	108.0
EZ703U	145	130 _{f6}	10.0	19.0	24 _{k6}	165	3.5	145	50	40	42	171.0	230.0	11	M8	115.0	22	133.0
EZ705U	145	130 _{f6}	10.0	19.0	32 _{k6}	165	3.5	145	58	71	42	226.0	285.0	11	M12	134.0	22	184.0
EZ802U	190	180 _{f6}	15.0	25.0	32 _{k6}	215	3.5	190	58	71	60	222.0	299.0	13.5	M12	156.5	22	168.0
EZ803U	190	180 _{f6}	15.0	25.0	38 _{k6}	215	3.5	190	80	71	60	263.0	340.0	13.5	M12	156.5	22	209.0
EZ805U	190	180 _{f6}	15.0	25.0	38 _{k6}	215	3.5	190	80	71	60	345.0	422.0	13.5	M12	156.5	22	277.0

7.4.5 EZ4 – EZ7 motors with forced ventilation (One Cable Solution)

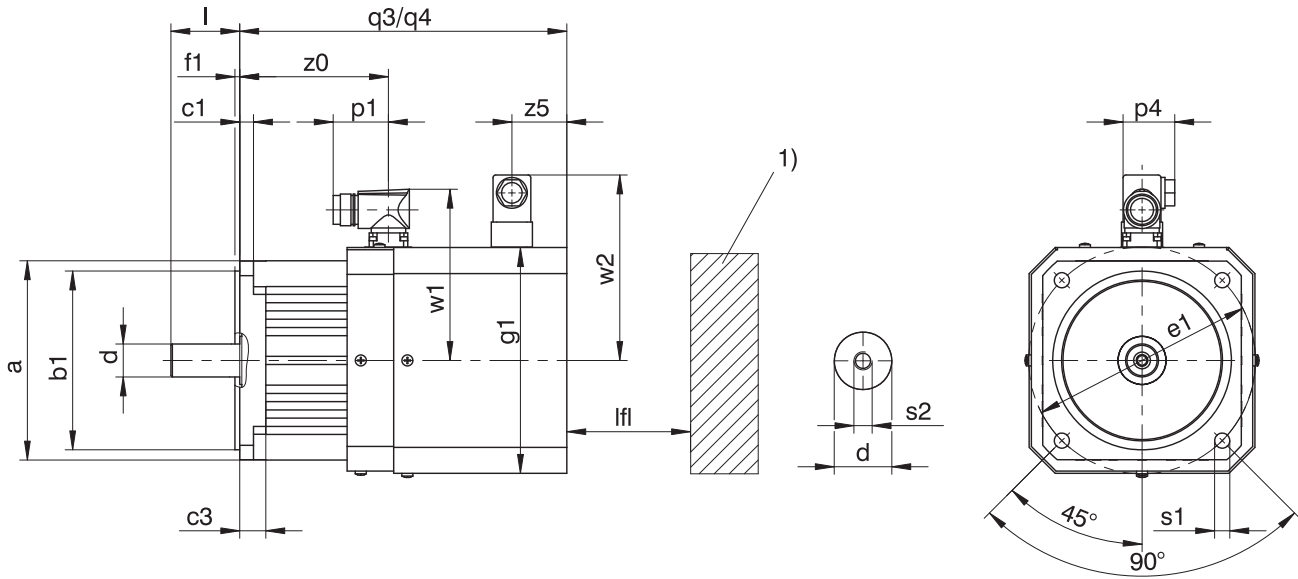

q3 Applies to motors without holding brake

q4 Applies to motors with holding brake

1) Machine wall

Type	□a	∅b1	c1	c3	∅d	∅e1	f1	□g1	l	lfl _{min}	p1	p4	q3	q4	∅s1	s2	w1	w2	z0	z5
EZ401B	98	95 _{j6}	9.5	20.5	14 _{k6}	115	3.5	118	30	20	40	37.5	175	224	9.0	M5	99	111	76.5	25
EZ402B	98	95 _{j6}	9.5	20.5	19 _{k6}	115	3.5	118	40	20	40	37.5	200	249	9.0	M6	99	111	101.5	25
EZ404B	98	95 _{j6}	9.5	20.5	19 _{k6}	115	3.5	118	40	20	40	37.5	250	299	9.0	M6	99	111	151.5	25
EZ501B	115	110 _{j6}	10.0	16.0	19 _{k6}	130	3.5	135	40	20	40	37.5	179	234	9.0	M6	110	120	74.5	25
EZ502B	115	110 _{j6}	10.0	16.0	19 _{k6}	130	3.5	135	40	20	40	37.5	204	259	9.0	M6	110	120	99.5	25
EZ503B	115	110 _{j6}	10.0	16.0	24 _{k6}	130	3.5	135	50	20	40	37.5	229	284	9.0	M8	110	120	124.5	25
EZ505B	115	110 _{j6}	10.0	16.0	24 _{k6}	130	3.5	135	50	20	40	37.5	279	334	9.0	M8	110	120	174.5	25
EZ701B	145	130 _{j6}	10.0	19.0	24 _{k6}	165	3.5	165	50	30	40	37.5	213	272	11.0	M8	125	134	83.0	40
EZ702B	145	130 _{j6}	10.0	19.0	24 _{k6}	165	3.5	165	50	30	40	37.5	238	297	11.0	M8	125	134	108.0	40
EZ703B	145	130 _{j6}	10.0	19.0	24 _{k6}	165	3.5	165	50	30	40	37.5	263	322	11.0	M8	125	134	133.0	40

7.4.6 EZ4 – EZ8 motors with forced ventilation

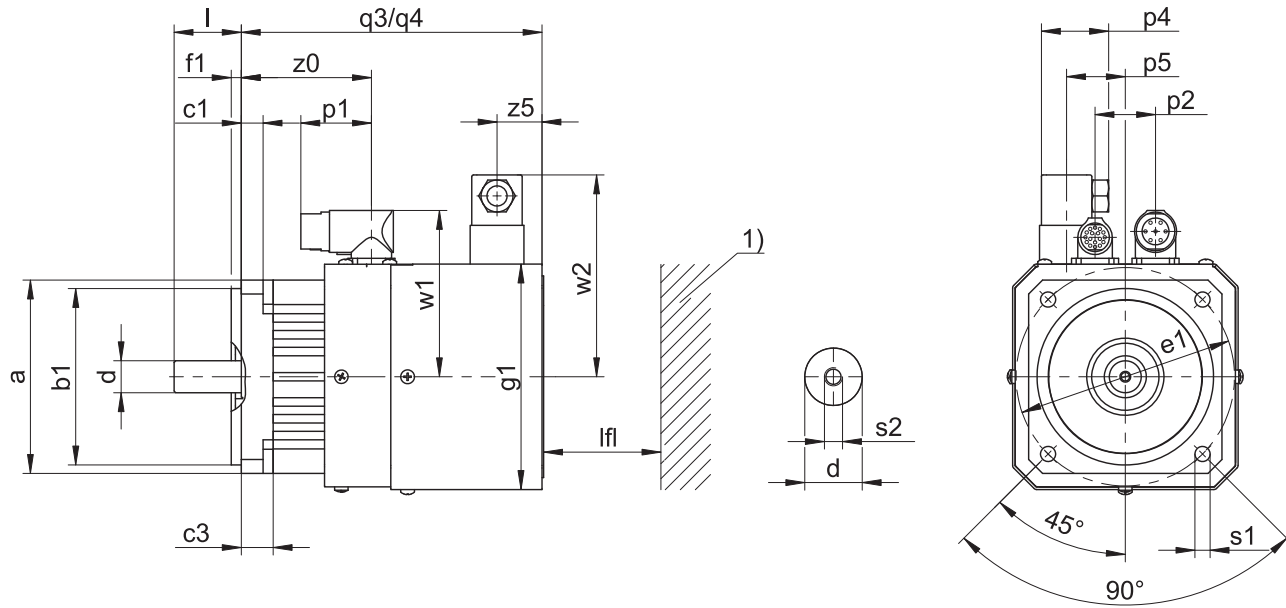

q3 Applies to motors without holding brake

q4 Applies to motors with holding brake

1) Machine wall

Type	□a	∅b1	c1	c3	∅d	∅e1	f1	□g1	l	lfl _{min}	p1	p2	p4	p5	q3	q4	∅s1	s2	w1	w2	z0	z5
EZ401B	98	95 _{f6}	9.5	20.5	14 _{k6}	115	3.5	118	30	20	40	32	37.5	0	175	224	9.0	M5	91.0	111	76.5	25
EZ402B	98	95 _{f6}	9.5	20.5	19 _{k6}	115	3.5	118	40	20	40	32	37.5	0	200	249	9.0	M6	91.0	111	101.5	25
EZ404B	98	95 _{f6}	9.5	20.5	19 _{k6}	115	3.5	118	40	20	40	32	37.5	0	250	299	9.0	M6	91.0	111	151.5	25
EZ501B	115	110 _{f6}	10.0	16.0	19 _{k6}	130	3.5	135	40	20	40	36	37.5	0	179	234	9.0	M6	100.0	120	74.5	25
EZ502B	115	110 _{f6}	10.0	16.0	19 _{k6}	130	3.5	135	40	20	40	36	37.5	0	204	259	9.0	M6	100.0	120	99.5	25
EZ503B	115	110 _{f6}	10.0	16.0	24 _{k6}	130	3.5	135	50	20	40	36	37.5	0	229	284	9.0	M8	100.0	120	124.5	25
EZ505B	115	110 _{f6}	10.0	16.0	24 _{k6}	130	3.5	135	50	20	40	36	37.5	0	279	334	9.0	M8	100.0	120	174.5	25
EZ701B	145	130 _{f6}	10.0	19.0	24 _{k6}	165	3.5	165	50	30	40	42	37.5	0	213	272	11.0	M8	115.0	134	83.0	40
EZ702B	145	130 _{f6}	10.0	19.0	24 _{k6}	165	3.5	165	50	30	40	42	37.5	0	238	297	11.0	M8	115.0	134	108.0	40
EZ703B	145	130 _{f6}	10.0	19.0	24 _{k6}	165	3.5	165	50	30	40	42	37.5	0	263	322	11.0	M8	115.0	134	133.0	40
EZ705B	145	130 _{f6}	10.0	19.0	32 _{k6}	165	3.5	165	58	30	71	42	37.5	0	318	377	11.0	M12	134.0	134	184.0	40
EZ802B	190	180 _{f6}	15.0	25.0	32 _{k6}	215	3.5	215	58	30	71	60	37.5	62	322	399	13.5	M12	156.5	160	168.0	40
EZ803B	190	180 _{f6}	15.0	25.0	38 _{k6}	215	3.5	215	80	30	71	60	37.5	62	363	440	13.5	M12	156.5	160	209.0	40
EZ805B	190	180 _{f6}	15.0	25.0	38 _{k6}	215	3.5	215	80	30	71	60	37.5	62	445	522	13.5	M12	156.5	160	277.0	40

7.5 Type designation

Example code

EZ	4	0	1	U	D	BB	Q7	O	096
----	---	---	---	---	---	----	----	---	-----

Explanation

Code	Designation	Design
EZ	Type	Synchronous servo motor
4	Size	4 (example)
0	Generation	0
1	Length	1 (example)
U	Cooling ¹	Convection cooling
B		Forced ventilation
D	Design	Dynamic
BB	Drive controller	SI6 (example)
Q7	Encoder	EnDat 3 EQI 1131 (example)
O	Brake	Without holding brake
P		Permanent magnet holding brake
096	Voltage constant K_{EM}	96 V/1000 rpm (example)

Notes

- In Chapter Encoders, you can find information about available encoders.
- In Chapter Possible combinations with drive controllers, you can find information about connecting synchronous servo motors to other drive controllers from STÖBER.

7.5.1 Nameplate

An example nameplate of an EZ401 synchronous servo motor is explained in the figure below.

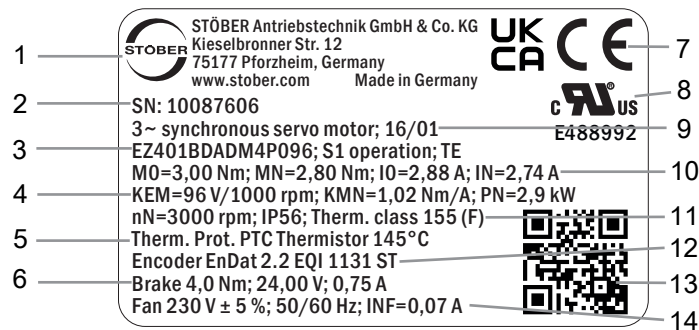

Line	Value	Description
1	STÖBER Antriebstechnik GmbH + Co. KG	Logo and address of the manufacturer
2	Ser. No. 10087606	Serial number of the motor
3	EZ401BDADM4P096 S1 operation TE	Type designation Operating mode Protection class in accordance with UL1004
4	KEM=96 V/1000 rpm KMN=1.02 Nm/A PN=2.9 kW	Voltage constant Torque constant Nominal power
5	Therm. prot. of PTC thermistor 145 °C	Type of temperature sensor
6	Brake 4.0 Nm 24.00 V 0.75 A	Holding brake (optional) Static braking torque at 100 °C Nominal voltage (DC) of the holding brake Nominal current of the holding brake at 20 °C
7	CE UKCA	CE mark UKCA mark

Line	Value	Description
8	cURus E488992	cURus test symbol, registered under UL number E488992 (optional)
9	3~ synchronous servo motor 16/01	Motor type: Three-phase synchronous servo motor Date of manufacture (year/calendar week)
10	M0=3.00 Nm MN=2.80 Nm I0=2.88 A IN=2.74 A	Stall torque Nominal torque Stall current Nominal current
11	nN=3000 rpm IP56 Therm. class 155 (F)	Nominal speed Protection class Thermal class
12	EnDat 2.2 EQI 1131 ST encoder	Encoder model
13	QR code	Link to product information
14	Fan 230 V \pm 5%; 50/60 Hz INF = 0.07 A	Forced ventilation unit (optional) Nominal voltage of the forced ventilation unit Nominal current of the forced ventilation unit

7.6 Product description

7.6.1 General features

Feature	Description
Design	IM B5, IM V1, IM V3 in accordance with EN 60034-7
Protection class	IP56 / IP66 (option)
Thermal class	155 (F) in accordance with EN 60034-1 (155 °C, heating $\Delta\theta = 100$ K)
Surface	Matte black as per RAL 9005
Cooling	IC 410 convection cooling (IC 416 convection cooling with forced ventilation units, optional)
Bearing	Rolling bearing with lifetime lubrication and non-contact sealing
Sealing	Radial shaft seal rings made of FKM (A side)
Shaft	Shaft without feather key, diameter quality k6
Radial runout	Normal tolerance class in accordance with IEC 60072-1
Concentricity	Normal tolerance class in accordance with IEC 60072-1
Axial runout	Normal tolerance class in accordance with IEC 60072-1
Vibration intensity	A in accordance with EN 60034-14
Noise level	Limit values in accordance with EN 60034-9

7.6.2 Electrical features

General electrical features of the motor are described in this chapter. Details can be found in the "Selection tables" chapter.

Feature	Description
DC link voltage	DC 540 V (max. 620 V) on STOBER drive controllers
Winding	Three-phase, single-tooth coil design
Circuit	Star, center not led through
Protection class	I (protective grounding) in accordance with EN 61140
Impulse voltage insulation class (IVIC)	C in accordance with DIN EN 60034-18-41 (inverter connection voltage 0 – 480 V ± 10%)
Number of pole pairs	2 (EZ2) 5 (EZ3) 7 (EZ4/EZ5/EZ7) 8 (EZ8)

7.6.3 Ambient conditions

Standard ambient conditions for transport, storage and operation of the motor are described in this chapter. Information about differing ambient conditions can be found in the chapter Derating.

Feature	Description
Surrounding temperature for transport/storage	–30 °C to +85 °C
Surrounding temperature for operation	–15 °C to +40 °C
Relative humidity	5% to 95%, no condensation
Installation altitude	≤ 1000 m above sea level
Shock load	≤ 50 m/s ² (5 g), 6 ms in accordance with EN 60068-2-27

Notes

- STOBER synchronous servo motors are not suitable for potentially explosive atmospheres.
- Secure the power cables close to the motor so that vibrations of the cable do not place impermissible loads on the motor plug connector.
- Note that the braking torques of the holding brake (optional) may be reduced by shock loading.
- At operating temperatures below 0 °C, note that the discs of the holding brake (optional) may ice up.
- Also take into consideration the shock load of the motor due to output units (such as gear units and pumps) which are coupled with the motor.

7.6.4 Encoders

STOBER synchronous servo motors can be designed with different encoder models. The following chapters include information for choosing the optimal encoder for your application.

7.6.4.1 Encoder measuring method selection tool

The following table offers a selection tool for an encoder measuring method that is optimally suited for your application.

Feature	Absolute encoder		Resolver
	Optical	Inductive	Electromagnetic
Measuring method			
Temperature resistance	★★☆	★★★	★★★
Vibration strength and shock resistance	★★☆	★★★	★★★
System accuracy	★★★	★★☆	★☆☆
FMA version with fault exclusion for mechanical coupling (option with EnDat interface)	✓	✓	–
Elimination of referencing with multi-turn design (optional)	✓	✓	–
Simple commissioning with electronic nameplate	✓	✓	–
Key: ★☆☆ = satisfactory, ★★☆ = good, ★★★ = very good			

7.6.4.2 Selection tool for EnDat interface

The following table offers a selection tool for the EnDat interface of absolute encoders.

Feature	EnDat 2.1	EnDat 2.2	EnDat 3
Short cycle times	★★☆	★★★	★★★
Transfer of additional information along with the position value	–	✓	✓
Expanded power supply range	★★☆	★★★	★★★
One Cable Solution (OCS)	–	–	✓
Key: ★★☆ = good, ★★★ = very good			

7.6.4.3 EnDat 3 encoders

EnDat 3 is a robust, purely digital protocol that functions with minimal connection lines. EnDat 3 facilitates the One Cable Solution, which allows the connection lines between the encoder and drive controller to be routed along in the motor's power cable.

The One Cable Solution offers the following advantages:

- Significantly reduced wiring effort by eliminating the encoder cable
- For cable lengths up to 50 m, a choke between the drive controller and motor is not necessary
- Advanced safety functions possible (up to SIL2 / category 3, PLd)
- Significantly reduced space requirements by eliminating the encoder plug connector
- Transmission of measured values from the temperature sensor using the EnDat 3 protocol

A motor with the EnDat 3 encoder can be operated only on a SI6 or SC6 drive controller from STOBBER.

The EnDat 3 encoder has the following features:

Encoder model	Code	Measuring method	Recordable revolutions	Resolution	Position values per revolution	MTTF [years]	PHF [h]
EnDat 3 EQI 1131	Q7	Inductive	4096	19 bit	524288	> 100	$\leq 15 \times 10^{-9}$

7.6.4.4 EnDat 2 encoders

In this chapter, you can find detailed technical data for encoder models that can be selected with EnDat interface.

Encoders with EnDat 2.2 interface

Encoder model	Code	Measuring method	Recordable revolutions	Resolution	Position values per revolution	MTTF [years]	PHF [h]
EnDat 2.2 EQI 1131	Q6	Inductive	4096	19 bit	524288	> 100	$\leq 15 \times 10^{-9}$
EnDat 2.2 EBI 1135	B0	Inductive	65536	18 bit	262144	> 100	$\leq 600 \times 10^{-9}$
EnDat 2.2 ECI 1118-G2	C5	Inductive	–	18 bit	262144	> 76	$\leq 1.5 \times 10^{-6}$
EnDat 2.2 EQN 1135 FMA	M3	Optical	4096	23 bit	8388608	> 100	$\leq 15 \times 10^{-9}$
EnDat 2.2 EQN 1135	Q5	Optical	4096	23 bit	8388608	> 100	$\leq 15 \times 10^{-9}$
EnDat 2.2 ECN 1123 FMA	M1	Optical	–	23 bit	8388608	> 100	$\leq 15 \times 10^{-9}$
EnDat 2.2 ECN 1123	C7	Optical	–	23 bit	8388608	> 100	$\leq 15 \times 10^{-9}$

Encoders with EnDat 2.1 interface

Encoder model	Code	Measuring method	Recordable revolutions	Resolution	Position values per revolution	Periods per revolution	MTTF [years]	PHF [h]
EnDat 2.1 EQN 1125 FMA	M2	Optical	4096	13 bit	8192	Sin/cos 512	> 57	$\leq 2 \times 10^{-6}$
EnDat 2.1 EQN 1125	Q4	Optical	4096	13 bit	8192	Sin/cos 512	> 57	$\leq 2 \times 10^{-6}$
EnDat 2.1 ECN 1113 FMA	M0	Optical	–	13 bit	8192	Sin/cos 512	> 57	$\leq 2 \times 10^{-6}$
EnDat 2.1 ECN 1113	C6	Optical	–	13 bit	8192	Sin/cos 512	> 57	$\leq 2 \times 10^{-6}$

Notes

- The encoder code is a part of the type designation of the motor.
- FMA = Version with fault exclusion for mechanical coupling.
- MTTF = Average time before dangerous failure. MTTF values greater than 100 years were reduced in accordance with DIN EN ISO 13849.
- PHF = Probability of a dangerous failure per hour
- The EnDat 2.2 EBI 1135 encoder requires an external buffer battery so that absolute position information is retained after the power supply is turned off (AES option for STOBBER drive controllers).
- Multiple revolutions of the motor shaft can be recorded only using multi-turn encoders.

7.6.4.5 Resolver

In this chapter, you can find detailed technical data for the resolver that can be installed as an encoder in a STOBBER synchronous servo motor.

Feature	Description
Number of poles	2
Input voltage $U_{1\text{eff}}$	7 V \pm 5%
Input frequency f_1	10 kHz
Output voltage $U_{2,S1-S3}$	$K_{tr} \cdot U_{R1-R2} \cdot \cos \theta$
Output voltage $U_{2,S2-S4}$	$K_{tr} \cdot U_{R1-R2} \cdot \sin \theta$
Transformation ratio K_{tr}	0.5 \pm 5%
Electrical fault	± 10 arcmin
MTTF	> 100 years
PHF	$\leq 10^{-9}$

7.6.4.6 Possible combinations with drive controllers

The following table shows the options for combining STOBBER drive controllers with selectable encoder models.

Drive controller		SDS 5000		SD6		SI6			SC6		
Drive controller code		AA	AC	AD	AE	AP	AQ	BB	AU	AV	BA
Connection plan ID		442305	442307	442450	442451	442771	442772	443175	443052	443053	443174
Encoder	Encoder code										
EnDat 3 EQI 1131	Q7	–	–	–	–	–	–	✓	–	–	✓
EnDat 2.2 EQI 1131	Q6	✓	–	✓	–	✓	–	–	✓	–	–
EnDat 2.2 EQN 1135 FMA	M3	✓	–	✓	–	–	–	–	–	–	–
EnDat 2.2 EQN 1135	Q5	✓	–	✓	–	✓	–	–	✓	–	–
EnDat 2.2 ECN 1123 FMA	M1	✓	–	✓	–	–	–	–	–	–	–
EnDat 2.2 ECN 1123	C7	✓	–	✓	–	✓	–	–	✓	–	–
EnDat 2.2 ECI 1118-G2	C5	✓	–	✓	–	✓	–	–	✓	–	–
EnDat 2.1 EQN 1125 FMA	M2	✓	✓	✓	✓	–	–	–	–	–	–
EnDat 2.1 EQN 1125	Q4	✓	✓	✓	✓	–	–	–	–	–	–
EnDat 2.1 ECN 1113 FMA	M0	✓	✓	✓	✓	–	–	–	–	–	–
EnDat 2.1 ECN 1113	C6	✓	✓	✓	✓	–	–	–	–	–	–
Resolver	R0	✓	–	–	✓	–	✓	–	–	✓	–

Notes

- The drive controller and encoder codes are a part of the type designation of the motor (see the "Type designation" chapter).

7.6.5 Temperature sensor

In this chapter, you can find technical data for the temperature sensors that are installed in STOBBER synchronous servo motors for implementing thermal winding protection. To prevent damage to the motor, always monitor the temperature sensor with appropriate devices that will turn off the motor if the maximum permitted winding temperature is exceeded.

Some encoders feature integrated temperature monitoring, the warning and switch-off thresholds of which may overlap with the corresponding values set for the temperature sensor in the drive controller. In some cases, this may result in an instance where an encoder with internal temperature monitoring forces the motor to shut down, even before the motor has reached its nominal data.

You can find information about the electrical connection of the temperature sensor in the "Connection method" chapter.

7.6.5.1 PTC thermistor

The PTC thermistor is installed as a standard temperature sensor in STOBBER synchronous servo motors.

The PTC thermistor is a triple thermistor in accordance with DIN 44082 that can be used for monitoring the temperature of each winding phase. The resistance values in the following table and curve refer to a single thermistor in accordance with DIN 44081. These values must be multiplied by 3 for a triple thermistor in accordance with DIN 44082.

Feature	Description
Nominal response temperature ϑ_{NAT}	145 °C ± 5 K
Resistance R -20 °C up to $\vartheta_{NAT} - 20$ K	≤ 250 Ω
Resistance R with $\vartheta_{NAT} - 5$ K	≤ 550 Ω
Resistance R with $\vartheta_{NAT} + 5$ K	≥ 1330 Ω
Resistance R with $\vartheta_{NAT} + 15$ K	≥ 4000 Ω
Operating voltage	≤ DC 7.5 V
Thermal response time	< 5 s
Thermal class	155 (F) in accordance with EN 60034-1 (155 °C, heating $\Delta\vartheta = 100$ K)

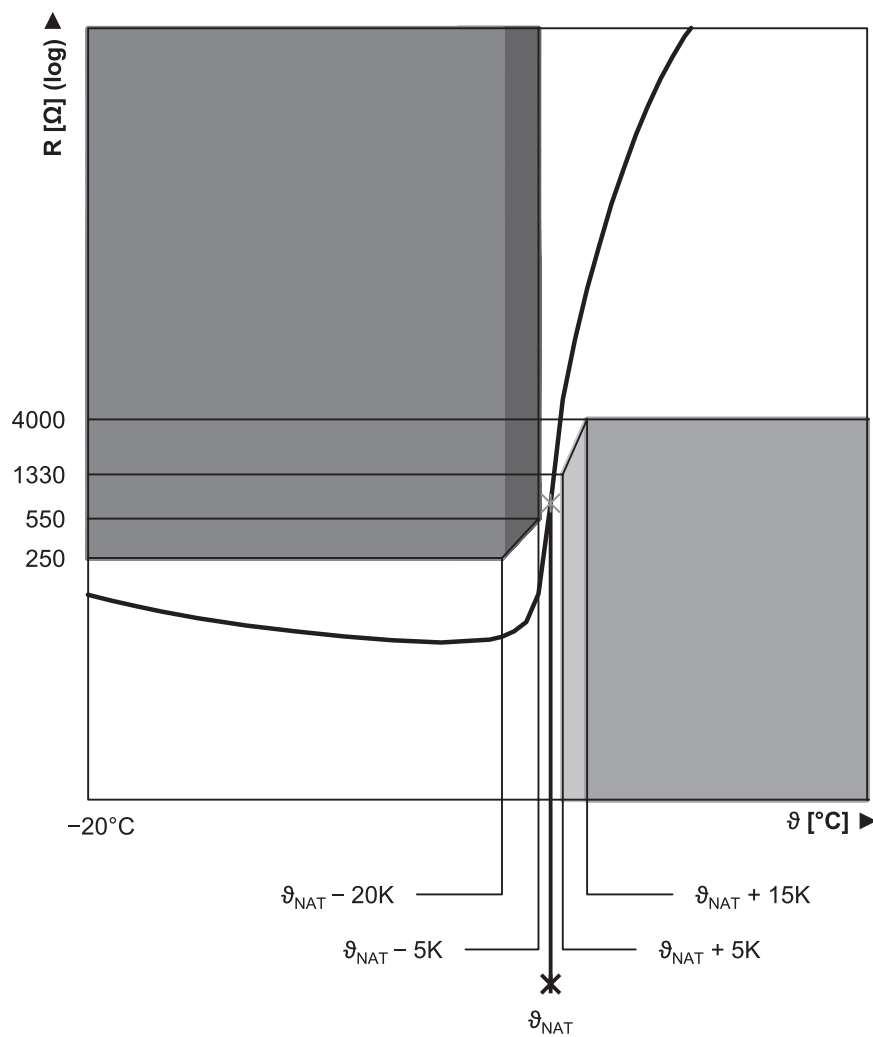

Fig. 2: PTC thermistor curve (single thermistor)

7.6.5.2 Pt1000 temperature sensor

STOBER synchronous servo motors are available in versions with a Pt1000 temperature sensor. The Pt1000 is a temperature-dependent resistor that has a resistance curve with a linear relationship with temperature. As a result, the Pt1000 allows for measurements of the winding temperature. These measurements are limited to one phase of the motor winding, however. In order to adequately protect the motor from exceeding the maximum permitted winding temperature, use a i^2t model in the drive controller to monitor the winding temperature.

Pt1000 temperature sensors can also be used with the One Cable Solution.

Avoid exceeding the specified measurement current so that the measured values are not falsified due to self-heating of the temperature sensor.

Feature	Description
Measurement current (constant)	2 mA
Resistance R for $\vartheta = 0\text{ °C}$	1000 Ω
Resistance R for $\vartheta = 80\text{ °C}$	1300 Ω
Resistance R for $\vartheta = 150\text{ °C}$	1570 Ω

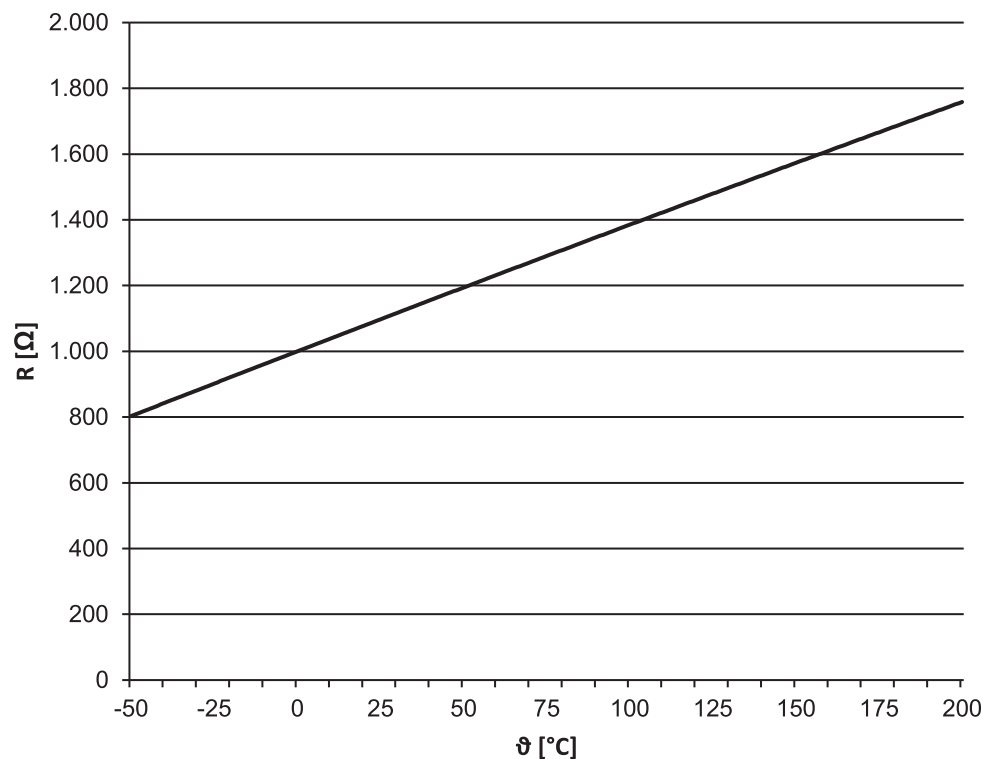

Fig. 3: Pt1000 temperature sensor characteristic curve

7.6.6 Cooling

A synchronous servo motor in the standard version is cooled by convection cooling (IC 410 in accordance with EN 60034-6). Optionally, forced ventilation can be used to cool the motor.

7.6.6.1 Forced ventilation



STOBER synchronous servo motors offer the option of being cooled with forced ventilation in order to increase performance data while maintaining the same size. Retrofitting with a forced ventilation unit is also possible in order to optimize the drive at a later date. When retrofitting, check whether the conductor cross-section of the power cable of the motor must be increased. Also take into account the dimensions of the forced ventilation unit.

The performance data for motors with forced ventilation can be found in the chapter Selection tables and the dimensions in the chapter Dimensional drawings.

Technical data

Motor	Forced ventilation unit	$U_{N,F}$ [V]	$I_{N,F}$ [A]	$P_{N,F}$ [W]	q_{VF} [m ³ /h]	$L_{pA,F}$ [dBA]	m_F [kg]	Protection class
EZ4_B	FL4	230 V ± 5%, 50/60 Hz	0.07	10	59	41	1.4	IP44
EZ5_B	FL5		0.10	14	160	45	1.9	IP54
EZ7_B	FL7		0.10	14	160	45	2.9	IP54
EZ8_B	FL8		0.20	26	420	54	5.0	IP55

Terminal assignment for forced ventilation unit plug connectors

Connection diagram	Pin	Connection
	1	L1 (phase)
	2	N (neutral conductor)
	3	
		Grounding conductor

7.6.7 Holding brake

STOBER synchronous servo motors can be equipped with a backlash-free holding brake using permanent magnets in order to secure the motor shaft when at a standstill. The holding brake engages automatically if the voltage drops.

The holding brake is designed for a high number of operations ($B_{10} = 10$ million operations, $B_{10d} = 20$ million operations).

Nominal voltage of permanent magnet holding brake: DC 24 V ± 5%, smoothed.

Observe the following during project configuration:

- The holding brake is designed to keep the motor shaft from moving. Activate braking processes during operation using the corresponding electrical functions of the drive controller. In exceptional circumstances, the holding brake can be used for braking from full speed (following a power failure or when setting up the machine). The maximum permitted work done by friction $W_{B,Rmax/h}$ may not be exceeded.
- Note that the braking torque M_{Bdyn} may initially be up to 50% less when braking from full speed. As a result, the braking effect has a delayed action and braking distances become longer.
- Regularly perform a brake test to ensure the functional safety of the brakes. Details can be found in the documentation of the motor and the drive controller.
- Connect a varistor of type S14 K35 (or comparable) in parallel to the brake coil to protect your machine from switching surges. (Not necessary for connecting the holding brake to STOBER drive controllers of the 5th and 6th generation with a BRS/BRM brake module).
- The holding brake of the motor does not offer adequate safety for persons in the hazardous area of gravity-loaded vertical axes. Therefore take additional measures to minimize risk, e.g. by providing a mechanical substructure for maintenance work.
- Take into consideration voltage losses in the connection cables that connect the voltage source to the holding brake connections.
- The holding torque of the brake can be reduced by shock loading. Information about shock loading can be found in the "Ambient conditions" chapter.
- At operating temperatures from -15 °C to 0 °C, a cold holding brake in the released state may cause operating noises. As the temperature of the holding brake increases, these noises decrease such that operating noises are not heard when using holding brake at operating temperature in the released state.

Calculation of work done by friction per braking process

$$W_{B,R/B} = \frac{J_{tot} \cdot n^2}{182.4} \cdot \frac{M_{Bdyn}}{M_{Bdyn} \pm M_L}, \quad M_{Bdyn} > M_L$$

The sign of M_L is positive if the movement runs vertically upwards or horizontally and it is negative if the movement runs vertically down.

Calculation of the stop time

$$t_{\text{dec}} = 2.66 \cdot t_{1B} + \frac{n \cdot J_{\text{tot}}}{9.55 \cdot M_{\text{Bdyn}}}$$

Switching behavior

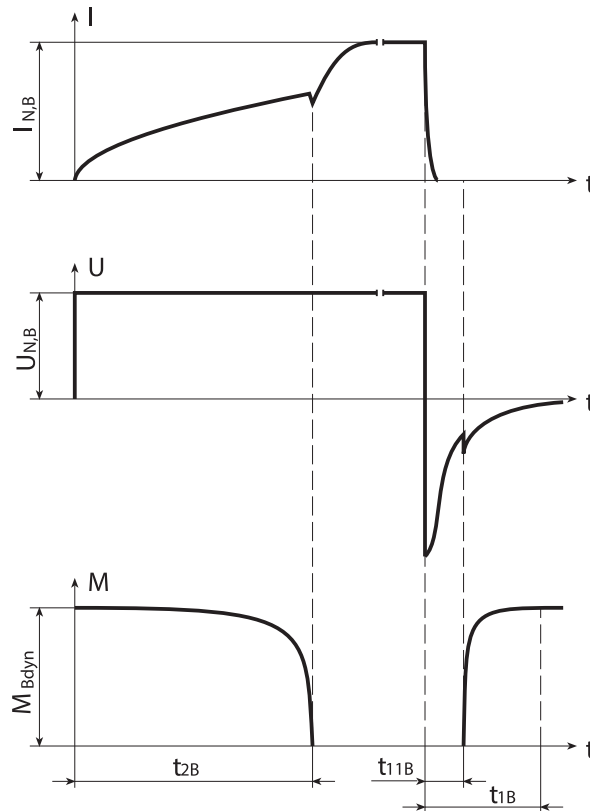

Fig. 4: Holding brake – Switching behavior

Technical data

Type	M_{Bstat} [Nm]	M_{Bdyn} [Nm]	I_{NB} [A]	$W_{B,Rmax/h}$ [kJ/h]	N_{Bstop}	J_{Bstop} [kgcm ²]	$W_{B,Rlim}$ [kJ]	t_{2B} [ms]	t_{11B} [ms]	t_{1B} [ms]	$x_{B,N}$ [mm]	ΔJ_B [kgcm ²]	Δm_B [kg]
EZ202	1.2	1.0	0.36	3.0	45000	0.310	70	10	2.0	5	0.15	0.03	0.25
EZ203	1.2	1.0	0.38	3.0	36000	0.390	70	10	2.0	5	0.15	0.03	0.25
EZ301	2.5	2.3	0.51	6.0	48000	0.752	180	25	3.0	20	0.20	0.19	0.55
EZ302	4.0	3.8	0.50	8.5	38000	0.952	180	44	4.0	26	0.30	0.19	0.55
EZ303	4.0	3.8	0.50	8.5	30000	1.17	180	44	4.0	26	0.30	0.19	0.55
EZ401	4.0	3.8	0.50	8.5	16000	2.24	180	44	4.0	26	0.30	0.19	0.76
EZ402	8.0	7.0	0.75	8.5	13500	4.39	300	40	2.0	20	0.30	0.57	0.97
EZ404	8.0	7.0	0.75	8.5	8500	7.09	300	40	2.0	20	0.30	0.57	0.97
EZ501	8.0	7.0	0.75	8.5	8700	6.94	300	40	2.0	20	0.30	0.57	1.19
EZ502	8.0	7.0	0.80	8.5	5200	11.5	300	40	2.0	20	0.30	0.57	1.19
EZ503	15	12	1.0	11.0	5900	18.6	550	60	5.0	30	0.30	1.72	1.62
EZ505	15	12	1.0	11.0	4000	27.8	550	60	5.0	30	0.30	1.72	1.62
EZ701	15	12	1.0	11.0	5400	20.5	550	60	5.0	30	0.30	1.74	1.94
EZ702	15	12	1.0	11.0	3600	30.9	550	60	5.0	30	0.30	1.74	1.94
EZ703	32	28	1.1	25.0	5200	54.6	1400	100	5.0	25	0.40	5.68	2.81
EZ705	32	28	1.1	25.0	3500	79.4	1400	100	5.0	25	0.40	5.68	2.81
EZ802	65	35	1.7	45.0	6000	149	2250	200	10	50	0.40	16.5	5.40
EZ803	65	35	1.7	45.0	4500	200	2250	200	10	50	0.40	16.5	5.40
EZ805	115	70	2.1	65.0	7000	376	6500	190	12	65	0.50	55.5	8.40

7.6.8 Connection method

The following chapters describe the connection technology of STOBBER synchronous servo motors in the standard version on STOBBER drive controllers. You can find further information relating to the drive controller type that was specified in your order in the connection plan that is delivered with every synchronous servo motor.

7.6.8.1 Connection of the motor housing to the grounding conductor system

Connect the motor housing to the grounding conductor system of the machine in order to prevent personal injury and faulty triggering of residual current protective devices.

All attachment parts required for the connection of the grounding conductor to the motor housing are delivered with the motor. The grounding screw of the motor is identified with the symbol  in accordance with IEC 60417-DB. The cross-section of the grounding conductor has to be at least as large as the cross-section of the lines in the power connection.

7.6.8.2 Plug connectors (One Cable Solution)

In the One Cable Solution design, the power and encoder lines are connected using a shared plug connector. For motors with forced ventilation, avoid collisions between the motor connection cables and the plug connector of the forced ventilation unit. In the event of a collision, turn the motor plug connectors accordingly. Details regarding the position of the plug connector for the forced ventilation unit can be found in the "Dimensional drawings" chapter.

The figures represent the position of the plug connectors upon delivery.

Turning ranges of plug connectors (EZ2 – EZ3 motors)

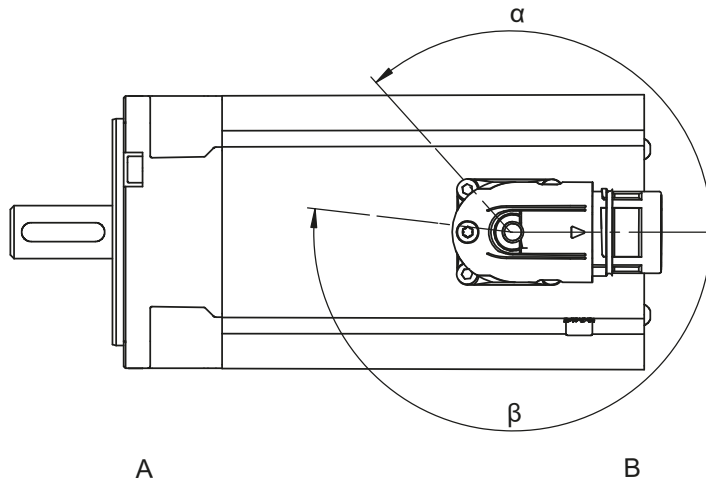

A	Attachment or output side of the motor	B	Rear side of the motor
---	----------------------------------------	---	------------------------

Turning ranges of plug connectors (EZ4 – EZ7 motors)

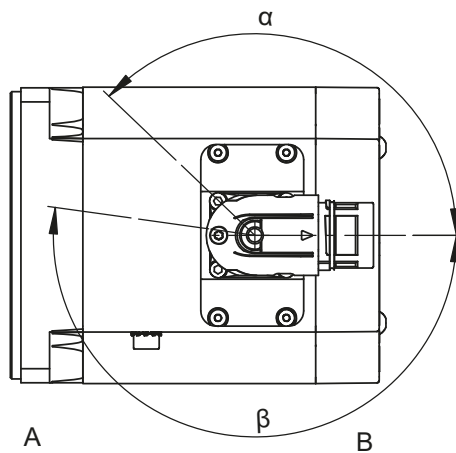

A	Attachment or output side of the motor	B	Rear side of the motor
---	----------------------------------------	---	------------------------

Plug connector features

Motor type	Size	Connection	Turning range	
			α	β
EZ2 – EZ5, EZ701 – EZ703, EZ705U	con.23	Quick lock	130°	190°

Notes

- The number after "con." indicates the approximate external thread diameter of the plug connector in mm (for example, con.23 designates a plug connector with an external thread diameter of about 23 mm).

7.6.8.3 Plug connectors

STOBER synchronous servo motors are equipped with rotatable quick-lock plug connectors in the standard version. Details can be found in this chapter.

For motors with forced ventilation, avoid collisions between the motor connection cables and the plug connector of the forced ventilation unit. In the event of a collision, turn the motor plug connectors accordingly. Details regarding the position of the plug connector for the forced ventilation unit can be found in the "Dimensional drawings" chapter.

The figures represent the position of the plug connectors upon delivery.

Turning ranges of plug connectors (EZ2 – EZ3 motors)

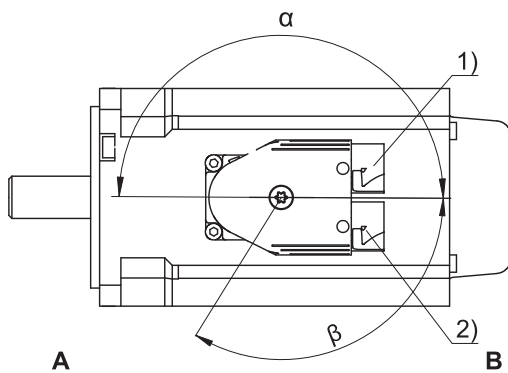

- 1 Power plug connector
- 2 Encoder plug connector
- A Attachment or output side of the motor
- B Rear side of the motor

Turning ranges of plug connectors (EZ4 – EZ8 motors)

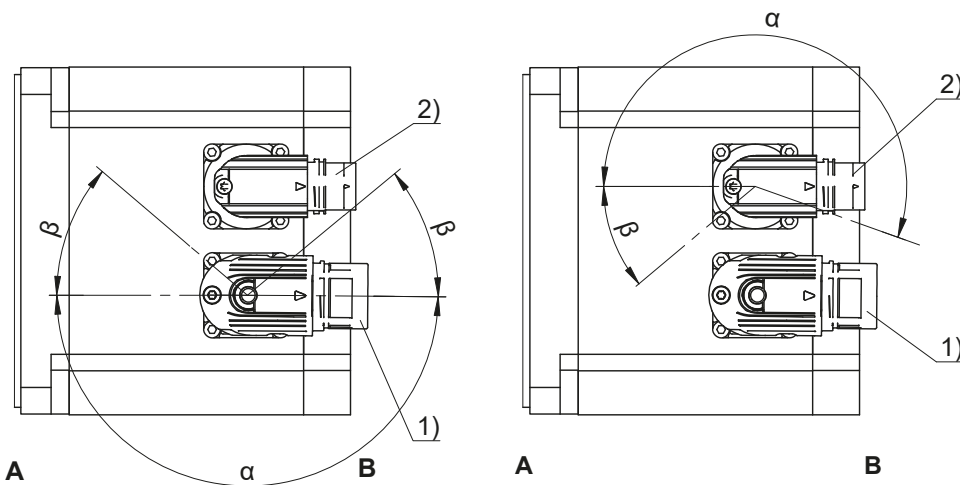

- 1 Power plug connector
- 2 Encoder plug connector
- A Attachment or output side of the motor
- B Rear side of the motor

Power plug connector features

Motor type	Size	Connection	Turning range	
			α	β
EZ2, EZ3	con.15	Quick lock	180°	140°
EZ4, EZ5, EZ701, EZ702, EZ703	con.23	Quick lock	180°	40°
EZ705, EZ802, EZ803, EZ805	con.40	Quick lock	180°	40°

Encoder plug connector features

Motor type	Size	Connection	Turning range	
			α	β
EZ2, EZ3	con.15	Quick lock	180°	140°
EZ4, EZ5, EZ7, EZ802, EZ803, EZ805	con.17	Quick lock	195°	35°

Notes

- The number after "con." indicates the approximate external thread diameter of the plug connector in mm (for example, con.23 designates a plug connector with an external thread diameter of about 23 mm).
- In turning range β , the power or encoder plug connectors can be turned only if doing so does not cause them to collide.
- For the EZ3 motor, the power and encoder plug connectors are mechanically connected and can only be turned together.

7.6.8.4 Terminal assignment for plug connectors (One Cable Solution)

In the One Cable Solution design, the power and encoder lines are connected using a shared plug connector. The temperature sensor of the motor is connected to the encoder internally. The measured values from the temperature sensor are transmitted via the EnDat 3 protocol of the encoder.

Plug connector size con.23

Connection diagram	Pin	Connection	Color
	A	U phase	BK
	B	V phase	BU
	C	W phase	RD
	E	P_SD -	YE
	F		
	G	Brake +	
	H	P_SD +	VT
	L	Brake -	
	⊕	Grounding conductor	GNYE

7.6.8.5 Connection assignment of the power plug connector

The size and connection plan of the power plug connector depend on the size of the motor. The colors of the connecting wires inside the motor are specified in accordance with IEC 60757.

Plug connector size con.15

Connection diagram	Pin	Connection	Color
	A	U phase	BK
	B	V phase	BU
	C	W phase	RD
	1	Temperature sensor +	
	2	Temperature sensor -	
	3	Brake +	RD
	4	Brake -	BK
⊕	Grounding conductor	GNYE	

Plug connector size con.23

Connection diagram	Pin	Connection	Color
	1	U phase	BK
	3	V phase	BU
	4	W phase	RD
	A	Brake +	RD
	B	Brake -	BK
	C	Temperature sensor +	
	D	Temperature sensor -	
	⊕	Grounding conductor	GNYE

Plug connector size con.40 (1.5)

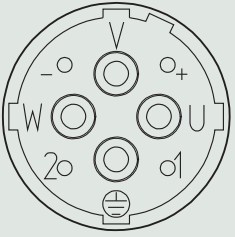
Connection diagram	Pin	Connection	Color
	U	U phase	BK
	V	V phase	BU
	W	W phase	RD
	+	Brake +	RD
	-	Brake -	BK
	1	Temperature sensor +	
	2	Temperature sensor -	
⊕	Grounding conductor	GNYE	

7.6.8.6 Connection assignment of the encoder plug connector

The size and connection assignment of the encoder plug connectors depend on the model of encoder installed and the size of the motor.

EnDat 2.1/2.2 digital encoders, plug connector size con.15

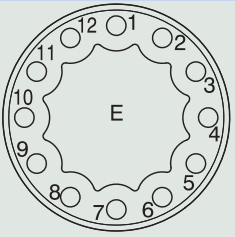
Connection diagram	Pin	Connection	Color
	1	Clock +	VT
	2	Up sense	BNGN
	3		
	4		
	5	Data -	PK
	6	Data +	GY
	7		
	8	Clock -	YE
	9		
	10	0 V GND	WHGN
	11		
	12	Up +	BNGN

EnDat 2.1/2.2 digital encoders, plug connector size con.17

Connection diagram	Pin	Connection	Color
	1	Clock +	VT
	2	Up sense	BNGN
	3		
	4		
	5	Data -	PK
	6	Data +	GY
	7		
	8	Clock -	YE
	9		
	10	0 V GND	WHGN
	11		
	12	Up +	BNGN

EnDat 2.2 digital encoder with battery buffering, plug connector size con.15

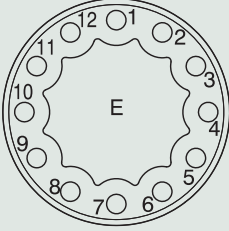
Connection diagram	Pin	Connection	Color
	1	Clock +	VT
	2	UBatt +	BU
	3	UBatt -	WH
	4		
	5	Data -	PK
	6	Data +	GY
	7		
	8	Clock -	YE
	9		
	10	0 V GND	WHGN
	11		
	12	Up +	BNGN
UBatt+ = DC 3.6 V for encoder model EBI in combination with the AES option of STOBBER drive controllers			

EnDat 2.2 digital encoder with battery buffering, plug connector size con.17

Connection diagram	Pin	Connection	Color
	1	Clock +	VT
	2	UBatt +	BU
	3	UBatt -	WH
	4		
	5	Data -	PK
	6	Data +	GY
	7		
	8	Clock -	YE
	9		
	10	0 V GND	WHGN
	11		
	12	Up +	BNGN
UBatt+ = DC 3.6 V for encoder model EBI in combination with the AES option of STOBBER drive controllers			

EnDat 2.1 encoder with sin/cos incremental signals, plug connector size con.15

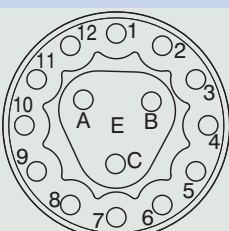
Connection diagram	Pin	Connection	Color
	1	Up sense	BU
	2	0 V sense	WH
	3	Up +	BNGN
	4	Clock +	VT
	5	Clock -	YE
	6	0 V GND	WHGN
	7	B + (Sin +)	BUBK
	8	B - (Sin -)	RDBK
	9	Data +	GY
	10	A + (Cos +)	GNBK
	11	A - (Cos -)	YEBK
	12	Data -	PK
A			
B			
C			

EnDat 2.1 encoder with sin/cos incremental signals, plug connector size con.17

Connection diagram	Pin	Connection	Color
	1	Up sense	BU
	2		
	3		
	4	0 V sense	WH
	5		
	6		
	7	Up +	BNGN
	8	Clock +	VT
	9	Clock -	YE
	10	0 V GND	WHGN
	11		
	12	B + (Sin +)	BUBK
	13	B - (Sin -)	RDBK
	14	Data +	GY
	15	A + (Cos +)	GNBK
	16	A - (Cos -)	YEBK
	17	Data -	PK

Resolver, plug connector size con.15

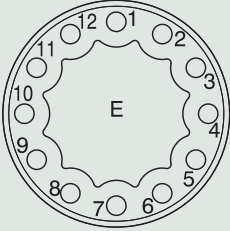
Connection diagram	Pin	Connection	Color
	1	S3 Cos +	BK
	2	S1 Cos -	RD
	3	S4 Sin +	BU
	4	S2 Sin -	YE
	5		
	6		
	7	R2 Ref +	YEWB/BKWH ²
	8	R1 Ref -	RDWH
	9		
	10		
	11		
	12		

Resolver, plug connector size con.17

Connection diagram	Pin	Connection	Color
	1	S3 Cos +	BK
	2	S1 Cos -	RD
	3	S4 Sin +	BU
	4	S2 Sin -	YE
	5		
	6		
	7	R2 Ref +	YEWB/BKWH ³
	8	R1 Ref -	RDWH
	9		
	10		
	11		
	12		

² (depending on the brand of the resolver)

³ (depending on the brand of the resolver)

7.7 Project configuration

Project your drives using our SERVOSOFT designing software. Download SERVOSOFT for free at <https://www.stoeber.de/en/ServoSoft>.

It is the most convenient and reliable method of drive selection, as the entire torque/speed curve of the application is displayed and evaluated here in the curve of the geared motor.

In this chapter, only limit values for specific operating points can be taken into consideration for manual drive selection.

An explanation of the formula symbols can be found in Chapter Symbols in formulas.

The formula symbols for values actually present in the application are marked with *.

7.7.1 Drive selection

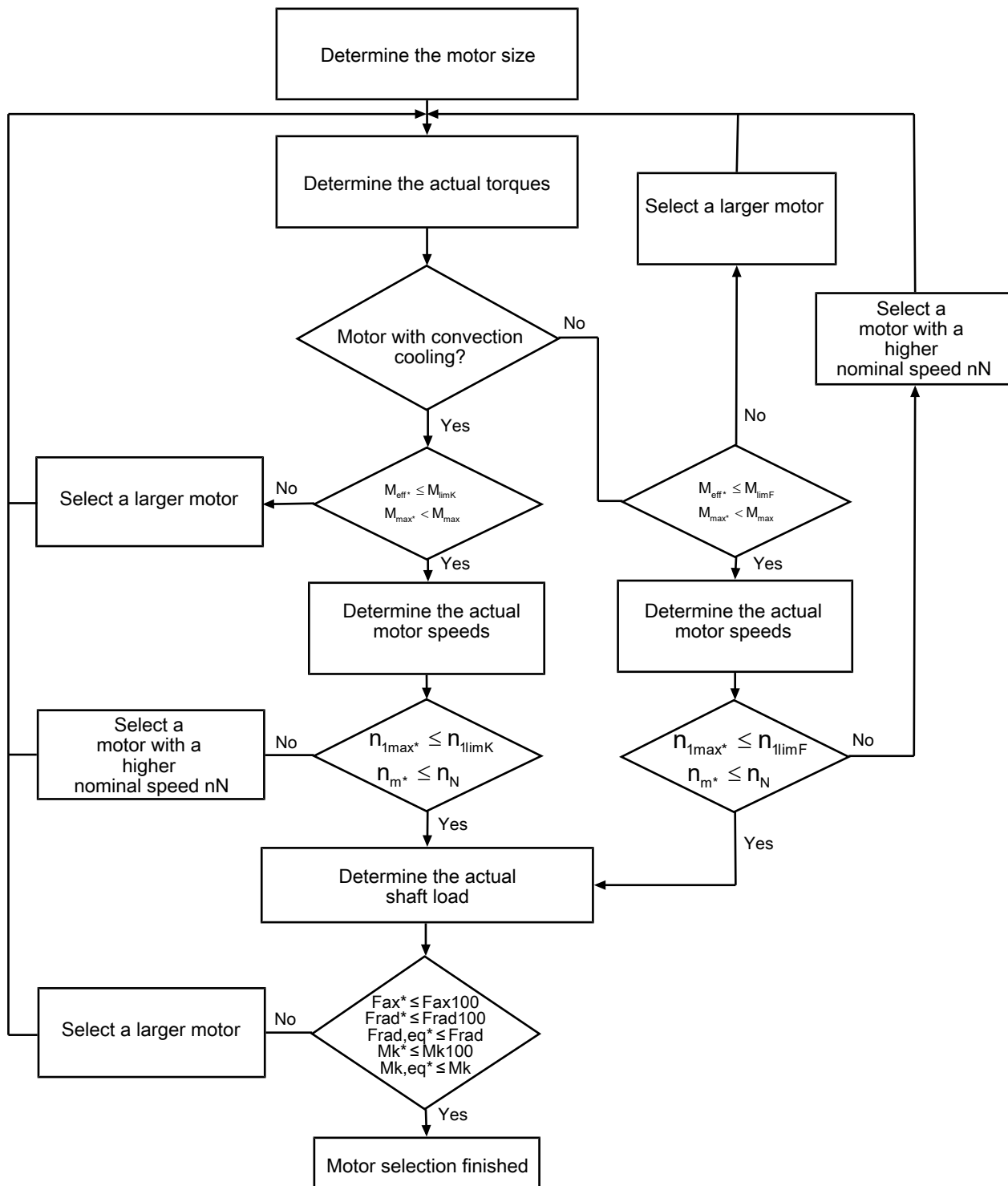

The value for M_{lim} , M_{limK} , M_{limF} , M_{max} , n_{1limK} and n_{1limF} can be found in the motor characteristic curve in the chapter [▶ 7.3]. Note the size, nominal speed n_N and cooling type of the motor.

Example of cyclic operation

The following calculations refer to a representation of the power delivered at the motor shaft in accordance with the following example:

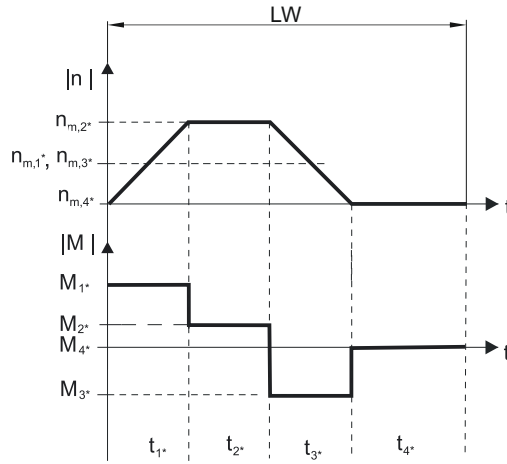

Calculation of the actual average input speed

$$n_{m*} = \frac{|n_{m,1*}| \cdot t_{1*} + \dots + |n_{m,n*}| \cdot t_{n*}}{t_{1*} + \dots + t_{n*}}$$

If $t_{1*} + \dots + t_{3*} \geq 6 \text{ min}$, determine n_{m*} without the rest phase t_{4*} .

Calculation of the actual effective torque

$$M_{eff*} = \sqrt{\frac{t_{1*} \cdot M_{1*}^2 + \dots + t_{n*} \cdot M_{n*}^2}{t_{1*} + \dots + t_{n*}}}$$

7.7.2 Permitted shaft loads

This chapter contains information about the maximum permitted shaft loads of the output shaft of the motor.

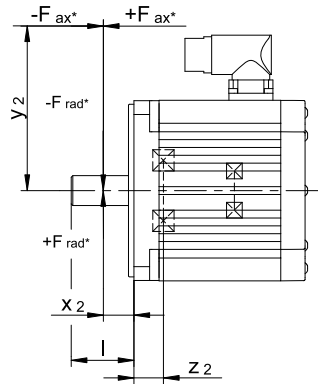

Type	z_2 [mm]	F_{ax100} [N]	F_{rad100} [N]	M_{k100} [Nm]
EZ202	12.0	250	750	20
EZ203	12.0	250	750	20
EZ301	24.0	350	1000	39
EZ302	24.0	350	1000	39
EZ303	24.0	350	1000	39
EZ401	19.5	550	1800	62
EZ402	19.5	550	1800	71
EZ404	19.5	550	1800	71
EZ501	19.5	750	2000	79
EZ502	19.5	750	2400	95
EZ503	19.5	750	2400	107
EZ505	19.5	750	2400	107
EZ701	24.5	1300	3500	173
EZ702	24.5	1300	4200	208
EZ703	24.5	1300	4200	208
EZ705	24.5	1300	4200	225
EZ802	28.5	1750	5600	384
EZ803	28.5	1750	5600	384
EZ805	28.5	1750	5600	384

The values for permitted shaft loads specified in the table apply:

- For shaft dimensions in accordance with the catalog
- A force applied at the center of the output shaft: $x_2 = l / 2$ (shaft dimensions can be found in the chapter Dimensional drawings)
- Output speeds $n_{m^*} \leq 100$ rpm ($F_{ax} = F_{ax100}$; $F_{rad} = F_{rad100}$; $M_k = M_{k100}$)

The following applies to output speeds $n_{m^*} > 100$ rpm:

$$F_{ax} = \frac{F_{ax100}}{\sqrt[3]{\frac{n_{m^*}}{100 \text{ rpm}}}} \quad F_{rad} = \frac{F_{rad100}}{\sqrt[3]{\frac{n_{m^*}}{100 \text{ rpm}}}} \quad M_k = \frac{M_{k100}}{\sqrt[3]{\frac{n_{m^*}}{100 \text{ rpm}}}}$$

The following applies to other force application points:

$$M_{k^*} = \frac{2 \cdot F_{ax^*} \cdot y_2 + F_{rad^*} \cdot (x_2 + z_2)}{1000}$$

For applications with multiple axial and/or radial forces, you must add the forces as vectors.

Also note the calculation for equivalent values:

$$M_{k,eq^*} = \sqrt[3]{\frac{|n_{m,1^*}| \cdot t_{1^*} \cdot |M_{k,1^*}|^3 + \dots + |n_{m,n^*}| \cdot t_{n^*} \cdot |M_{k,n^*}|^3}{|n_{m,1^*}| \cdot t_{1^*} + \dots + |n_{m,n^*}| \cdot t_{n^*}}}$$

$$F_{rad,eq^*} = \sqrt[3]{\frac{|n_{m,1^*}| \cdot t_{1^*} \cdot |F_{rad,1^*}|^3 + \dots + |n_{m,n^*}| \cdot t_{n^*} \cdot |F_{rad,n^*}|^3}{|n_{m,1^*}| \cdot t_{1^*} + \dots + |n_{m,n^*}| \cdot t_{n^*}}}$$

7.7.3 Derating

If you use the motor under ambient conditions that differ from the standard ambient conditions, the nominal torque M_N of the motor is reduced. In this chapter, you can find information for calculating the reduced nominal torque.

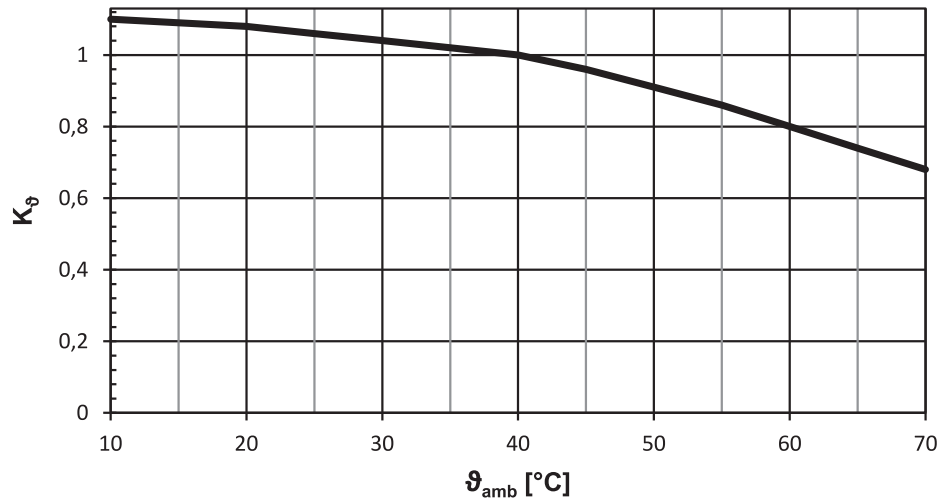

Fig. 5: Derating depending on the surrounding temperature

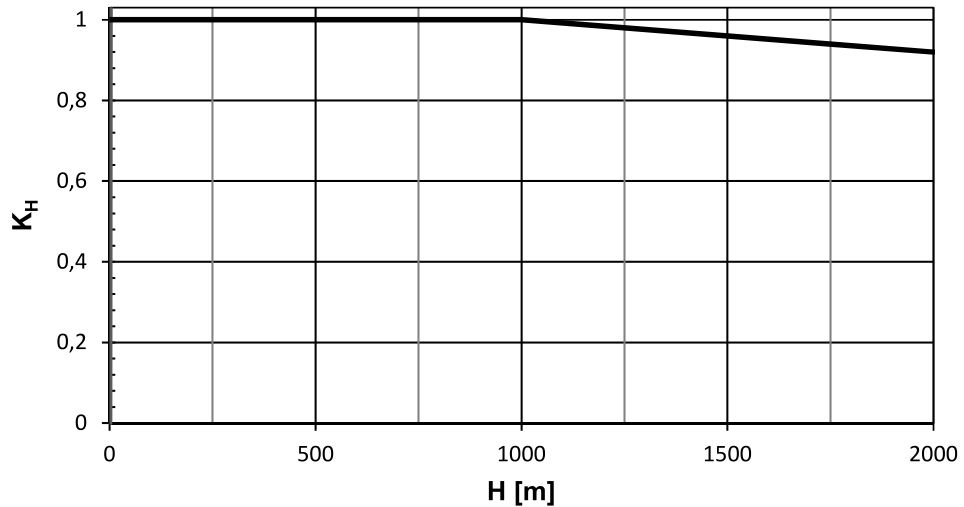

Fig. 6: Derating depending on the installation height

Calculation

If surrounding temperature $\vartheta_{amb} > 40$ °C:

$$M_{Nred} = M_N \cdot K_\phi$$

If installation altitude $H > 1000$ m above sea level:

$$M_{Nred} = M_N \cdot K_H$$

If the surrounding temperature $\vartheta_{amb} > 40$ °C and installation altitude $H > 1000$ m above sea level:

$$M_{Nred} = M_N \cdot K_H \cdot K_\phi$$

7.8 Further information

7.8.1 Directives and standards

STOBER synchronous servo motors meet the requirements of the following directives and standards:

- (Low Voltage) Directive 2014/35/EU
- EN 60034-1:2010 + Cor.:2010
- EN 60034-5:2001 + A1:2007
- EN 60034-6:1993

7.8.2 Identifiers and test symbols

STOBER synchronous servo motors have the following identifiers and test symbols:



CE mark: The product meets the requirements of EU directives.



UKCA mark: The product meets the requirements of UK directives.



cURus test symbol "Servo and Stepper Motors – Component"; registered under UL number E488992 with Underwriters Laboratories USA (optional).

7.8.3 Additional documentation

Additional documentation related to the product can be found at

<http://www.stoeber.de/en/downloads/>

Enter the ID of the documentation in the Search field.

Documentation	ID
Operating manual for EZ synchronous servo motors	443032_en



24

8

Close to customers around the world

We offer you committed, expert advice and support and are available around the clock if service is required:

- 4 sales centers in Germany
- Worldwide presence in over 40 countries
- STÖBER SERVICE NETWORK with over 80 service partners worldwide

Germany

STÖBER Antriebstechnik GmbH + Co. KG

Kieselbronner Strasse 12

75177 Pforzheim

Phone: +49 7231 582-0

sales@stoerber.de

www.stoerber.com

Service hotline: +49 7231 582-3000

Subsidiaries

STOBER AUSTRIA www.stoerber.at Phone +43 7613 7600-0 sales@stoerber.at	STOBER SOUTH EAST ASIA www.stoerber.sg sales@stoerber.sg
STOBER CHINA www.stoerber.cn Phone +86 512 5320 8850 sales@stoerber.cn	STOBER SWITZERLAND www.stoerber.ch Phone +41 56 496 96 50 sales@stoerber.ch
STOBER FRANCE www.stoerber.fr Phone +33 4 78.98.91.80 sales@stoerber.fr	STOBER TAIWAN www.stoerber.tw Phone +886 4 2358 6089 sales@stoerber.tw
STOBER ITALY www.stoerber.it Phone +39 02 93909570 sales@stoerber.it	STOBER TURKEY www.stoerber.com Phone +90 216 510 2290 sales-turkey@stoerber.com
STOBER JAPAN www.stoerber.co.jp Phone +81 3 5875 7583 sales@stoerber.co.jp	STOBER UNITED KINGDOM www.stoerber.co.uk Phone +44 1543 458 858 sales@stoerber.co.uk
STOBER USA www.stoerber.com Phone +1 606 759 5090 sales@stoerber.com	

9 Appendix

Table of contents

9.1 Symbols in formulas	234
9.2 Trademarks	237
9.3 Sales terms and delivery conditions	237
9.4 Publication details	237

9.1 Symbols in formulas

The formula symbols for values actually present in the application are marked with *.

Symbol	Unit	Explanation
B_{10}	–	Number of cycles after which 10% of components have failed
B_{10D}	–	Number of cycles until 10% of components have failed dangerously
C_{dyn}	N	Dynamic bearing load rating
C_{maxPU}	F	Maximum charging capacity of the power unit
$C_{N,PU}$	F	Nominal charging capacity of the power unit
C_{PU}	F	Self-capacitance of the power unit
D_{IA}	%	Reduction in the nominal current depending on the installation altitude
D_T	%	Reduction in the nominal current depending on the surrounding temperature
ΔJ_B	kgcm ²	Additive mass moment of inertia of a motor with brake
Δm_B	kg	Additive weight of a motor with brake
ED_{10}	%	Duty cycle based on 10 minutes
η_{gt}	%	Efficiency of the screw drive
f_{2PU}	Hz	Output frequency of the power unit
F_{ax}	N	Permitted axial force on the output
F_{ax0}	N	Permitted axial force when the motor is at a standstill for holding the load using the motor torque
$F_{ax,1*} - F_{ax,n*}$	N	Actual axial force in the respective time segment
F_{ax100}	N	Permitted axial force on the output for $n_m^* \leq 100$ rpm
F_{ax300}	N	Permitted axial force on the output for $n_m^* \leq 300$ rpm
$F_{ax,eff*}$	N	Actual effective axial force on the output
$F_{ax,ss}$	N	Axial force that can be transmitted by the shrink ring
f_N	Hz	Rotating magnetic field frequency at nominal speed
$f_{PWM,PU}$	Hz	Frequency of the pulse width modulation of the power unit
F_{rad}	N	Permitted radial force on the output
F_{rad100}	N	Permitted radial force on the output for $n_m^* \leq 100$ rpm
F_{rad300}	N	Permitted radial force on the output for $n_m^* \leq 300$ rpm
H	m	Installation altitude above sea level
I_0	A	Stall current
I_{1maxCU}	A	Maximum input current of the control unit
I_{1maxPU}	A	Maximum input current of the power unit
$I_{1N,PU}$	A	Nominal input current of the power unit
I_{2maxPU}	A	Maximum output current of the power unit
$I_{2N,PU}$	A	Nominal output current of the power unit
$I_{2N,PU(red)}$	A	Reduced nominal output current of the power unit
$I_{2PU(A)}$	A	Output current of the power unit for axis A
$I_{2PU(B)}$	A	Output current of the power unit for axis B
I_{max}	A	Maximum current
I_N	A	Nominal current
$I_{N,B}$	A	Nominal current of the brake at 20 °C
$I_{N,F}$	A	Nominal current of the forced ventilation unit
$I_{N,MF}$	A	Nominal current of the choke or motor filter
J_{Bstop}	kgcm ²	Reference mass moment of inertia when braking from full speed: $J_{Bstop} = J_{dyn} \times 2$
J_{dyn}	kgcm ²	Mass moment of inertia of a motor in dynamic operation
J_{tot}	kgm ²	Total mass moment of inertia (based on the motor shaft)
K_{EM}	V/1000 rpm	Voltage constant: peak value of the induced voltage between the phases U, V, W of the motor at operating temperature at a speed of 1000 rpm
K_H	–	Derating factor for installation altitude
K_{M0}	Nm/A	Torque constant: ratio of the stall torque and frictional torque to the stall current; $K_{M0} = (M_0 + M_r) / I_0$ (tolerance $\pm 10\%$)
$K_{M,N}$	Nm/A	Torque constant: ratio of the nominal torque M_N to the nominal current I_N ; $K_{M,N} = M_N / I_N$ (tolerance $\pm 10\%$)
$K_{mot,th}$	–	Factor for determining the thermal limit torque
K_θ	–	Derating factor for surrounding temperature

Symbol	Unit	Explanation
l	mm	Length of the output shaft
L_{10}	–	Nominal bearing service life for a survival probability of 90% in 10^6 rollovers
L_{10h}	h	Bearing service life
$L_{pA,F}$	dB(A)	Noise level of the forced ventilation unit in the optimal operating range
L_{U-V}	mH	Winding inductance of a motor between two phases (determined in a resonant circuit)
m	kg	Weight (for gear units without lubricant)
M_0	Nm	Stall torque: The continuous torque the motor is able to deliver at a speed of 10 rpm (tolerance $\pm 5\%$)
M_{Bdyn}	Nm	Dynamic braking torque at 100 °C
M_{Bstat}	Nm	Static braking torque of the motor brake at 100 °C
m_{dyn}	kg	Weight of a motor in dynamic operation
M_{eff*}	Nm	Actual effective torque of the motor
m_F	kg	Weight of the forced ventilation unit
M_k	Nm	Permitted tilting torque on the output
M_{k100}	Nm	Permitted tilting torque on the output for $n_m \leq 100$ rpm
M_{k300}	Nm	Permitted tilting torque on the output for $n_m \leq 300$ rpm
M_L	Nm	Load torque
M_{lim}	Nm	Torque limit without compensating for field weakening
M_{limF}	Nm	Torque curve of the motor with forced ventilation in continuous operation
M_{limFW}	Nm	Torque limit with compensation for field weakening (applies to operation on STOBBER drive controllers only)
M_{limK}	Nm	Torque curve of the motor with convection cooling in continuous operation
M_{max}	Nm	Maximum torque: the maximum permitted torque the motor is able to deliver over a short period (when accelerating or decelerating) (tolerance $\pm 10\%$)
M_{n*}	Nm	Actual torque of the motor in the n-th time segment
M_N	Nm	Nominal torque: the maximum torque of a motor in S1 mode at nominal speed n_N (tolerance $\pm 5\%$) You can calculate other torque values as follows: $M_{N*} = K_{M0} \cdot I^* - M_R$.
M_{Nred}	Nm	Reduced nominal torque of the motor
M_{op}	Nm	Torque of motor at the operating point from the motor characteristic curve at n_{1m*}
M_R	Nm	Frictional torque (of the bearings and seals) of a motor at winding temperature $\Delta\vartheta = 100$ K
n	rpm	Speed
n_{1m*}	rpm	Actual average input speed
n_{1max}	rpm	Maximum permitted input speed
N_{Bstop}	–	Permitted number of braking processes from full speed ($n = 3000$ rpm) with J_{Bstop} ($M_L = 0$). The following applies if the values of n and J_{Bstop} differ: $N_{Bstop} = W_{B,Rlim} / W_{B,R/B}$.
n_{m*}	rpm	Actual average motor speed
$n_{m,n*}$	rpm	Actual average speed of the motor in the n-th time segment
n_{mot}	rpm	Speed of the motor
n_N	rpm	Nominal speed: The speed for which the nominal torque M_N is specified
p	–	Number of pole pairs
P_{effRB}	W	Effective power at the external braking resistor
P_{maxRB}	W	Maximum power at the external braking resistor
P_N	kW	Nominal power: the power the motor is able to deliver long term in S1 mode at the nominal point (tolerance $\pm 5\%$)
$P_{N,F}$	W	Nominal output of the forced ventilation unit
$P_{N,PU}$	W	Nominal power of the power unit
P_{st}	mm	Pitch of the screw drive
R_{U-V}	Ω	Winding resistance of a motor between two phases at a winding temperature of 20 °C
P_V	W	Power loss
$P_{V,CU}$	W	Power loss of the control unit
q_{VF}	m ³ /h	Delivery capacity of the forced ventilation unit in open air
R_{2minRB}	Ω	Minimum resistance of the external braking resistor

Symbol	Unit	Explanation
R_{intRB}	Ω	Resistance of the internal braking resistor
$\vartheta_{\text{amb,max}}$	$^{\circ}\text{C}$	Maximum surrounding temperature
t	s	Time
t_{1B}	ms	Linking time: time from when the current is turned off until the nominal braking torque is reached
t_{11B}	ms	Response delay: time from when the current is turned off until the torque increases
t_{2B}	ms	Release time (also: disengagement time); time span from when the current is switched off until the brake is completely released
t_{dec}	ms	Stop time
T_{el}	ms	Electrical time constant: ratio of the winding inductance to the winding resistance of a motor: $T_{\text{el}} = L_{\text{U-V}} / R_{\text{U-V}}$
t_{n^*}	s	Duration of the n-th time segment
τ_{th}	$^{\circ}\text{C}$	Thermal time constant
ϑ_{amb}	$^{\circ}\text{C}$	Surrounding temperature
$U_{1\text{CU}}$	V	Input voltage of the control unit
$U_{1\text{PU}}$	V	Input voltage of the power unit
$U_{2\text{PU}}$	V	Output voltage of the power unit
$U_{2\text{PU,ZK}}$	V	Output voltage of the power unit for the DC link connection (typical values: 400 V _{AC} corresponds to 560 V _{DC} , 480 V _{AC} corresponds to 680 V _{DC})
U_{max}	V	Maximum voltage
$U_{\text{N,B}}$	V	Nominal voltage of brake
$U_{\text{N,F}}$	V	Nominal voltage of the forced ventilation unit
U_{offCH}	V	Switch-off threshold of the brake chopper
U_{onCH}	V	On limit of the brake chopper
U_{ZK}	V	DC link voltage: characteristic value of a drive controller
v_{ax}	mm/s	Axial velocity
$v_{\text{ax,m}^*}$	mm/s	Actual average axial velocity
$v_{\text{ax,m1}^*} - v_{\text{ax,mn}^*}$	mm/s	Actual average axial velocity in the respective time segment
$W_{\text{B,R/B}}$	J	Work done by friction for braking
$W_{\text{B,Rlim}}$	J	Work done by friction until wear limit is reached
$W_{\text{B,Rmax/h}}$	J/h	Maximum permitted work done by friction per hour with individual braking
x_2	mm	Distance of the shaft shoulder to the force application point
$x_{\text{B,N}}$	mm	Nominal air gap of brake
y_2	mm	Distance of the shaft axis to the axial force application point
z_2	mm	Distance of the shaft shoulder to the middle of the output bearing

9.2 Trademarks

The following names used in connection with the device, its optional equipment and its accessories are trademarks or registered trademarks of other companies:

CANopen [®] , CiA [®]	CANopen [®] and CiA [®] are registered European Union trademarks of CAN in AUTOMATION e.V., Nuremberg, Germany.
CODESYS [®]	CODESYS [®] is a registered trademark of CODESYS GmbH, Kempten, Germany.
DESINA [®]	DESINA [®] is a registered trademark of VDW Verein Deutscher Werkzeugmaschinenfabriken e. V., Frankfurt, Germany.
EnDat [®]	EnDat [®] and the EnDat [®] logo are registered trademarks of Dr. Johannes Heidenhain GmbH, Traunreut, Germany.
EtherCAT [®] , Safety over EtherCAT [®] , TwinCAT [®]	EtherCAT [®] , Safety over EtherCAT [®] and TwinCAT [®] are registered trademarks of patented technologies licensed by Beckhoff Automation GmbH, Verl, Germany.
HIPERFACE [®]	HIPERFACE [®] and the HIPERFACE DSL [®] logo are registered trademarks of SICK STEGMANN GmbH, Donaueschingen, Germany.
Intel [®] , Intel [®] Atom™, Intel [®] Core™	Intel [®] , the Intel [®] logo, Intel [®] Atom™ and Intel [®] Core™ are registered trademarks of Intel Corporation or its subsidiaries in the United States and other countries.
PLCopen [®]	PLCopen [®] is a registered trademark of the PLCopen Organisation, Gorinchem, Netherlands.
PROFIBUS [®] , PROFINET [®]	PROFIBUS [®] and PROFINET [®] are registered trademarks of PROFIBUS Nutzerorganisation e.V., Karlsruhe, Germany.
PROFIdrive [®] , PROFIsafe [®]	PROFIdrive [®] and PROFIsafe [®] are registered trademarks of Siemens AG, Munich, Germany.
RINGFEDER [®]	RINGFEDER [®] is a registered trademark of VBG GROUP TRUCK EQUIPMENT GmbH, Krefeld, Germany.
speedtec [®]	speedtec [®] is a registered trademark of TE Connectivity Industrial GmbH, Niederwinkling, Germany.
Windows [®] , Windows [®] 7, Windows [®] 10	Windows [®] , das Windows [®] -Logo, Windows [®] XP, Windows [®] 7 und Windows [®] 10 are registered trademarks of Microsoft Corporation in the United States and/or other countries.

9.3 Sales terms and delivery conditions

You can find our current sales terms and delivery conditions at <http://www.stoeber.de/en/gtc>.

9.4 Publication details

Drives and automation catalog, ID 442711_en.

You can find suitable geared motors in our Synchronous Servo Geared Motors catalog, ID 442437_en.

You can find current versions of PDF files online at <http://www.stoeber.de/en/downloads/>.

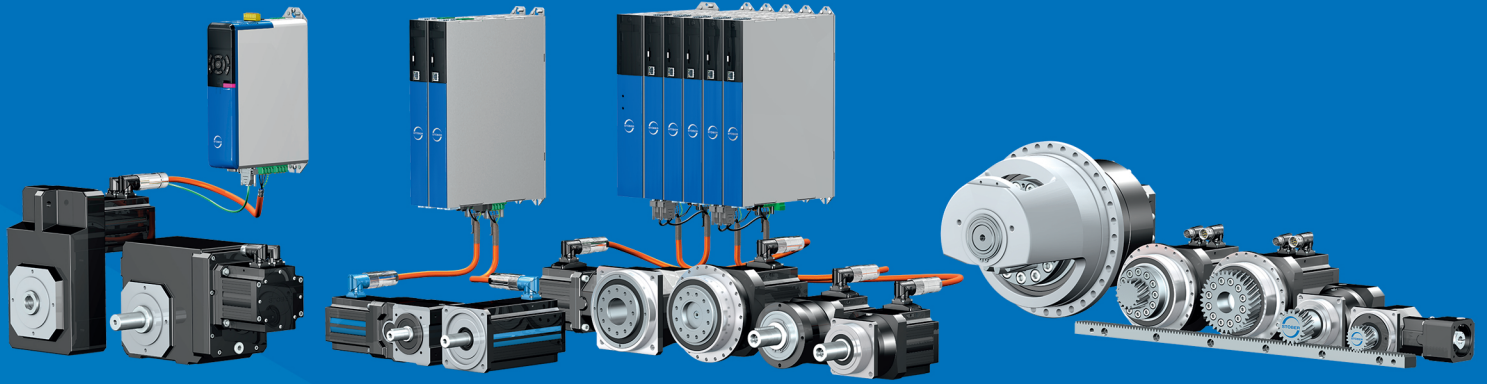

STÖBER Antriebstechnik GmbH + Co. KG
Kieselbronner Strasse 12
75177 Pforzheim
Germany
Phone: +49 7231 582-0
mail@stoeber.de
www.stoeber.com

Service hotline:
+49 7231 582-3000