

optional full stainless steel version

Permanent magnetic coupling

with collet clamps

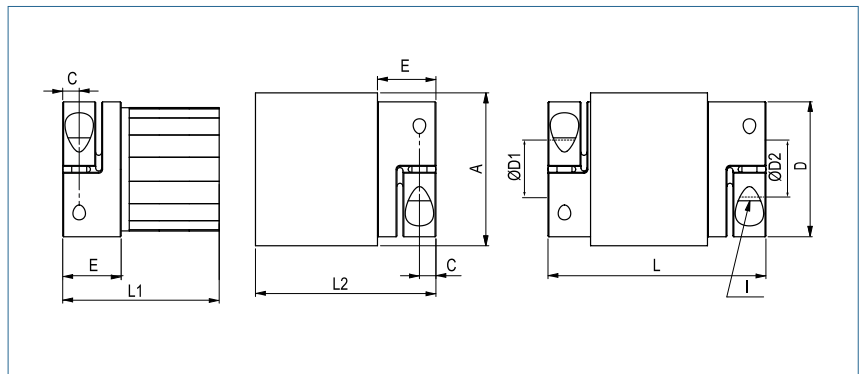
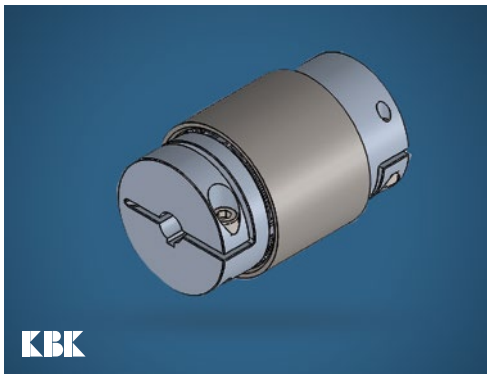

Order Code **PMK - 18 - 16 - 20**
 Type Size ØD1 (H7) ØD2 (H7)

Size	Torque TKN (Nm)	Dimensions (mm)										Technical Data						
		L Length	Ø A Outer	D1/D2 Bore Size (H7) min-max	L1	L2	H	C	E	Magnet-length	Hub Ø	I Screw (ISO4762) TA (Nm)	Mass Inner-part (kg)	Mass Outer-part (kg)	Inertia Innerpart (g m ²)	Inertia Outerpart (g m ²)	Misalignment radial ΔKr (mm)	max speed min ⁻¹
2	1.2	55	31	3-14	39	41	9	3.5	11	20	25	M3 2	0.07	0.11	0.005	0.018	0.5	10000
4	2.5	58	38	6-18	40	42	12	5	13	20	32.5	M4 3.5	0.11	0.15	0.01	0.04	0.5	9000
10	5	58	46	6-25	39.5	41.5	15.5	5	13.5	20	40.5	M4 4.5	0.16	0.2	0.04	0.08	0.5	8000
18	9	78	51	10-25.4	53.5	58.5	17	5,5	19,5	30	45	M5 8	0.23	0.28	0.07	0.14	0.5	7000
30	13	88	56	10-32	58.5	63.5	20	7,5	24.5	36	56	M6 15	0.28	0.35	0.1	0.21	0.5	6000
60	30	107	67	12-35	73	78	23	10	29	40	66	M8 40	0.53	0.7	0.3	0.6	0.5	5000
150	60	130	84	12-44	91.5	93.5	28	11	33.5	50	82	M10 84	0.9	1.5	1.1	1.3	0.4	4000

Material Clamping hub: aluminium
 Magnetic media: stainless steel

Keyway optional acc. DIN 6885

Range of temperature -30 °C ~ 100 °C

Characteristics wear-free
 maintenance-free
 The coupling consists of 2 separated halves; the bearing has to be provided by the customer
 Infinitely variable torque adjustable by immersion depth
 In case of overload the power transmission will be separated from the inner and outer part (by slightly jerking)

