



# SAFETY COUPLINGS

TORQUE LIMITERS

# KBK – The Company

## KBK Antriebstechnik GmbH - successful since 2003

Our products are based on the experience of more than 30 years in developing and producing shaft-hub-connections and backlash-free couplings combined with professional advice, service and professional competence. Our sophisticated modular design forms the basis for top quality products at reasonable prices. It enables us to produce almost all elastomer-, metal bellows-, safety couplings and line shafts as well as locking devices from the standard range within two hours, provide them with customized bores and organize a direct delivery to you by courier. Our traffic-favourable position on the edge of the Rhine-Main area simplifies the delivery to our customers all over the world. Benefit from our strenghts and our strong motivation to satisfy all our business-partners and safe time and money for your company.

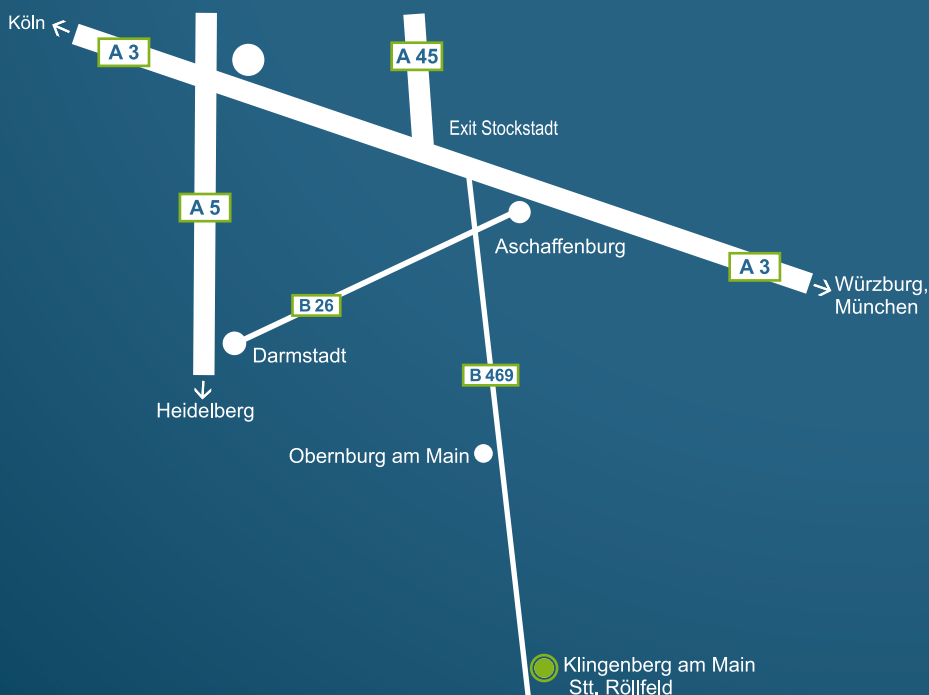

# Contents

<b>Switching Modes</b>	<b>Page 5</b>
<b>Safety Couplings with ball bearings</b>	<b>Page 6</b>
KBK/LP with keyway	Page 7
KBK/LLP with keyway	Page 8
KBK/LK with collet clamp	Page 9
KBK/LLK with collet clamp	Page 10
KBK/LI with inner cone	Page 11
KBK/LLI with inner cone	Page 12
KBK/LA with outer cone	Page 13
KBK/LLA with outer cone	Page 14
<b>Safety Couplings with bush bearings</b>	<b>Page 15</b>
KBK/CP with keyway	Page 16
KBK/CK with collet clamp	Page 17
KBK/CI with inner cone	Page 18
KBK/CA with outer cone	Page 19
<b>Safety Couplings with metal bellows</b>	<b>Page 20/21</b>
KBK/BKK with two collet clamps	Page 22
KBK/BKI with collet clamp and inner cone	Page 23
KBK/BKA with collet clamp and outer cone	Page 24
KBK/BHH with split hubs	Page 25
KBK/BKPK axial pluggable, with collet clamp (size 2 - 60)	Page 26
KBK/BKPK axial pluggable, with collet clamp (size 80 - 500)	Page 27
KBK/BKPI axial pluggable, with inner cone	Page 28
KBK/BKPA axial pluggable, with outer cone	Page 29
KBK/BIK with inner cone and collet clamp	Page 30
KBK/BII with two inner cones	Page 31
KBK/BIA with inner cone and outer cone	Page 32
KBK/BAK with outer cone and collet clamp	Page 33
KBK/BAI with outer cone and inner cone	Page 34
KBK/BAA with two outer cones	Page 35

# Contents

<b>Safety Couplings with elastomer inserts</b>	<b>Page 36/37</b>
KBK/EPP with two keyways	Page 38
KBK/EPK with keyway and collet clamp	Page 39
KBK/EPI with keyway and inner cone	Page 40
KBK/EPA with keyway and outer cone	Page 41
KBK/EKP with collet clamp and keyway	Page 42
KBK/EKK with two collet clamps	Page 43
KBK/EKI with collet clamp and inner cone	Page 44
KBK/EKA with collet clamp and outer cone	Page 45
KBK/EHH with split hubs	Page 46
KBK/EAP with outer cone and keyway	Page 47
KBK/EAK with outer cone and collet clamp	Page 48
KBK/EAI with outer cone and inner cone	Page 49
KBK/EAA with two outer cones	Page 50
<b>Spider Elements for Couplings series KBK/E</b>	<b>Page 51</b>

## Possible systems with safety couplings



### Single Position

C

When exceeding the adjusted overload torque, the coupling will disengage. After eliminating the malfunction, the coupling will re-engage automatically. This can only happen at a certain position within 360° which can be noticed on the markings of the adjusting ring and the flange.

**Note: Engagement is only possible at low speed.**



### Multi Position

D

When exceeding the adjusted overload torque, the coupling will disengage. After eliminating the malfunction, the coupling will re-engage automatically at the next successive ball points. Thus the safety coupling is immediately ready for use.

**Note: Engagement is only possible at low speed.**

Up to size 30 the angle of engagement is 45°.  
From size 60 the angle of engagement is 60°.  
Further angles of engagement upon request.



### Full Disengagement

F

When exceeding the adjusted overload torque, the coupling will disengage. The driving and driven side are permanently torque-free separated from each other. After eliminating the malfunction, the coupling can be re-engaged by applying axial pressure on the pressure ring. It might be necessary to slightly rotate the driving and driven side towards each other.

**Note: Engagement is only possible at standstill**



### Failsafe System

G

When the preset overload torque has been reached, the coupling will disengage and after a few angle degrees it will be mechanically locked. The response of the safety coupling is detected by using a limit switch and the torque flow will be stopped.

# Safety Couplings with ball bearings

## KBK|LP -10 ~ 1400

Safety Coupling  
with keyway



P. 7

## KBK|LLP -10 ~ 1400

Safety Coupling  
with keyway and two bearings



P. 8

## KBK|LK -2 ~ 500

Safety Coupling  
with collet clamp



P. 9

## KBK|LLK -2 ~ 500

Safety Coupling  
with collet clamp and two bearings



P. 10

## KBK|LI -10 ~ 1400

Safety Coupling  
with inner cone



P. 11

## KBK|LLI -10 ~ 1400

Safety Coupling  
with inner cone and two bearings



P. 12

## KBK|LA -10 ~ 1400

Safety Coupling  
with outer cone



P. 13

## KBK|LLA -10 ~ 1400

Safety Coupling  
with outer cone and two bearings



P. 14

## Safety Coupling

with keyway

optional  
nickel-plated version  
optional full stainless  
steel version

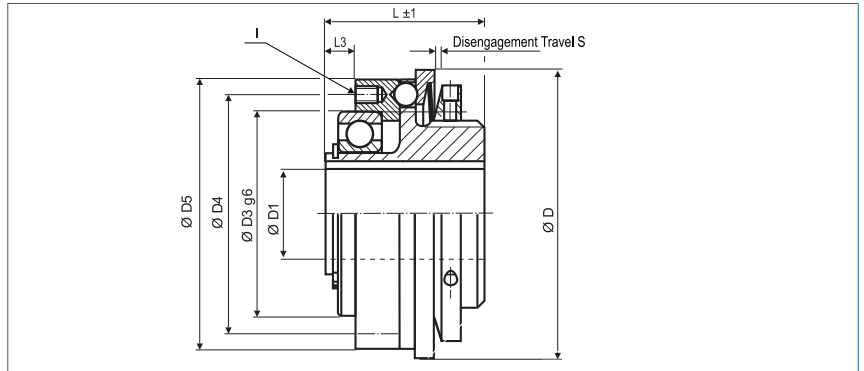

Order Code

**KBK/L-P - 60 - N20H7 - 20Nm - C or D - 2**

Type      Size      ØD1 (H7)      Disengagement Torque      Torque Range  
 C = Single Position    D = Multi Position Engagement

Size	Dimensions (mm)									Technical Data				
	ØD	Ø D1	Ø D3	Ø D4	Ø D5	L	L3	S	I	Torque Range		max. speed (1/min)	Mass (kg)	Moment of Inertia J (kg cm <sup>2</sup> )
	Outer Ø	Bore Size (H7) min~max				Length			6x	1 T <sub>KN</sub> (Nm)	2 T <sub>KN</sub> (Nm)			
-10	49	6-12	37	42	47	26	5	0.7	M3	3-7	5-10	12000	0.15	0.4
-30	64	10-16	47	53	60	33.5	6	1.2	M4	5-15	10-30	9400	0.45	1.9
-60	79	15-24	62	69	75	45	8	1.2	M5	13-35	20-65	7800	0.83	5.1
-80	94	19-29	68	80	90	46	10	2	M6	15-40	30-80	6400	1.4	12
-150	94	19-29	68	80	90	46	10	2	M6	50-130	65-150	6400	1.4	12
-200	109	20-38	80	90	105	52	10	2	M6	30-90	80-200	5500	1.64	19
-300	119	20-42	90	102	115	58	10	2	M8	60-200	100-300	5000	2.5	38
-500	129	20-50	100	112	125	57	10	2	M8	80-250	200-500	4500	3.8	68
-800	169	30-60	110	125	165	80	15	2	M12	260-600	500-900	3500	11	318
-1400	169	30-60	110	125	165	80	15	2	M12	450-900	800-1400	3500	11	318



Temperature Range -30 °C ~ 120 °C

Safety Coupling

with keyway and two bearings

optional  
nickel-plated version  
optional full stainless  
steel version

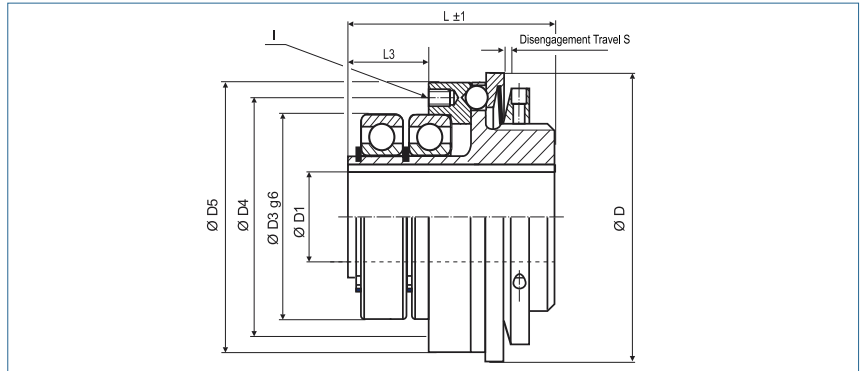

**Order Code**      **KBK/LL-P - 60 - N20H7 - 20Nm - C or D - 2**

Type                      Size                      ØD1 (H7)                      Disengagement Torque                      Torque Range

C = Single Position    D = Multi Position Engagement

Size	Dimensions (mm)									Technical Data				
	ØD	Ø D1	Ø D3	Ø D4	Ø D5	L	L3	S	I	Torque Range		max. speed (1/min)	Mass (kg)	Moment of Inertia J (kg cm <sup>2</sup> )
	Outer Ø	Bore Size (H7) min~max				Length			6x	1 T <sub>KN</sub> (Nm)	2 T <sub>KN</sub> (Nm)			
-10	49	6-12	37	42	47	36	15	0.7	M3	3-7	5-10	12000	0.18	0.4
-30	64	10-16	47	53	60	47	20	1.2	M4	5-15	10-30	9400	0.53	2.2
-60	79	15-24	62	69	75	62	26	1.2	M5	13-35	20-65	7800	0.98	6.0
-80	94	19-29	68	80	90	62	27	2	M6	15-40	30-80	6400	1.7	14
-150	94	19-29	68	80	90	62	27	2	M6	50-130	65-150	6400	1.7	14
-200	109	20-38	80	90	105	68	28	2	M6	30-90	80-200	5500	1.9	23
-300	119	20-42	90	102	115	78	31	2	M8	60-200	100-300	5000	3.0	44
-500	129	20-50	100	112	125	77	31	2	M8	80-250	200-500	4500	4.5	80
-800	169	30-60	110	125	165	103	38	2	M12	260-600	500-900	3500	13	376
-1400	169	30-60	110	125	165	103	38	2	M12	450-900	800-1400	3500	13	376

**+** Temperature Range -30 °C ~ 120 °C



## Safety Coupling

with collet clamp

optional  
nickel-plated version  
optional full stainless  
steel version

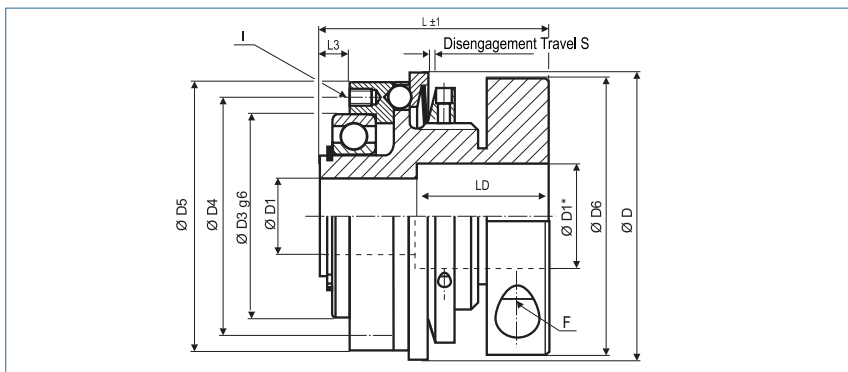

Order Code

**KBK/L-K - 60 - 20H7 - 20Nm - C or D - 2**

Type      Size      ØD1 (H7)      Disengagement Torque      Torque Range

C = Single Position    D = Multi Position Engagement

Size	Dimensions (mm)											Technical Data				
	ØD	Ø D1	Ø D3	Ø D4	Ø D5	Ø D6	L	L3	S	I	F	Torque Range		max. speed (1/min)	Mass (kg)	Moment of Inertia J (kg cm <sup>2</sup> )
	Outer Ø	Bore Size (H7) min~max					Length		6x	Screw ISO4762 T <sub>A</sub> (Nm)	1 T <sub>KN</sub> (Nm)	2 T <sub>KN</sub> (Nm)				
-2	29	3-8	19	21	25	25	28	3	0.7	M2	M3 2	0.2-1.5	0.5-2	13200	0.06	0.05
-4.5	36	6-13 9#	26	28	32	32.5	30	4	0.7	M2	M4 3.5	1-3	3-6	12300	0.11	0.20
-7	49	6-16 11#	37	42	47	40.5	36	5	0.7	M3	M4 4.5	1-4	3-7	12000	0.18	0.4
-10	49	6-16 11#	37	42	47	40.5	36	5	0.7	M3	M4 5.1	3-7	5-10	12000	0.18	0.4
-30	64	10-20 14#	47	53	60	56	52.5	6	1.2	M4	M6 15	5-15	10-30	9400	0.59	2.4
-60	79	12-28 21#	62	69	75	66	73	8	1.2	M5	M8 36	13-35	20-65	7800	1.05	6.4
-80	94	14-35 27#	68	80	90	82	67	10	2	M6	M10 84	15-40	30-80	6400	2.4	21
-150	94	14-35 27#	68	80	90	82	67	10	2	M6	M10 84	50-130	65-150	6400	2.4	21
-200	109	22-41 33#	80	90	105	90	79	10	2	M6	M12 125	30-90	80-200	5500	2.9	35
-300	119	30-50 42#	90	102	115	110	84	10	2	M8	M12 145	60-200	150-300	5000	4.4	66
-500	129	35-56 46#	100	112	125	122	95	10	2	M8	M12 145	80-250	200-500	4500	6.4	113

<b>Bore</b>	> Ø D1 and ≤ D1* only over LD
<b>Keyway</b>	optional acc. DIN 6885 biggest bore marked with a #
<b>Temperature Range</b>	-30 °C ~ 120 °C

Size	2	4.5	7	10	30	60	80	150	200	300	500
D1*	11	X	20	20	26	31	38	38	X	57	62
LD	15	X	20	20	28	38	34	34	X	42	56

## Safety Coupling

with collet clamp and two bearings

optional  
nickel-plated version  
optional full stainless  
steel version

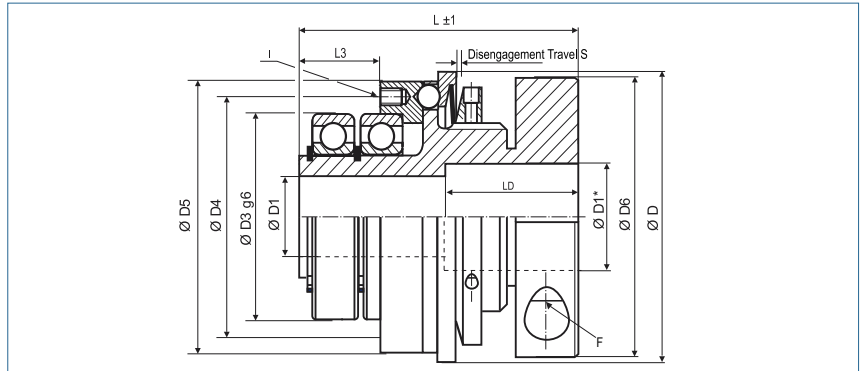

Order Code

**KBK/LL-K - 60 - 20H7 - 20Nm - C or D - 2**

Type

Size

ØD1  
(H7)

Disengagement  
Torque

Torque  
Range

C = Single Position D = Multi Position Engagement

Size	Dimensions (mm)											Technical Data				
	ØD	Ø D1	Ø D3	Ø D4	Ø D5	Ø D6	L	L3	S	I	F	Torque Range		max. speed (1/min)	Mass (kg)	Moment of Inertia J (kg cm <sup>2</sup> )
	Outer Ø	Bore Size (H7) min-max					Length		6x	Screw ISO4762 T <sub>A</sub> (Nm)	1 T <sub>KN</sub> (Nm)	2 T <sub>KN</sub> (Nm)				
-2	29	3-8	19	21	25	25	34	7	0.7	M2	M3 2	0.2-1.5	0.5-2	13200	0.07	0.06
-4.5	36	6-13 9#	26	28	32	32.5	37	9	0.7	M2	M4 3.5	1-3	3-6	12300	0.13	0.22
-7	49	6-16 11#	37	42	47	40.5	46	15	0.7	M3	M4 4.5	1-4	3-7	12000	0.21	0.5
-10	49	6-16 11#	37	42	47	40.5	46	15	0.7	M3	M4 5.1	3-7	5-10	12000	0.21	0.5
-30	64	10-20 14#	47	53	60	56	66	20	1.2	M4	M6 15	5-15	10-30	9400	0.67	2.8
-60	79	12-28 21#	62	69	75	66	90	26	1.2	M5	M8 36	13-35	20-65	7800	1.2	7.3
-80	94	14-35 27#	68	80	90	82	83	27	2	M6	M10 84	15-40	30-80	6400	2.7	23
-150	94	14-35 27#	68	80	90	82	83	27	2	M6	M10 84	50-130	65-150	6400	2.7	23
-200	109	22-41 33#	80	90	105	90	96	28	2	M6	M12 125	30-90	80-200	5500	3.3	39
-300	119	30-50 42#	90	102	115	110	104	31	2	M8	M12 145	60-200	150-300	5000	4.9	73
-500	129	35-56 46#	100	112	125	122	113	31	2	M8	M12 145	80-250	200-500	4500	7.0	125

<b>Bore</b>	> Ø D1 and ≤ D1* only over LD
<b>Keyway</b>	optional acc. DIN 6885 biggest bore marked with a #
<b>Temperature Range</b>	-30 °C ~ 120 °C

Size	2	4.5	7	10	30	60	80	150	200	300	500
D1*	11	X	20	20	26	31	38	38	X	57	62
LD	15	X	20	20	28	38	34	34	X	42	56

**Safety Coupling**

with inner cone

optional  
nickel-plated version  
optional full stainless  
steel version

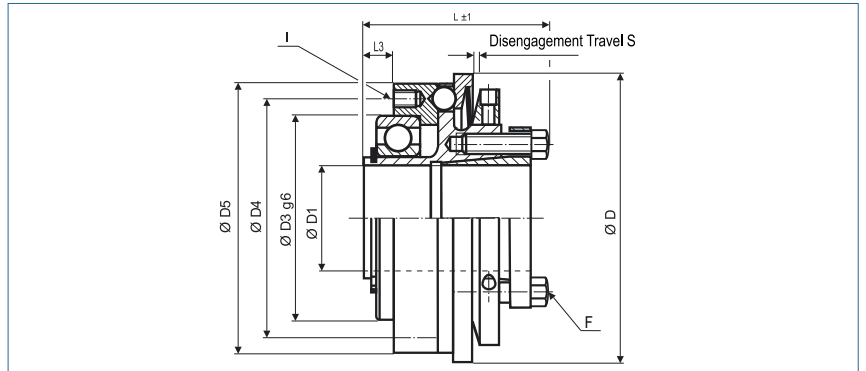

**Order Code**    **KBK/L-I - 60**    -    **20H7**    -    **20Nm**    -    **C**    or    **D**    -    **2**

Type                      Size                                      ØD1 (H)                                      Disengagement Torque                                      Torque Range  
 C = Single Position    D = Multi Position Engagement

Size	Dimensions (mm)										Technical Data				
	ØD	Ø D1	Ø D3	Ø D4	Ø D5	L	L3	S	I	F	Torque Range		max. speed (1/min)	Mass (kg)	Moment of Inertia J (kg cm <sup>2</sup> )
	Outer Ø	Bore Size (H7) min~max				Length			6x	Screw ISO4017 T <sub>A</sub> (Nm)	1 T <sub>KN</sub> (Nm)	2 T <sub>KN</sub> (Nm)			
-10	49	6-14 10#	37	42	47	36	5	0.7	M3	M3 2.1	3-7	5-10	12000	0.18	0.4
-30	64	12-20 14#	47	53	60	45	6	1.2	M4	M5 6	5-15	10-30	9400	0.54	2.2
-60	79	15-25 18#	62	69	75	58	8	1.2	M5	M6 8.5	13-35	20-65	7800	1.01	6.2
-80	94	20-35 27#	68	80	90	60	10	2	M6	M6 14	15-40	30-80	6400	1.72	15
-150	94	20-35 27#	68	80	90	60	10	2	M6	M6 14	50-130	65-150	6400	1.72	15
-200	109	20-40 32#	80	90	105	66	10	2	M6	M6 14	30-90	80-200	5500	2	24
-300	119	25-45 37#	90	102	115	75	10	2	M8	M8 20	60-200	150-300	5000	3.3	49
-500	129	35-55 45#	100	112	125	75	10	2	M8	M8 26	80-250	200-500	4500	4.7	83
-800	169	50-70 58#	110	125	165	110	15	2	M12	M16 45	260-600	500-900	3500	13.1	380
-1400	169	50-70 58#	110	125	165	110	15	2	M12	M16 80	450-900	800-1400	3500	13.2	385

**+** **Keyway**                      optional acc. DIN 6885  
    biggest bore marked with a #

**Temperature Range**    -30 °C ~ 120 °C

### Safety Coupling

with inner cone and two bearings

optional  
nickel-plated version  
optional full stainless  
steel version

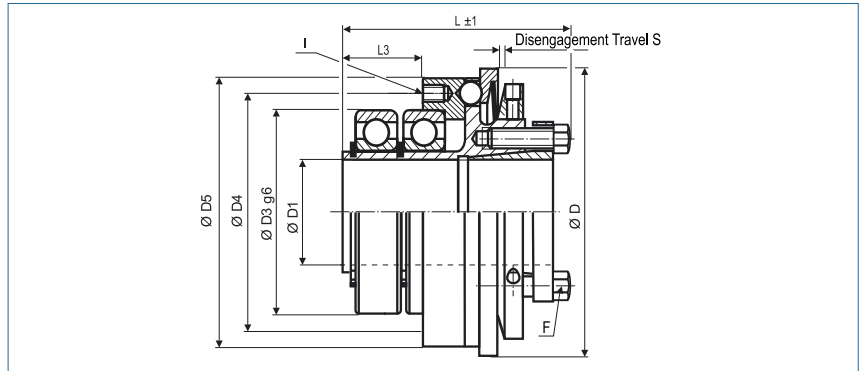
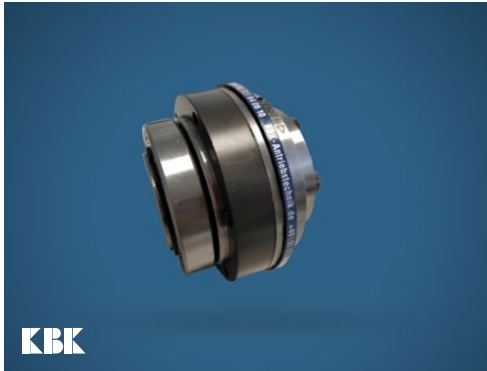

**Order Code**    **KBK/LL-I - 60 - 20H7 - 20Nm - C or D - 2**

Type                      Size                      ØD1 (H7)                      Disengagement Torque                      Torque Range

C = Single Position    D = Multi Position Engagement

Size	Dimensions (mm)										Technical Data				
	ØD Outer Ø	Ø D1 Bore Size (H7) min-max	Ø D3	Ø D4	Ø D5	L Length	L3	S	I 6x	F Screw (ISO4017) T <sub>A</sub> (Nm)	Torque Range		max. speed (1/min)	Mass (kg)	Moment of Inertia J (kg cm <sup>2</sup> )
											1 T <sub>KN</sub> (Nm)	2 T <sub>KN</sub> (Nm)			
-10	49	6-14 10#	37	42	47	46	15	0.7	M3	M3 2.1	3-7	5-10	12000	0.21	0.5
-30	64	12-20 14#	47	53	60	58	20	1.2	M4	M5 6	5-15	10-30	9400	0.62	2.6
-60	79	15-25 18#	62	69	75	75	26	1.2	M5	M6 8.5	13-35	20-65	7800	1.16	7.1
-80	94	20-35 27#	68	80	90	76	27	2	M6	M6 14	15-40	30-80	6400	1.97	17
-150	94	20-35 27#	68	80	90	76	27	2	M6	M6 14	50-130	65-150	6400	1.97	17
-200	109	20-40 32#	80	90	105	85	28	2	M6	M6 14	30-90	80-200	5500	2.30	27
-300	119	25-45 37#	90	102	115	95	31	2	M8	M8 20	60-200	150-300	5000	3.7	56
-500	129	35-55 45	100	112	125	95	31	2	M8	M8 26	80-250	200-500	4500	5.3	95
-800	169	50-70 58#	110	125	165	133	38	2	M12	M16 45	260-600	500-900	3500	15	438
-1400	169	50-70 58#	110	125	165	133	38	2	M12	M16 80	450-900	800-1400	3500	15	438

**+** **Keyway**                      optional acc. DIN 6885  
   biggest bore marked with a #

**Temperature Range**        -30 °C ~ 120 °C

## Safety Coupling

with outer cone

optional  
nickel-plated version  
optional full stainless  
steel version

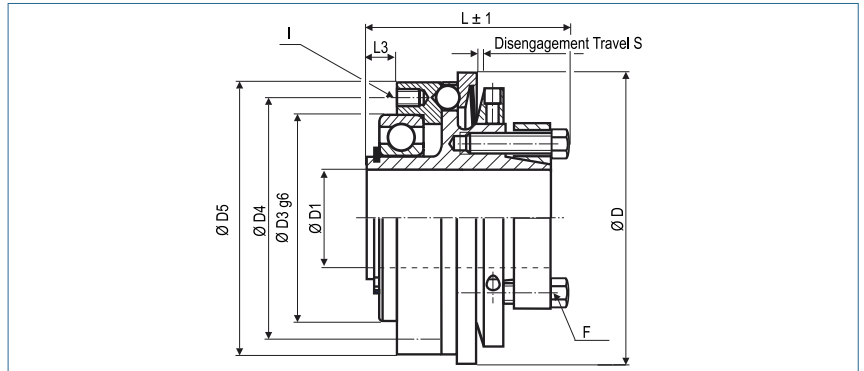

Order Code

**KBK/L-A - 60 - 20H7 - 20Nm - C or D - 2**

Type      Size      ØD1 (H7)      Disengagement Torque      Torque Range

C = Single Position    D = Multi Position Engagement

Size	Dimensions (mm)										Technical Data				
	ØD	Ø D1	Ø D3	Ø D4	Ø D5	L	L3	S	I	F	Torque Range		max. speed (1/min)	Mass (kg)	Moment of Inertia J (kg cm <sup>2</sup> )
	Outer Ø	Bore Size (H7) min-max				Length			6x	Screw ISO4017 T <sub>A</sub> (Nm)	1 T <sub>KN</sub> (Nm)	2 T <sub>KN</sub> (Nm)			
-10	49	5-12 10#	37	42	47	37.5	5	0.7	M3	M3 2.1	3-7	5-10	12000	0.18	0.4
-30	64	12-20 14#	47	53	60	48	6	1.2	M4	M5 5.9	5-15	10-30	9400	0.54	2.2
-60	79	15-25 18#	62	69	75	66	8	1.2	M5	M5 8.7	13-35	20-65	7800	1.01	6.2
-80	94	20-35 27#	68	80	90	68.5	10	2	M6	M6 15	15-40	30-80	6400	1.72	15
-150	94	20-35 27#	68	80	90	68.5	10	2	M6	M6 15	50-130	65-150	6400	1.72	15
-200	109	20-42 34#	80	90	105	74.5	10	2	M6	M6 15	30-90	80-200	5500	2	24
-300	119	25-50 42#	90	102	115	83.5	10	2	M8	M8 25	60-200	150-300	5000	3.3	49
-500	129	35-55 45#	100	112	125	89	10	2	M8	M8 36	80-250	200-500	4500	4.7	83
-800	169	50-70 58#	110	125	165	118	15	2	M12	M12 85	260-600	500-900	3500	13.1	380
-1400	169	50-70 58#	110	125	165	118	15	2	M12	M12 115	450-900	800-1400	3500	13.2	385



**Keyway**      optional acc. DIN 6885  
biggest bore marked with a #

**Temperature Range**    -30 °C ~ 120 °C

Safety Coupling

with outer cone and two bearings

optional  
nickel-plated version  
optional full stainless  
steel version

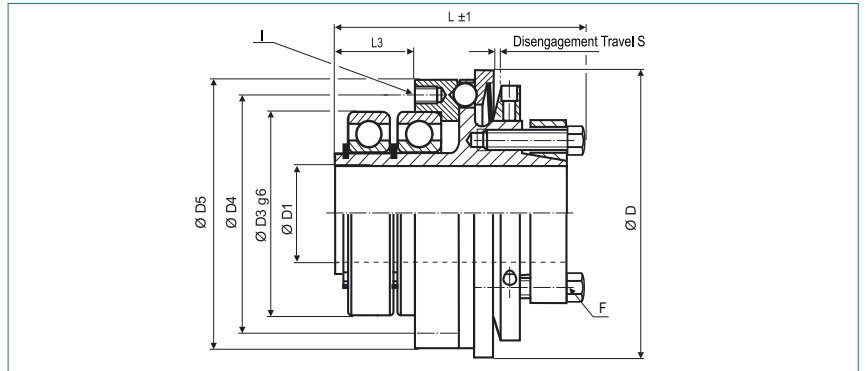

Order Code

**KBK/LL-A - 60 - 20H7 - 20Nm - C or D - 2**

Type

Size

ØD1  
(H7)

Disengagement  
Torque

Torque  
Range

C = Single Position D = Multi Position Engagement

Size	Dimensions (mm)										Technical Data				
	ØD	Ø D1	Ø D3	Ø D4	Ø D5	L	L3	S	I	F	Torque Range		max. speed (1/min)	Mass (kg)	Moment of Inertia J (kg cm <sup>2</sup> )
	Outer Ø	Bore Size (H7) min~max				Length		6x	Screw ISO4017 T <sub>A</sub> (Nm)	1 T <sub>KN</sub> (Nm)	2 T <sub>KN</sub> (Nm)				
-10	49	5-12 10#	37	42	47	47.5	15	0.7	M3	M3 2.1	3-7	5-10	12000	0.21	0.5
-30	64	12-20 14#	47	53	60	61.5	20	1.2	M4	M5 5.9	5-15	10-30	9400	0.62	2.6
-60	79	15-25 18#	62	69	75	83	26	1.2	M5	M5 8.7	13-35	20-65	7800	1.16	7.1
-80	94	20-35 27#	68	80	90	84.5	27	2	M6	M6 15	15-40	30-80	6400	1.97	17
-150	94	20-35 27#	68	80	90	84.5	27	2	M6	M6 15	50-130	65-150	6400	1.97	17
-200	109	20-42 34#	80	90	105	93.5	28	2	M6	M6 15	30-90	80-200	5500	2.30	27
-300	119	25-50 42#	90	102	115	103.5	31	2	M8	M8 25	60-200	150-300	5000	3.7	56
-500	129	35-55 45#	100	112	125	109	31	2	M8	M8 36	80-250	200-500	4500	5.3	95
-800	169	50-70 58#	110	125	165	141	38	2	M12	M12 85	260-600	500-900	3500	15	438
-1400	169	50-70 58#	110	125	165	141	38	2	M12	M12 115	450-900	800-1400	3500	15	438



Keyway

optional acc. DIN 6885

biggest bore marked with a #

Temperature Range

-30 °C ~ 120 °C

# Safety Couplings with bush bearings

## KBK|CP -10 ~ 500

Safety Coupling  
with keyway



P. 16

## KBK|CK -2 ~ 500

Safety Coupling  
with collet clamp



P. 17

## KBK|CI -10 ~ 500

Safety Coupling  
with inner cone



P. 18

## KBK|CA -10 ~ 500

Safety Coupling  
with outer cone



P. 19

### Safety Coupling

with keyway

optional  
nickel-plated version  
optional full stainless  
steel version

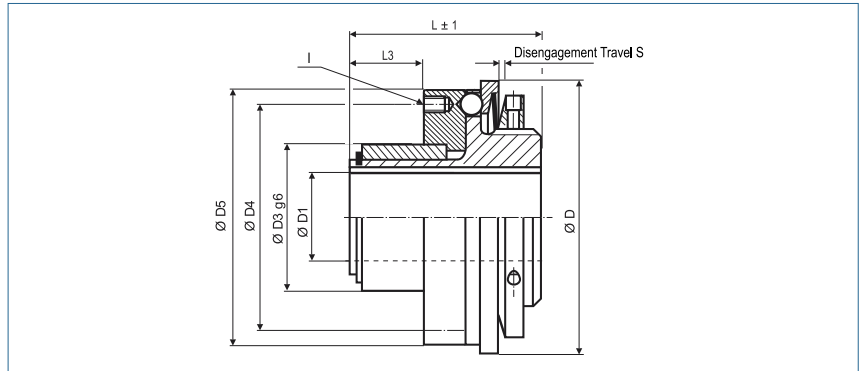

Order Code

**KBK/CP - 60 - N20H7 - 20Nm - C or D - 2**

Type

Size

ØD1  
(H7)

Disengagement  
Torque

Torque  
Range

C = Single Position D = Multi Position Engagement

Size	Dimensions (mm)									Technical Data				
	ØD	Ø D1	Ø D3	Ø D4	Ø D5	L	L3	S	I	Torque Range		max. speed (1/min)	Mass (kg)	Moment of Inertia J (kg cm <sup>2</sup> )
	Outer Ø	Bore Size (H7) min~max				Length			6x	1 TKN (Nm)	2 TKN (Nm)			
-10	49	6-10	24	30	47	34	8	0.7	M3	3-7	5-10	12000	0.15	0.35
-30	64	10-14	30	46	60	40	9	1.2	M4	5-15	10-30	9400	0.45	1.9
-60	79	15-19	36	50	75	48	16	1.2	M5	13-35	20-65	7800	0.83	5.1
-80	94	19-30	48	65	90	58	22	2	M6	15-40	30-80	6400	1.4	12
-150	94	19-30	48	65	90	58	22	2	M6	50-130	65-150	6400	1.4	12
-200	109	20-33	52	70	105	63	25	2	M6	30-90	80-200	5500	1.64	19
-300	119	20-38	58	76	115	75	31	2	M8	60-200	150-300	5000	2.5	38
-500	129	20-42	66	110	125	94	33	2	M8	80-250	200-500	4500	3.8	68



Temperature Range -30 °C ~ 120 °C



## Safety Coupling

with collet clamp

optional  
nickel-plated version  
optional full stainless  
steel version

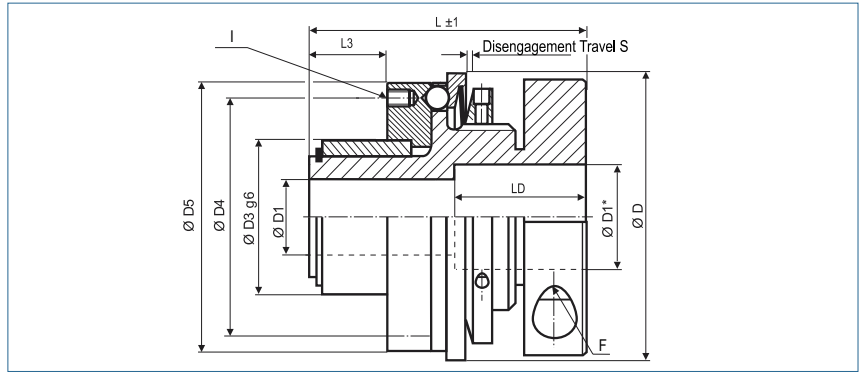

Order Code

**KBK/CK - 60 - 20H7 - 20Nm - C or D - 2**

Type      Size      ØD1 (H7)      Disengagement Torque      Torque Range

C = Single Position    D = Multi Position Engagement

Size	Dimensions (mm)										Technical Data				
	ØD	Ø D1	Ø D3	Ø D4	Ø D5	L	L3	S	I	F	Torque Range		max. speed (1/min)	Mass (kg)	Moment of Inertia J (kg cm²)
	Outer Ø	Bore Size (H7) min-max				Length			6x	Screw ISO4762 TA (Nm)	1 TKN (Nm)	2 TKN (Nm)			
-2	29	3-6	14	19	25	35	6	0.7	M2	M3 2	0.2-1.5	0.5-2	13200	0.06	0.05
-4.5	36	6-12 8#	20	26	32	36	7	0.7	M2	M4 3.5	1-3	3-6	12300	0.12	0.20
-7	49	6-16 11#	24	30	47	44	8	0.7	M3	M4 5.1	1-4	3-7	12000	0.18	0.4
-10	49	6-16 11#	24	30	47	44	8	0.7	M3	M4 5.1	3-7	5-10	12000	0.18	0.4
-30	64	10-20 14#	30	46	60	59	9	1.2	M4	M6 15	5-15	10-30	9400	0.59	2.4
-60	79	12-25 18#	36	50	75	76	16	1.2	M5	M8 36	13-35	20-65	7800	1.05	6.4
-80	94	14-35 27#	48	65	90	79	22	2	M6	M10 84	15-40	30-80	6400	2.4	21
-150	94	14-35 27#	48	65	90	79	22	2	M6	M10 84	50-130	65-150	6400	2.4	21
-200	109	22-40 32#	52	70	105	91	25	2	M6	M12 125	30-90	80-200	5500	3.0	35
-300	119	30-46 38#	58	76	115	101	31	2	M8	M12 145	60-200	150-300	5000	4.4	66
-500	129	35-50 41#	66	110	125	134	33	2	M8	M12 145	80-250	200-500	4500	6.4	113

<b>Bore</b>	> Ø D1 and ≤ D1* only over LD
<b>Keyway</b>	optional acc. DIN 6885 biggest bore marked with a #
<b>Temperature Range</b>	-30 °C ~ 120 °C

Size	2	45	7	10	30	60	80	150	200	300	500
<b>D1*</b>	11	X	20	20	26	31	38	38	X	57	62
<b>LD</b>	15	X	20	20	28	38	34	34	X	42	56

## Safety Coupling

with inner cone

optional  
nickel-plated version  
optional full stainless  
steel version

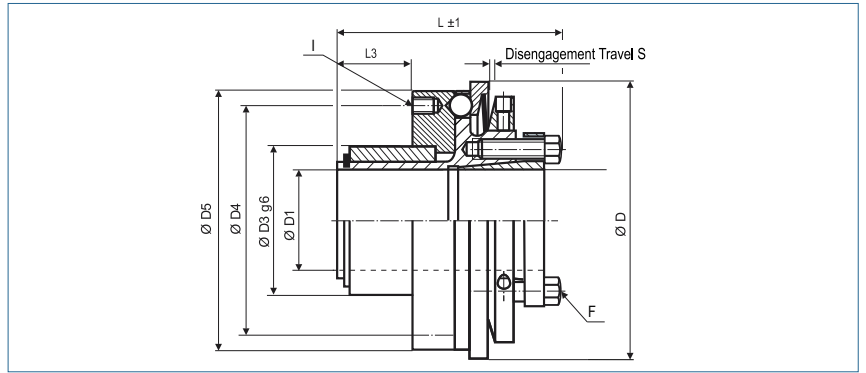

Order Code

**KBK/CI - 60 - 20H7 - 20Nm - C or D - 2**

Type

Size

ØD1  
(H7)

Disengagement  
Torque

Torque  
Range

C = Single Position D = Multi Position Engagement

Size	Dimensions (mm)										Technical Data				
	ØD	Ø D1	Ø D3	Ø D4	Ø D5	L	L3	S	I	F	Torque Range		max. speed (1/min)	Mass (kg)	Moment of Inertia J (kg cm <sup>2</sup> )
	Outer Ø	Bore Size (H7) min-max				Length			6x	Screw ISO4017 TA (Nm)	1 TKN (Nm)	2 TKN (Nm)			
-10	49	6-14 10#	24	30	47	44	8	0.7	M3	M3 2.1	3-7	5-10	12000	0.18	0.4
-30	64	12-20 14#	30	46	60	51	9	1.2	M4	M5 6	5-15	10-30	9400	0.54	2.2
-60	79	15-25 18#	36	50	75	61	16	1.2	M5	M6 8.5	13-35	20-65	7800	1	6.2
-80	94	20-35 27#	48	65	90	72	22	2	M6	M6 14	15-40	30-80	6400	1.7	15
-150	94	20-35 27#	48	65	90	72	22	2	M6	M6 14	50-130	65-150	6400	1.7	15
-200	109	20-40 32#	52	70	105	77	25	2	M6	M6 14	30-90	80-200	5500	2	24
-300	119	25-46 38#	58	76	115	93	31	2	M8	M8 20	60-200	150-300	5000	3.3	49
-500	129	35-50 41#	66	110	125	112	33	2	M8	M8 26	80-250	200-500	4500	4.7	83



**Keyway**

optional acc. DIN 6885

biggest bore marked with a #

**Temperature Range**

-30 °C ~ 120 °C

Safety Coupling

with outer cone

optional  
nickel-plated version  
optional full stainless  
steel version

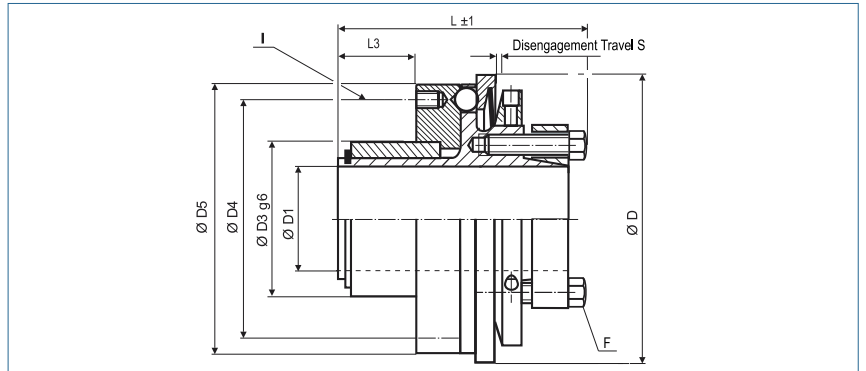

Order Code

**KBK/CA - 60 - 20H7 - 20Nm - C or D - 2**

Type

Size

ØD1  
(H7)

Disengagement  
Torque

Torque  
Range

C = Single Position D = Multi Position Engagement

Size	Dimensions (mm)										Technical Data				
	ØD	Ø D1	Ø D3	Ø D4	Ø D5	L	L3	S	I	F	Torque Range		max. speed (1/min)	Mass (kg)	Moment of Inertia J (kg cm <sup>2</sup> )
	Outer Ø	Bore Size (H7) min~max				Length			6x	Screw ISO4017 TA (Nm)	1 TKN (Nm)	2 TKN (Nm)			
-10	49	5-14 8#	24	30	47	46	8	0.7	M3	M3 2.1	3-7	5-10	12000	0.18	0.4
-30	64	12-20 14#	30	46	60	54	9	1.2	M4	M5 5.9	5-15	10-30	9400	0.53	2.2
-60	79	15-25 18#	36	50	75	69	16	1.2	M5	M5 8.7	13-35	20-65	7800	1	6.1
-80	94	20-35 27#	48	65	90	80	22	2	M6	M6 15	15-40	30-80	6400	1.8	16
-150	94	20-35 27#	48	65	90	80	22	2	M6	M6 15	50-130	65-150	6400	1.8	16
-200	109	20-40 32#	52	70	105	85	25	2	M6	M6 15	30-90	80-200	5500	2	24
-300	119	25-46 38#	58	76	115	101	31	2	M8	M8 25	60-200	150-300	5000	3.2	47
-500	129	35-50 41#	66	110	125	126	33	2	M8	M8 36	80-250	200-500	4500	4.7	84



**Keyway** optional acc. DIN 6885  
biggest bore marked with a #

**Temperature Range** -30 °C ~ 120 °C

# Safety Couplings with metal bellows

## KBK|BKK -2 ~ 500

Safety Coupling  
with collet clamp



P. 22

## KBK|BKI -10 ~ 500

Safety Coupling  
with collet clamp and inner cone



P. 23

## KBK|BKA -10 ~ 500

Safety Coupling  
with collet clamp and outer cone



P. 24

## KBK|BHH -10 ~ 500

Safety Coupling  
with split hubs



P. 25

## KBK|BKPK -2 ~ 60

Safety Coupling  
axial pluggable, with collet clamp



P. 26

## KBK|BKPK -80 ~ 500

Safety Coupling  
axial pluggable, with collet clamp



P. 27

## KBK|BKPI -10 ~ 500

Safety Coupling  
axial pluggable, with inner cone



P. 28

## KBK|BKPA -10 ~ 500

Safety Coupling  
axial pluggable, with outer cone



P. 29

## KBK|BIK -10 ~ 500

Safety Coupling  
with inner cone and collet clamp



P. 30

## KBK|BII -10 ~ 1400

Safety Coupling  
with two inner cones



P. 31

## KBK|BIA -10 ~ 1400

Safety Coupling  
with inner cone and outer cone



P. 32

## KBK|BAK -10 ~ 500

Safety Coupling  
with outer cone and collet clamp



P. 33

# Safety Couplings with metal bellows

## KBK|BAI -10 ~ 1400

Safety Coupling  
with outer cone and inner cone



P. 34

## KBK|BAA -10 ~ 1400

Safety Coupling  
with two outer cones



P. 35

## Safety Coupling

with collet clamp

optional  
nickel-plated version  
optional full stainless  
steel version

optional  
laserwelded

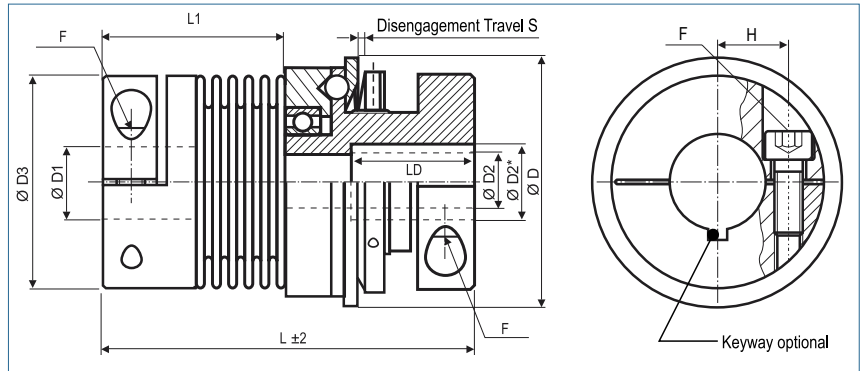

Order Code

**KBK/BKK - 60 - 105 - 16H7 - 14H7 - 20Nm - C or D - 1**

Type      Size      Length      ØD1 (H7)      ØD2 (H7)      Disengagement Torque      Torque Range  
 C = Single Position    D = Multi Position Engagement

Size	Dimensions (mm)									Technical Data										
	ØD	L	ØD1	ØD2	ØD3	H	F	L1	S	max. speed (1/min)	Mass (kg)	Moment of Inertia J (kg cm²)	Torque Range		Spring Stiffness			Misalignment		
	Outer Ø	Length	Bore Size (H7) min-max	Bore Size (H7) min-max	Hub Ø	Screw ISO4762 TA (Nm)			1 TKN (Nm)				2 TKN (Nm)	torsional x10³ CT (Nm/rad)	radial CR (N/mm)	axial CA (N/mm)	radial Δ Kr (mm)	axial Δ Ka (mm)	angular Δ Kw (°)	
-2	29	46 52 56	3-14	3-8	25	9	M3	21 27 31	0.7	13200	0.08	0.06	0.2 - 1.5	0.5 - 2	1.5 1.3 1.0	67 21 11	12 11 9	0.15 0.20 0.25	0.3 0.4 0.5	1.5 1.5 2
-4.5	36	57 65	6-16	6-13 9#	32.5	12	M4	27 3.5 36	0.7	12300	0.16	0.26	1 - 3	3 - 6	6.5 4.2	168 41	32 20	0.1 0.2	0.3 0.5	1.5 2
-7	49	65 75	6-25	6-16 11#	40	15.5	M4	34 5.1 43	0.7	11690	0.25	0.58	1 - 4	3 - 7	8.1 6.8	120 29	27 17	0.15 0.3	0.4 0.6	1.5 2
-10	49	65 75	6-25	6-16 11#	40	15.5	M4	34 5.1 43	0.7	11690	0.25	0.6	3 - 7	5 - 10	8.1 6.8	120 29	27 17	0.15 0.3	0.4 0.6	1.5 2
-30	64	85 94	10-32 30#	10-20 14#	56	20	M6	40.5 15 48.5	1.2	9540	0.77	3.2	5 - 15	10 - 30	38 28	720 225	50 28	0.15 0.25	0.6 1	1.5 2
-60	79	105 115	12-32	12-28 21#	66	23	M8	50 36 60	1.2	8180	1.34	8.2	12 - 35	20 - 60	75 50	1150 340	90 50	0.15 0.25	0.6 1	1.5 2
-80	94	113 125	14-42	14-35 27#	82	28	M10	57.5 72 68.5	2	6220	3.52	31	15 - 40	30 - 80	128 75	1200 400	80 50	0.2 0.25	0.5 0.8	1.5 2
-150	94	113 125	19-42	14-35 27#	82	28	M10	57.5 72 68.5	2	6220	3.52	31	50 - 130	65 - 150	155 105	2020 595	145 85	0.2 0.25	0.5 0.8	1.5 2
-200	109	125 138	22-45	22-41 33#	90	31	M12	63 125 75	2	5720	4.45	53	30 - 90	80 - 200	175 116	2500 460	147 82	0.2 0.25	0.5 0.8	1.5 2
-300	119	140 150	30-60	30-50 41#	110	39	M12	67 125 78	2	5200	6.47	97	60 - 200	150 - 300	502 285	6300 1400	280 145	0.2 0.25	0.5 0.8	1.5 2
-500	129	158 170	35-70	35-56 46#	122	42	M12	70 125 81	2	4470	9.22	164	80 - 250	200 - 500	690 320	7790 970	100 85	0.2 0.25	0.5 1	1.5 2

<b>Bore</b>	> Ø D2 and ≤ D2* only over LD
<b>Material</b>	bellows – stainless steel collet clamp (size 2 to size 60): aluminium collet clamp (size 80 to size 500): steel
<b>Keyway</b>	optional acc. DIN 6885 biggest bore marked with a #
<b>Temperature Range</b>	-30 °C ~ 120 °C

Size	2	45	7	10	30	60	80	150	200	300	500
D2*	11	X	20	20	26	31	38	38	X	57	62
LD	15	X	20	20	28	38	34	34	X	42	56

### Safety Coupling

with collet clamp and inner cone

optional  
nickel-plated version  
optional full stainless  
steel version

optional  
laserwelded

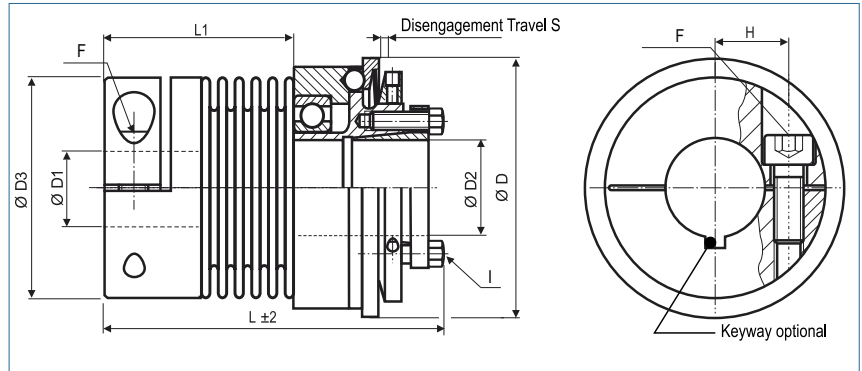

Order Code

**KBK/BKI - 60 - 100 - 16H7 - 14H7 - 20Nm - C or D - 1**

Type      Size      Length      ØD1 (H7)      ØD2 (H7)      Disengagement Torque      Torque Range  
 C = Single Position    D = Multi Position Engagement

Size	Dimensions (mm)										Technical Data										
	ØD	L	Ø D1	Ø D2	Ø D3	H	F	L1	I	S	max. speed (1/min)	Mass (kg)	Moment of Inertia J (kg cm²)	Torque Range		Spring Stiffness			Misalignment		
	Outer Ø	Length	Bore Size (H7) min-max	Bore Size (H7) min-max	Hub Ø	Screw ISO4762 TA (Nm)	Screw ISO4017 TA (Nm)	1 TKN (Nm)	2 TKN (Nm)	torsional x10³ CT (Nm/rad)				radial CR (N/mm)	axial CA (N/mm)	radial Δ Kr (mm)	axial Δ Ka (mm)	angular Δ Kw (°)			
-10	49	65 75	6-25	6-14 10#	40	15.5	M4 5.1	34 43	M3 2.1	0.7	11690	0.24	0.6	3-7 5-10	8.1 6.8	120 29	27 17	0.15 0.3	0.4 0.6	1.5 2	
-30	64	77.5 86.5	10-32 30#	12-20 14#	56	20	M6 15	40.5 48.5	M5 6	1.2	9540	0.72	3.0	5-15 10-30	38 28	720 225	50 28	0.15 0.25	0.6 1	1.5 2	
-60	79	90 100	12-32	15-25 18#	66	23	M8 36	50 60	M6 8.5	1.2	8180	1.3	7.9	12-35 20-60	75 50	1150 340	90 50	0.15 0.25	0.6 1	1.5 2	
-80	94	106 118	14-42	20-35 27#	82	28	M10 72	57.5 68.5	M6 14	2	6220	2.84	25	15-40 30-80	128 75	1200 400	80 50	0.2 0.25	0.5 0.8	1.5 2	
-150	94	106 118	19-42	20-35 27#	82	28	M10 72	57.5 68.5	M6 14	2	6220	2.84	25	50-130 65-150	155 105	2020 595	145 85	0.2 0.25	0.5 0.8	1.5 2	
-200	109	113 126	22-45	20-40 32#	90	31	M12 125	63 75	M6 14	2	5720	3.48	41	30-90 80-200	175 116	2500 460	147 82	0.2 0.25	0.5 0.8	1.5 2	
-300	119	131 141	30-60	25-45 37#	110	39	M12 125	67 78	M8 18	2	5200	5.35	80	60-200 150-300	502 285	6300 1400	280 145	0.2 0.25	0.5 0.8	1.5 2	
-500	129	140 151	35-70	35-55 45#	122	42	M12 125	70 81	M8 26	2	4470	7.54	134	80-250 200-500	690 320	7790 970	100 85	0.2 0.25	0.5 1	1.5 2	

**Material**      bellows – stainless steel  
 collet clamp (size 2 to size 60): aluminium  
 collet clamp (size 80 to size 500): steel  
 inner cone: steel

**Keyway**      optional acc. DIN 6885  
 biggest bore marked with a #

**Temperature Range**    -30 °C ~ 120 °C

Safety Coupling

with collet clamp and outer cone

optional  
nickel-plated version  
optional full stainless  
steel version

optional  
laserwelded

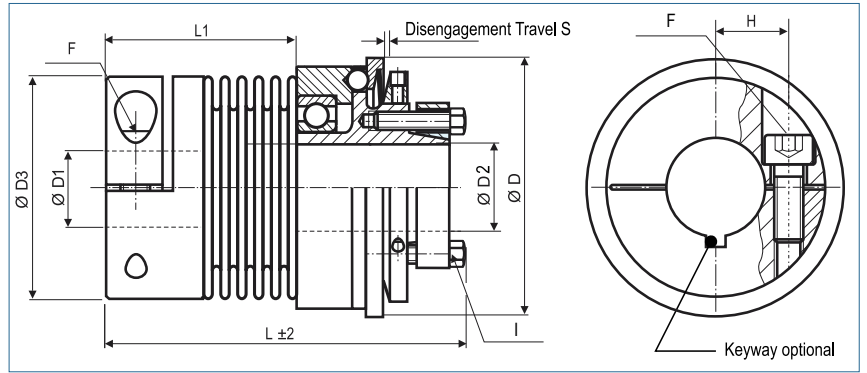

Order Code

**KBK/BKA - 60 - 108 - 16H7 - 14H7 - 20Nm - C or D - 1**

Type      Size      Length      ØD1 (H7)      ØD2 (H7)      Disengagement Torque      Torque Range  
 C = Single Position    D = Multi Position Engagement

Size	Dimensions (mm)										Technical Data										
	ØD	L	Ø D1	Ø D2	Ø D3	H	F	L1	I	S	max. speed (1/min)	Mass (kg)	Moment of Inertia (kg cm <sup>2</sup> )	Torque Range		Spring Stiffness			Misalignment		
	Outer Ø	Length	Bore Size (H7) min-max	Bore Size (H7) min-max	Hub Ø	Screw ISO4762 TA (Nm)	Screw ISO4017 TA (Nm)	1 TKN (Nm)	2 TKN (Nm)	torsional x10 <sup>3</sup> CT (Nm/rad)				radial CR (N/mm)	axial CA (N/mm)	radial Δ Kr (mm)	axial Δ Ka (mm)	angular Δ Kw (°)			
-10	49	67	6-25	5-14	40	15.5	M4	34	M3	0.7	11690	0.24	0.6	3 - 7	5 - 10	8.1	120	27	0.15	0.4	1.5
		77		10#			5.1	43	2.1					6.8	29	17	0.3	0.6	2		
-30	64	81	10-32	12-20	56	20	M6	40.5	M5	1.2	9540	0.71	2.9	5 - 15	10 - 30	38	720	50	0.15	0.6	1.5
		90	30#	14#			15	48.5	5.9					28	225	28	0.25	1	2		
-60	79	98	12-32	15-25	66	23	M8	50	M5	1.2	8180	1.29	7.9	12 - 35	20 - 60	75	1150	90	0.15	0.6	1.5
		108	18#	36			60	8.7	50					340	50	0.25	1	2			
-80	94	115	14-42	20-35	82	28	M10	57.5	M6	2	6220	2.89	25	15 - 40	30 - 80	128	1200	80	0.2	0.5	1.5
		127		27#			72	68.5	15					75	400	50	0.25	0.8	2		
-150	94	115	19-42	20-35	82	28	M10	57.5	M6	2	6220	2.89	25	50 - 130	65 - 150	155	2020	145	0.2	0.5	1.5
		126		27#			72	68.5	15					105	595	85	0.25	0.8	2		
-200	109	122	22-45	20-42	90	31	M12	63	M6	2	5720	3.5	42	30 - 90	80 - 200	175	2500	147	0.2	0.5	1.5
		135		34#			125	75	15					116	460	82	0.25	0.8	2		
-300	119	140	30-60	25-50	110	39	M12	67	M8	2	5200	5.23	79	60 - 200	150 - 300	502	6300	280	0.2	0.5	1.5
		150		41#			125	78	25					285	1400	145	0.25	0.8	2		
-500	129	154	34-70	35-55	122	42	M12	70	M8	2	4470	7.5	135	80 - 250	200 - 500	690	7790	100	0.2	0.5	1.5
		165		45#			125	81	36					320	970	85	0.25	1	2		

**Material**      outer cone – steel  
 bellows - stainless steel  
 collet clamp - aluminium;  
 from Size 80 - steel

**Keyway**      optional acc. DIN 6885  
 biggest bore marked with a #

**Temperature Range**    -30 °C ~ 120 °C



# Safety Coupling

with split hubs

optional  
nickel-plated version  
optional full stainless  
steel version

optional  
laserwelded

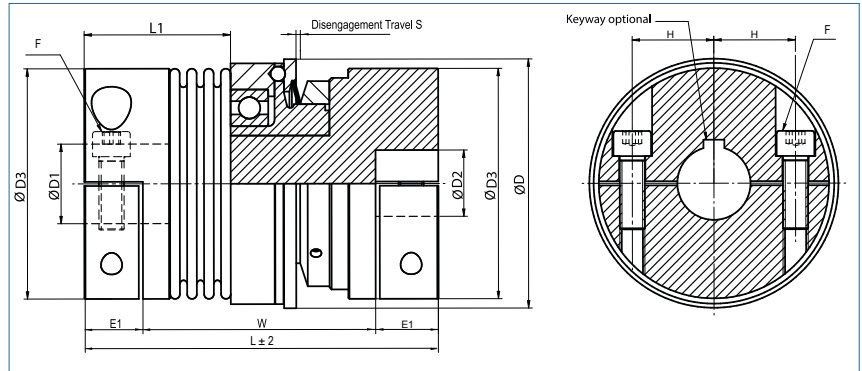

## Order Code

**KBK/BHH - 60 - 114 - 16H7 - 14H7 - 20Nm - C or D - 1**

Type      Size      Length      ØD1 (H7)      ØD2 (H7)      Disengagement Torque      Torque Range  
 C = Single Position    D = Multi Position Engagement

Size	Dimensions (mm)											Technical Data										
	ØD	L	Ø D1	Ø D2	Ø D3	E1	H	F	L1	W	S	max. speed (1/min)	Mass (kg)	Moment of Inertia J (kg cm <sup>2</sup> )	Torque Range		Spring Stiffness			Misalignment		
	Outer Ø	Length	Bore Size (H7) min-max	Bore Size (H7) min-max	Hub Ø		Screw ISO4762 TA (Nm)								1 TKN (Nm)	2 TKN (Nm)	torsional x10 <sup>3</sup> CT (Nm/rad)	radial CR (N/mm)	axial CA (N/mm)	radial Δ Kr (mm)	axial Δ Ka (mm)	angular Δ Kw (°)
-10	49	72	6-25	6-25	40	9	15.5	M4	34	54	0.7	11690	0,429	1,198	3	5	8.1	120	27	0.15	0.4	1.5
		5.1						43	63	7					10	6.8	29	17	0.3	0.6	2	
-30	64	99	10-32	10-20	56	17	20	M6	42	65	1.2	9540	0,891	3,957	5	10	38	720	50	0.15	0.6	1.5
		15	51					73	15	30					28	225	28	0.25	1	2		
-60	79	116	12-32	12-28	66	22	23	M8	50	72	1.2	8180	1,523	9,705	12	20	75	1150	90	0.15	0.6	1.5
		36	60					83	35	60					50	340	50	0.25	1	2		
-80	94	136	14-42	14-35	82	24	28	M10	60	86	2	6220	2,967	26,428	15	30	128	1200	80	0.2	0.5	1.5
		72	72					98	40	80					75	400	50	0.25	0.8	2		
-150	94	136	19-42	14-35	82	24	28	M10	60	86	2	6220	2,967	26,428	50	65	155	2020	145	0.2	0.5	1.5
		72						72	98	130					150	105	595	85	0.25	0.8	2	
-200	109	146	22-45	22-41	90	24	31	M12	66	92	2	5720	3,611	45,831	30	80	175	2500	147	0.2	0.5	1.5
		125						78	105	90					200	116	460	82	0.25	0.8	2	
-300	119	171	30-60	30-50	110	30	39	M12	72	112	2	5200	5,561	92,694	60	150	502	6300	280	0.2	0.5	1.5
		145						83	122	200					300	285	1400	145	0.25	0.8	2	
-500	129	189	35-65	35-65	122	35	42	M12	81	118	2	4470	9,307	194,726	80	200	690	7790	100	0.2	0.5	1.5
		145						92	130	250					500	320	970	85	0.25	1	2	

<b>Material</b>	bellows – stainless steel hub - aluminium
<b>Keyway</b>	optional acc. DIN 6885 biggest bore marked with a #
<b>Temperature Range</b>	-30 °C ~ 120 °C

## Safety Coupling

axial pluggable, with collet clamp

optional  
nickel-plated version  
optional full stainless  
steel version

optional  
laserwelded

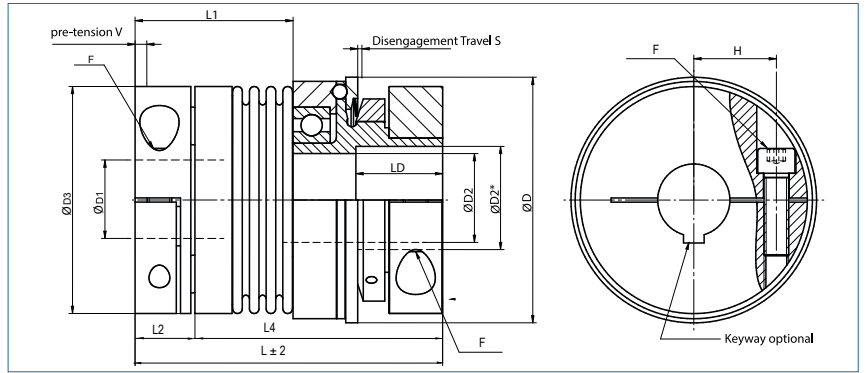

Order Code

**KBK/BKPK-60 - 121 - 16H7 - 14H7 - 20Nm - C or D - 1**

Type      Size      Length      ØD1 (H7)      ØD2 (H7)      Disengagement Torque      Torque Range

C = Single Position    D = Multi Position Engagement

Size	Dimensions (mm)									Technical Data										
	ØD	L	Ø D1	Ø D2	Ø D3	H	F	L1	S	max. speed (1/min)	Mass (kg)	Moment of Inertia J (kg cm <sup>2</sup> )	Torque Range		Spring Stiffness			Misalignment		
	Outer Ø	Length	Bore Size (H7) min~max	Bore Size (H7) min~max	Hub Ø	Screw ISO4762 TA (Nm)			1 TKN (Nm)				2 TKN (Nm)	torsional x10 <sup>3</sup> CT (Nm/rad)	radial CR (N/mm)	axial CA (N/mm)	radial Δ Kr (mm)	axial Δ Ka (mm)	angular Δ Kw (°)	
-2	29	52	3-14	3-8	25	9	M3	27	0.7	13200	0,07	0,068	0.2 - 1.5	0.5 - 2	1.5	67	12	0.15	0.3	1.5
		58	10#				1.3	21							11	0.20	0.4	1.5		
		62		2			37	1.0							11	9	0.25	0.5	2	
-4.5	36	64	6-16	6-13	32.5	12	M4	34	0.7	12300	0,15	0,22	1 - 3	3 - 6	6.5	168	32	0.1	0.3	1.5
		72	11#	9#			3.5	43							4.2	41	20	0.2	0.5	2
-7	49	73	6-25	6-16	40	15.5	M4	42	0.7	11690	0,31	0,866	1 - 4	3 - 7	8.1	120	27	0.15	0.4	1.5
		83	18#	11#			5.1	51							6.8	29	17	0.3	0.6	2
-10	49	73	6-25	6-16	40	15.5	M4	42	0.7	11690	0,31	0,866	3 - 5	5 - 10	8.1	120	27	0.15	0.4	1.5
		83	18#	11#			5.1	51							6.8	29	17	0.3	0.6	2
-30	64	91	10-30	10-20	56	20	M6	47	1.2	9540	0,75	3,59	5 - 15	10 - 30	38	720	50	0.15	0.6	1.5
		100	22#	14#			15	55							28	225	28	0.25	1	2
-60	79	111	12-35	12-28	66	23	M8	56	1.2	8180	1,21	8,65	12 - 35	20 - 60	75	1150	90	0.15	0.6	1.5
		121	27#	21#			40	66							50	340	50	0.25	1	2

<b>Bore</b>	> Ø D2 and ≤ D2* only over LD
<b>Material</b>	bellows – stainless steel collet clamp - aluminium plug hub- aluminium
<b>Keyway</b>	optional acc. DIN 6885 biggest bore marked with a #
<b>Temperature Range</b>	-30 °C ~ 120 °C

	Dimensions (mm)			
	E1	L2	L3	V
KBK/BKPK 2	10	11	16	0,5
KBK/BKPK 4,5	12	13	20	0,5
KBK/BKPK 7	12	13	21	0.5-1,0
KBK/BKPK 10	12	13	21	0.5-1.0
KBK/BKPK 30	17	19	31	0.5-1.0
KBK/BKPK 60	21	23	35	0.5-1.5

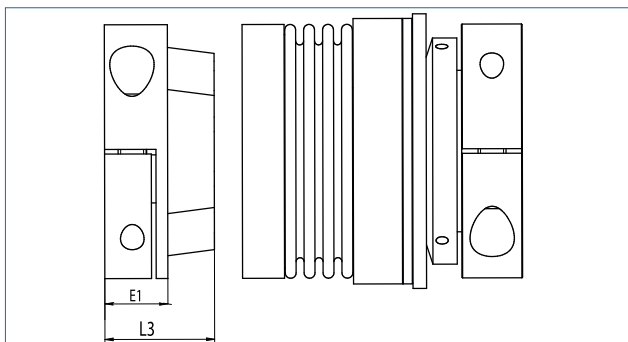

Size	2	4.5	7	10	30	60
D2*	11	X	20	20	26	31
LD	15	X	20	20	28	38

### Safety Coupling

axial pluggable, with collet clamp

optional  
nickel-plated version  
optional full stainless  
steel version

optional  
laserwelded

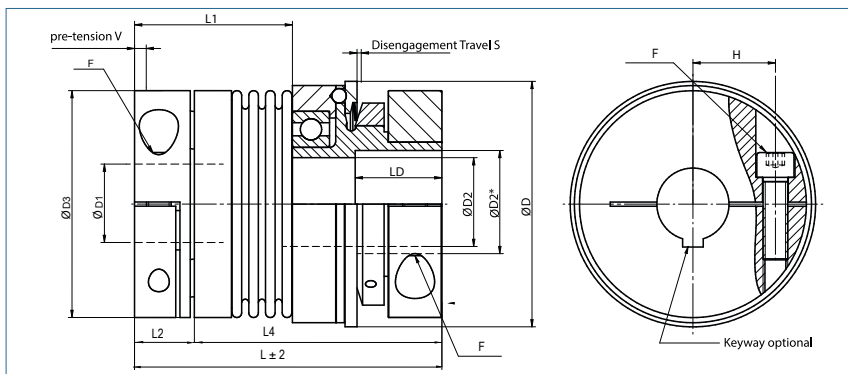

**Order Code**      **KBK/BKPK-80 - 117 - 12H7 - 20H7 - 25Nm - C or D - 1**

Type                      Size                      Length                      ØD1 (H7)                      ØD2 (H7)                      Disengagement Torque                      Torque Range  
C = Single Position    D = Multi Position Engagement

Size	Dimensions (mm)									Technical Data										
	ØD	L	Ø D1	Ø D2	Ø D3	H	F	L1	S	max. speed (1/min)	Mass (kg)	Moment of Inertia J (kg cm <sup>2</sup> )	Torque Range		Spring Stiffness			Misalignment		
	Outer Ø	Length	Bore Size (H7) min-max	Bore Size (H7) min-max	Hub Ø	Screw ISO4762 TA (Nm)			1 TKN (Nm)				2 TKN (Nm)	torsional x10 <sup>3</sup> CT (Nm/rad)	radial CR (N/mm)	axial CA (N/mm)	radial Δ Kr (mm)	axial Δ Ka (mm)	angular Δ Kw (°)	
-80	94	117	12-44	14-35	82	28	M10	61,5	2	6220	2,44	26,5	15 - 40	30 - 80	128	1200	80	0.2	0.5	1.5
		129	36#	27#			72	72,5					75	400	50	0.25	0.8	2		
-150	94	117	14-44	14-35	82	28	M10	61,5	2	6220	2,44	26,5	50 - 130	65 - 150	155	2020	145	0.2	0.5	1.5
		129	36#	27#			84	72,5					105	595	85	0.25	0.8	2		
-200	109	129	16-48	22-41	90	31	M12	67	2	5720	3,44	48,6	30 - 90	80 - 200	175	2500	147	0.2	0.5	1.5
		142	39#	33#			125	79					116	460	82	0.25	0.8	2		
-300	119	149	20-60	30-50	110	39	M12	76	2	5200	4,79	91,6	60 - 200	150 - 300	502	6300	280	0.2	0.5	1.5
		159	50#	41#			145	87					285	1400	145	0.25	0.8	2		
-500	129	182	25-70	35-56	122	42	M12	94	2	4470	7,65	178,8	80 - 250	200 - 500	690	7790	100	0.2	0.5	1.5
		194	58#	46#			145	105					320	970	85	0.25	1	2		

**Bore** > Ø D2 and ≤ D2\* only over LD

**Material** bellows – stainless steel  
collet clamp - aluminium  
plug hub- aluminium

**Keyway** optional acc. DIN 6885  
biggest bore marked with a #

**Temperature Range** -30 °C ~ 120 °C

	Dimensions (mm)			
	E1	L2	L3	V
KBK/KBPK 80	21,5	23.5	37.5	0.5-1.5
KBK/KBPK 150	21,5	23.5	37.5	0.5-1.5
KBK/KBPK 200	24	26	42	0.5-1.5
KBK/KBPK 300	27	29	47	0.5-1.5
KBK/KBPK 500	42	44	66	0.5-2.0

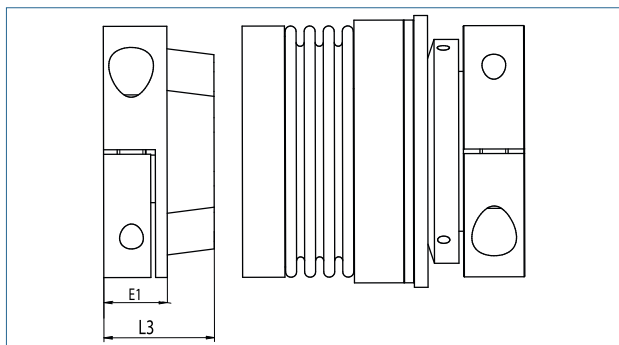

Size	80	150	200	300	500
D2*	38	38	X	57	62
LD	34	34	X	42	56

Safety Coupling

axial pluggable, with inner cone

optional  
nickel-plated version  
optional full stainless  
steel version

optional  
laserwelded

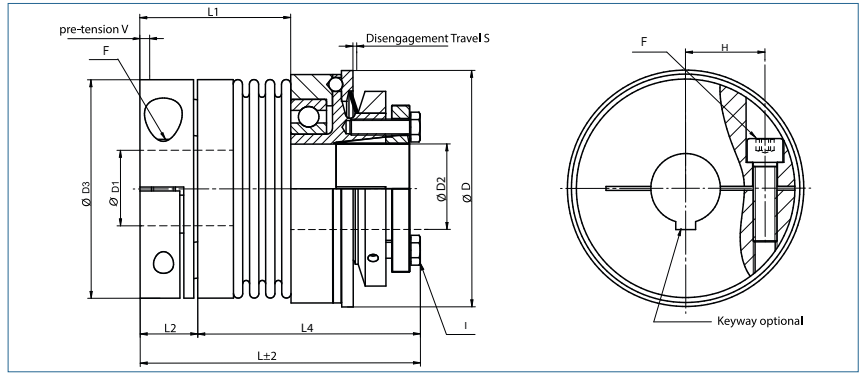

Order Code

**KBK/BKPI-60 - 105 - 16H7 - 14H7 - 20Nm - C or D - 1**

Type      Size      Length      ØD1 (H7)      ØD2 (H7)      Disengagement Torque      Torque Range

C = Single Position    D = Multi Position Engagement

Size	Dimensions (mm)										Technical Data										
	ØD	L	Ø D1	Ø D2	Ø D3	H	F	L1	I	S	max. speed (1/min)	Mass (kg)	Moment of Inertia J (kg cm²)	Torque Range		Spring Stiffness			Misalignment		
	Outer Ø	Length	Bore Size (H7) min-max	Bore Size (H7) min-max	Hub Ø	Screw ISO4762 TA (Nm)	Screw ISO4017 TA (Nm)	1 TKN (Nm)	2 TKN (Nm)	torsional x10³ CT (Nm/rad)				radial CR (N/mm)	axial CA (N/mm)	radial Δ Kr (mm)	axial Δ Ka (mm)	angular Δ Kw (°)			
-10	49	73	6-25	6-14	40	15.5	M4	42	M3	0.7	11690	0,30	0,83	3 - 7	5 - 10	8.1	120	27	0.15	0.4	1.5
		83	18#	10#			6.8	29	17					0.3	0.6	2					
-30	64	84	10-30	12-20	56	20	M6	47	M5	1.2	9540	0,67	3,21	5 - 15	10 - 30	38	720	50	0.15	0.6	1.5
		93	22#	14#			28	225	28					0.25	1	2					
-60	79	96	12-35	15-25	66	23	M8	56	M6	1.2	8180	1,15	7,90	12 - 35	20 - 60	75	1150	90	0.15	0.6	1.5
		106	27#	18#			50	340	50					0.25	1	2					
-80	94	110	14-44	20-35	82	28	M10	62	M6	2	6220	1,89	20,61	15 - 40	30 - 80	128	1200	80	0.2	0.5	1.5
		122	36#	27#			75	400	50					0.25	0.8	2					
-150	94	110	19-44	20-35	82	28	M10	62	M6	2	6220	1,89	20,61	50 - 130	65 - 150	155	2020	145	0.2	0.5	1.5
		122	36#	27#			105	595	85					0.25	0.8	2					
-200	109	117	22-48	20-40	90	31	M12	67	M6	2	5720	2,54	26,63	30 - 90	80 - 200	175	2500	147	0.2	0.5	1.5
		126	39#	32#			116	460	82					0.25	0.8	2					
-300	119	140	20-60	25-45	110	39	M12	76	M8	2	5200	3,84	69,77	60 - 200	150 - 300	502	6300	280	0.2	0.5	1.5
		150	50#	37#			285	1400	145					0.25	0.8	2					
-500	129	164	25-70	35-55	122	42	M12	94	M8	2	4470	5,13	118,22	80 - 250	200 - 500	690	7790	100	0.2	0.5	1.5
		175	58#	45#			320	970	85					0.25	1	2					

**Material** bellows – stainless steel  
inner cone - steel  
plug hub- aluminium

**Keyway** optional acc. DIN 6885  
biggest bore marked with a #

**Temperature Range** -30 °C ~ 120 °C

	Dimensions (mm)			
	E1	L2	L3	V
KBK/BKPI 10	12	13	21	0.5-1.0
KBK/BKPI 30	17	19	31	0.5-1.0
KBK/BKPI 60	21	23	35	0.5-1.5
KBK/BKPI 80	21.5	23.5	37.5	0.5-1.5
KBK/BKPI 150	21.5	23.5	37.5	0.5-1.5
KBK/BKPI 200	24	26	42	0.5-1.5
KBK/BKPI 300	27	29	47	0.5-1.5
KBK/BKPI 500	42	44	66	0.5-2.0

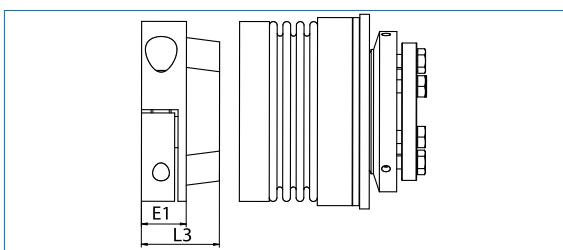

## Safety Coupling

axial pluggable, with outer cone

optional  
nickel-plated version  
optional full stainless  
steel version

optional  
laserwelded

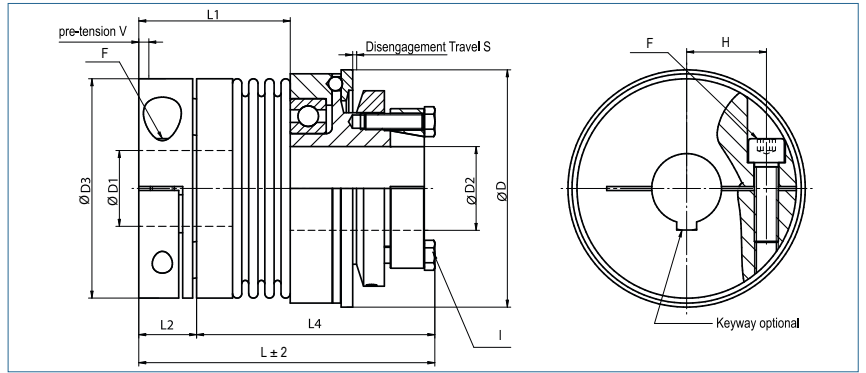

Order Code

**KBK/BKPA-60 - 104 - 20H7 - 25H7 - 20Nm - C or D - 1**

Type      Size      Length      ØD1 (H7)      ØD2 (H7)      Disengagement Torque      Torque Range

C = Single Position    D = Multi Position Engagement

Size	Dimensions (mm)										Technical Data										
	ØD	L	Ø D1	Ø D2	Ø D3	H	F	L1	I	S	max. speed (1/min)	Mass (kg)	Moment of Inertia J (kg cm²)	Torque Range		Spring Stiffness			Misalignment		
	Outer Ø	Length	Bore Size (H7) min-max	Bore Size (H7) min-max	Narben-durchmesser	Screw ISO4762 TA (Nm)	Screw ISO4017 TA (Nm)	1 TKN (Nm)	2 TKN (Nm)	torsional x10° CT (Nm/rad)				radial CR (N/mm)	axial CA (N/mm)	radial Δ Kr (mm)	axial Δ Ka (mm)	angular Δ Kw (°)			
-10	49	75 85	6-25 18#	5-12 8#	40	15.5	M4 5.1	42 51	M3 2.1	0.7	11690	0,32	0,85	3 - 7 5 - 10	8.1 6.8	120 29	27 17	0.15 0.3	0.4 0.6	1.5 2	
-30	64	88 97	10-30 22#	12-20 14#	56	20	M6 15	47 55	M5 5.9	1.2	9540	0,72	3,38	5 - 15 10 - 30	38 28	720 225	50 28	0.15 0.25	0.6 1	1.5 2	
-60	79	104 114	12-35 27#	15-25 18#	66	23	M8 40	56 66	M5 8.7	1.2	8180	1,22	8,79	12 - 35 20 - 60	75 50	1150 340	90 50	0.15 0.25	0.6 1	1.5 2	
-80	94	119 130	14-44 36#	20-35 27#	82	28	M10 72	62 73	M6 15	2	6220	2,11	22,71	15 - 40 30 - 80	128 75	1200 400	80 50	0.2 0.25	0.5 0.8	1.5 2	
-150	94	119 130	19-44 36#	20-35 27#	82	28	M10 84	62 73	M6 15	2	6220	2,11	22,71	50 - 130 65 - 150	155 105	2020 595	145 85	0.2 0.25	0.5 0.8	1.5 2	
-200	109	126 139	22-48 39#	20-42 34#	90	31	M12 125	67 79	M6 15	2	5720	2,8	39,44	30 - 90 80 - 200	175 116	2500 460	147 82	0.2 0.25	0.5 0.8	1.5 2	
-300	119	149 159	20-60 50#	25-50 41#	110	39	M12 145	76 87	M8 25	2	5200	3,8	70,27	60 - 200 150 - 300	502 285	6300 1400	280 145	0.2 0.25	0.5 0.8	1.5 2	
-500	129	178 189	25-70 58#	35-55 45#	122	42	M12 145	94 105	M8 36	2	4470	5,85	130,63	80 - 250 200 - 500	690 320	7790 970	100 85	0.2 0.25	0.5 1	1.5 2	

<b>Material</b>	outer cone -steel bellows – stainless steel plug hub- aluminium
<b>Keyway</b>	optional acc. DIN 6885 biggest bore marked with a #
<b>Temperature Range</b>	-30 °C ~ 120 °C

	Dimensions (mm)			
	E1	L2	L3	V
KBK/KBPA 10	12	13	21	0.5-1.0
KBK/KBPA 30	17	19	31	0.5-1.0
KBK/KBPA 60	21	23	35	0.5-1.5
KBK/KBPA 80	21.5	23.5	37.5	0.5-1.5
KBK/KBPA 150	21.5	23.5	37.5	0.5-1.5
KBK/KBPA 200	24	26	42	0.5-1.5
KBK/KBPA 300	27	29	47	0.5-1.5
KBK/KBPA 500	42	44	66	0.5-2.0

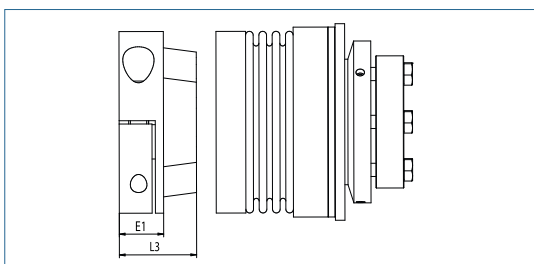

Safety Coupling

with inner cone and collet clamp

optional  
nickel-plated version  
optional full stainless  
steel version

optional  
laserwelded

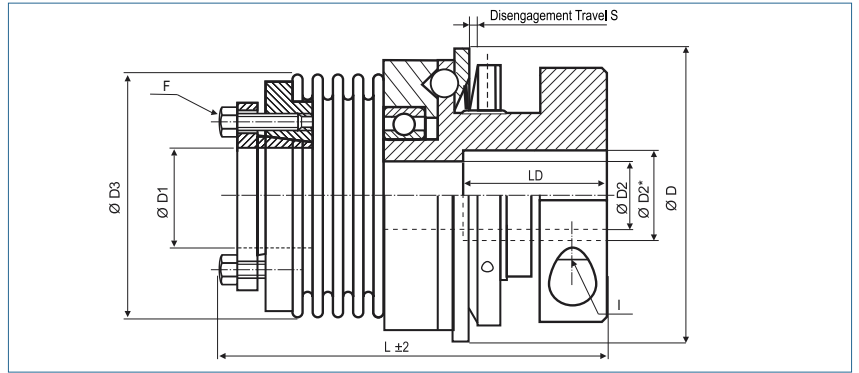

Order Code

**KBK/BIK - 60 - 107 - 15H7 - 18H7 - 20Nm - C or D - 2**

Type      Size      Length      ØD1 (H7)      ØD2 (H7)      Disengagement Torque      Torque Range  
 C = Single Position    D = Multi Position Engagement

Size	Dimensions (mm)								Technical Data										
	ØD	L	ØD1	ØD2	ØD3	F	I	S	max. speed (1/min)	Mass (kg)	Moment of Inertia J (kg cm²)	Torque Range		Spring Stiffness			Misalignment		
	Outer Ø	Length	Bore Size (H7) min-max	Bore Size (H7) min-max		Screw ISO4017 TA (Nm)	Screw ISO4762 TA (Nm)					1 TKN (Nm)	2 TKN (Nm)	torsional x10³ CT (Nm/rad)	radial CR (N/mm)	axial CA (N/mm)	radial Δ Kr (mm)	axial Δ Ka (mm)	angular Δ Kw (°)
-10	49	68	6-14	6-16	40.5	M3	M4	0.7	11650	0.27	0.6	3 - 7	5 - 10	8.1	120	27	0.15	0.4	1.5
		78	10#	11#		2.1	5.1					6.8	29	17	0.3	0.6	2		
-30	64	79	12-20	10-20	56	M5	M6	1.2	9540	0.81	3.3	5 - 15	10 - 30	38	720	50	0.15	0.6	1.5
		88	14#	14#		6	15					28	225	28	0.25	1	2		
-60	79	97	15-25	12-28	66	M6	M8	1.2	8180	1.48	9	12 - 35	20 - 60	75	1150	90	0.15	0.6	1.5
		107	18#	21#		8.5	36					50	340	50	0.25	1	2		
-80	94	107	20-35	14-35	82	M6	M10	2	6220	3.2	28	15 - 40	30 - 80	128	1200	80	0.2	0.5	1.5
		119	27#	27#		14	72					75	400	50	0.25	0.8	2		
-150	94	107	20-35	14-35	82	M6	M10	2	6220	3.2	28	50 - 130	65 - 150	155	2020	145	0.2	0.5	1.5
		119	27#	27#		14	72					105	595	85	0.25	0.8	2		
-200	109	114	20-40	22-41	90	M6	M12	2	5720	3.9	46	30 - 90	80 - 200	175	2500	147	0.2	0.5	1.5
		127	32#	33#		14	125					116	460	82	0.25	0.8	2		
-300	119	133	25-50	30-50	110	M8	M12	2	5200	6.1	92	60 - 200	150 - 300	502	6300	280	0.2	0.5	1.5
		143	41#	41#		18	125					285	1400	145	0.25	0.8	2		
-500	129	147	35-55	35-56	122	M8	M12	2	4470	8.4	150	80 - 250	200 - 500	690	7790	100	0.2	0.5	1.5
		158	45#	46#		26	125					320	970	85	0.25	1	2		

**+**

**Bores** > Ø D2 and ≤ D2\* only over LD

**Material** bellows – stainless steel  
inner cone - steel  
collet clamp - aluminium;  
from Size 80 - steel

**Keyway** optional acc. DIN 6885  
biggest bore marked with a #

**Temperature Range** -30 °C ~ 120 °C

Size	2	45	7	10	30	60	80	150	200	300	500
D2*	11	X	20	20	26	31	38	38	X	57	62
LD	15	X	20	20	28	38	34	34	X	42	56

## Safety Coupling

with two inner cones

optional  
nickel-plated version  
optional full stainless  
steel version

optional  
laserwelded

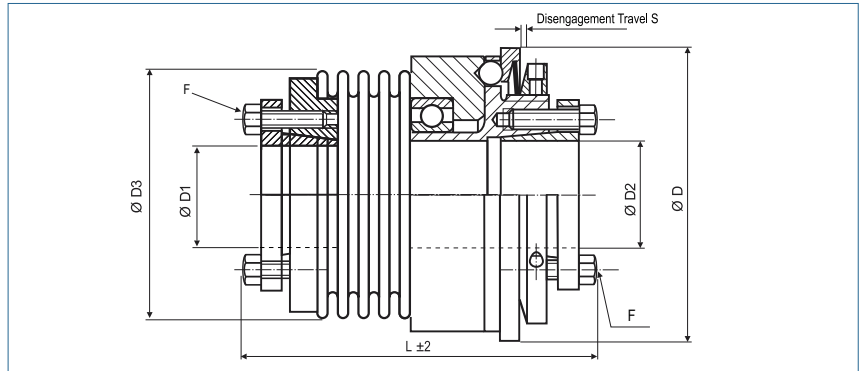

Order Code

**KBK/BII - 60 - 100 - 15H7 - 18H7 - 20Nm - C or D - 2**

Type      Size      Length      ØD1 (H7)      ØD2 (H7)      Disengagement Torque      Torque Range

C = Single Position    D = Multi Position Engagement

Size	Dimensions (mm)							Technical Data										
	ØD	L	ØD1	ØD2	ØD3	F	S	max. speed (1/min)	Mass (kg)	Moment of Inertia J (kg cm²)	Torque Range		Spring Stiffness			Misalignment		
	Outer Ø	Length	Bore Size (H7) min-max	Bore Size (H7) min-max	Screw ISO4017 TA (Nm)		1 TKN (Nm)				2 TKN (Nm)	torsional x10³ CT (Nm/rad)	radial CR (N/mm)	axial CA (N/mm)	radial Δ Kr (mm)	axial Δ Ka (mm)	angular Δ Kw (°)	
-10	49	68	6-14	6-14	40.5	M3	0.7	11650	0.27	0.6	3 - 7	5 - 10	8.1	120	27	0.15	0.4	1.5
		78	10#	10#		2.1							6.8	29	17	0.3	0.6	2
-30	64	85	12-20	12-20	56	M5	1.2	9540	0.76	3.1	5 - 15	10 - 30	38	720	50	0.15	0.6	1.5
		94	14#	14#		6							28	225	28	0.25	1	2
-60	79	100	15-25	15-25	66	M6	1.2	8180	1.44	8.8	12 - 35	20 - 60	75	1150	90	0.15	0.6	1.5
		110	18#	18#		8.5							50	340	50	0.25	1	2
-80	94	115	20-35	20-35	82	M6	2	6220	2.5	22	15 - 40	30 - 80	128	1200	80	0.2	0.5	1.5
		128	27#	27#		14							75	400	50	0.25	0.8	2
-150	94	115	20-35	20-35	82	M6	2	6220	2.5	22	50 - 130	65 - 150	155	2020	145	0.2	0.5	1.5
		128	27#	27#		14							105	595	85	0.25	0.8	2
-200	109	125	20-40	20-40	90	M6	2	5720	2.88	34	30 - 90	80 - 200	175	2500	147	0.2	0.5	1.5
		135	32#	32#		14							116	460	82	0.25	0.8	2
-300	119	135	25-50	25-45	110	M8	2	5200	5.0	75	60 - 200	150 - 300	502	6300	280	0.2	0.5	1.5
		145	41#	37#		18							285	1400	145	0.25	0.8	2
-500	129	150	35-55	35-55	122	M8	2	4470	6.73	120	80 - 250	200 - 500	690	7790	100	0.2	0.5	1.5
		162	45#	45#		26							320	970	85	0.25	1	2
-800	169	235	50-70	50-70	157	M16	2	3350	17.8	518	240 - 600	500 - 800	700	500	185	0.2	0.8	1.8
			58#	58#		45												
-1400	169	235	50-70	50-70	157	M16	2	3350	18.0	523	360 - 1000	900 - 1400	1270	700	275	0.2	0.8	1.8
			58#	58#		80												



<b>Material</b>	bellows – stainless steel inner cone - steel
<b>Keyway</b>	optional acc. DIN 6885 biggest bore marked with a #
<b>Temperature Range</b>	-30 °C ~ 120 °C

### Safety Coupling

with inner cone and outer cone

optional  
nickel-plated version  
optional full stainless  
steel version

optional  
laserwelded

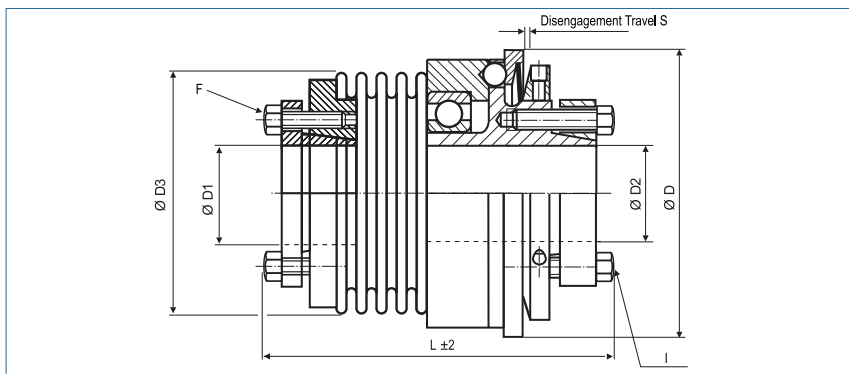

**Order Code**

**KBK/BIA - 60 - 100 - 15H7 - 18H7 - 20Nm - C or D - 2**

Type      Size      Length      ØD1 (H7)      ØD2 (H7)      Disengagement Torque      Torque Range  
 C = Single Position    D = Multi Position Engagement

Size	Dimensions (mm)								Technical Data										
	ØD	L	ØD1	ØD2	ØD3	F	S	I	max. speed (1/min)	Mass (kg)	Moment of Inertia J (kg cm <sup>2</sup> )	Torque Range		Spring Stiffness			Misalignment		
	Outer Ø	Length	Bore Size (H7) min-max	Bore Size (H7) min-max	Screw ISO4017 TA (Nm)	Screw ISO4017 TA (Nm)	1 TKN (Nm)	2 TKN (Nm)				torsional x10 <sup>3</sup> CT (Nm/rad)	radial CR (N/mm)	axial CA (N/mm)	radial Δ Kr (mm)	axial Δ Ka (mm)	angular Δ Kw (°)		
-10	49	69	6-14	5-14	40.5	M3	0.7	M3	11650	0.27	0.6	3 - 7	5 - 10	8.1	120	27	0.15	0.4	1.5
		79	10#	10#		2.1		2.1						6.8	29	17	0.3	0.6	2
-30	64	74	12-20	12-20	56	M5	1.2	M5	9540	0.75	3.1	5 - 15	10 - 30	38	720	50	0.15	0.6	1.5
		83	14#	14#		6		5.9						28	225	28	0.25	1	2
-60	79	89	15-25	15-25	66	M6	1.2	M5	8180	1.43	8.8	12 - 35	20 - 60	75	1150	90	0.15	0.6	1.5
		100	18#	18#		8.5		8.7						50	340	50	0.25	1	2
-80	94	108	20-35	20-35	82	M6	2	M6	6220	2.5	22	15 - 40	30 - 80	128	1200	80	0.2	0.5	1.5
		120	27#	27#		14		15						75	400	50	0.25	0.8	2
-150	94	108	20-35	20-35	82	M6	2	M6	6220	2.5	22	50 - 130	65 - 150	155	2020	145	0.2	0.5	1.5
		120	27#	27#		14		15						105	595	85	0.25	0.8	2
-200	109	110	20-40	20-42	90	M6	2	M6	5720	2.9	34	30 - 90	80 - 200	175	2500	147	0.2	0.5	1.5
		123	32#	34#		14		15						116	460	82	0.25	0.8	2
-300	119	132	25-50	25-50	110	M8	2	M8	5200	4.9	73	60 - 200	150 - 300	502	6300	280	0.2	0.5	1.5
		143	41#	41#		18		25						285	1400	145	0.25	0.8	2
-500	129	149	35-55	35-55	122	M8	2	M8	4470	6.8	120	80 - 250	200 - 500	690	7790	100	0.2	0.5	1.5
		160	45#	45#		26		36						320	970	85	0.25	1	2
-800	169	243	50-70	50-70	157	M16	2	M12	3350	18	516	240 - 600	500 - 800	700	500	185	0.2	0.8	1.8
			58#	58#		45		85											
-1400	169	243	50-70	50-70	157	M16	2	M12	3350	18	520	360 - 1000	900 - 1400	1270	700	275	0.2	0.8	1.8
			58#	58#		80		115											

**+** **Material**      outer cone - steel  
 bellows – stainless steel  
 inner cone - steel

**Keyway**      optional acc. DIN 6885  
 biggest bore marked with a #

**Temperature Range**    -30 °C ~ 120 °C



Safety Coupling

with outer cone and collet clamp

optional  
nickel-plated version  
optional full stainless  
steel version

optional  
laserwelded

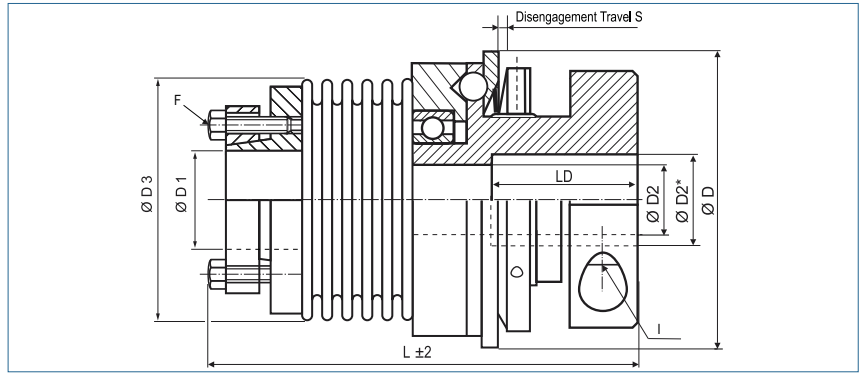

Order Code

**KBK/BAK - 60 - 115 - 15H7 - 18H7 - 20Nm - C or D - 2**

Type                      Size                      Length                      ØD1 (H7)                      ØD2 (H7)                      Disengagement Torque                      Torque Range

C = Single Position    D = Multi Position Engagement

Size	Dimensions (mm)								Technical Data										
	ØD	L	ØD1	ØD2	ØD3	F	S	I	max. speed (1/min)	Mass (kg)	Moment of Inertia J (kg cm <sup>2</sup> )	Torque Range		Spring Stiffness			Misalignment		
	Outer Ø	Length	Bore Size (H7) min~max	Bore Size (H7) min~max		Screw ISO4017 TA (Nm)		Screw ISO4762 TA (Nm)				1 TKN (Nm)	2 TKN (Nm)	torsional x10 <sup>3</sup> CT (Nm/rad)	radial CR (N/mm)	axial CA (N/mm)	radial Δ Kr (mm)	axial Δ Ka (mm)	angular Δ Kw (°)
-10	49	65 74	5-14 10# 11#	6-16 11#	40.5	M3 2.1	0.7	M4 5.1	11650	0.27	0.6	3 - 7	5 - 10	8.1 6.8	120 29	27 17	0.15 0.3	0.4 0.6	1.5 2
-30	64	82 92	12-20 14# 14#	10-20 14#	56	M5 5.9	1.2	M6 15	9540	0.80	3.3	5 - 15	10 - 30	38 28	720 225	50 28	0.15 0.25	0.6 1	1.5 2
-60	79	104 115	15-32 24# 21#	12-28 21#	66	M5 8.7	1.2	M8 36	8180	1.46	8.9	12 - 35	20 - 60	75 50	1150 340	90 50	0.15 0.25	0.6 1	1.5 2
-80	94	115 127	20-35 37# 37#	14-35 37#	82	M6 15	2	M10 72	6220	3.3	29	15 - 40	30 - 80	128 75	1200 400	80 50	0.2 0.25	0.5 0.8	1.5 2
-150	94	115 127	20-35 37# 37#	14-35 37#	82	M6 15	2	M10 72	6220	3.3	29	50 - 130	65 - 150	155 105	2020 595	145 85	0.2 0.25	0.5 0.8	1.5 2
-200	109	122 135	20-42 34# 33#	22-41 33#	90	M6 15	2	M12 125	5720	3.9	46	30 - 90	80 - 200	175 116	2500 460	147 82	0.2 0.25	0.5 0.8	1.5 2
-300	119	141 152	25-50 41# 41#	30-50 41#	110	M8 25	2	M12 125	5200	5.9	88	60 - 200	150 - 300	502 285	6300 1400	280 145	0.2 0.25	0.5 0.8	1.5 2
-500	129	163 175	35-55 45# 46#	35-56 46#	122	M8 36	2	M12 125	4470	8.5	151	80 - 250	200 - 500	690 320	7790 970	100 85	0.2 0.25	0.5 1	1.5 2

<b>+</b> Bores	> Ø D2 and ≤ D2* only over LD
<b>Material</b>	outer cone - steel bellows – stainless steel collet clamp - aluminium; from size 80 steel
<b>Keyway</b>	optional acc. DIN 6885 biggest bore marked with a #
<b>Temperature Range</b>	-30 °C ~ 120 °C

Size	2	45	7	10	30	60	80	150	200	300	500
D2*	11	X	20	20	26	31	38	38	X	57	62
LD	15	X	20	20	28	38	34	34	X	42	56

Safety Coupling

with outer cone and inner cone

optional  
nickel-plated version  
optional full stainless  
steel version

optional  
laserwelded

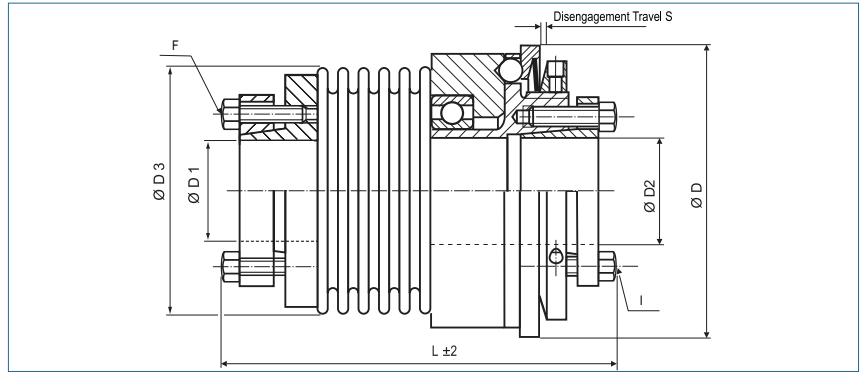

Order Code

**KBK/BAI - 60 - 100 - 15H7 - 18H7 - 20Nm - C or D - 2**

Type      Size      Length      ØD1 (H7)      ØD2 (H7)      Disengagement Torque      Torque Range  
 C = Single Position    D = Multi Position Engagement

Size	Dimensions (mm)								Technical Data										
	ØD	L	ØD1	ØD2	ØD3	F	S	I	max. speed (1/min)	Mass (kg)	Moment of Inertia J (kg cm <sup>2</sup> )	Torque Range		Spring Stiffness			Misalignment		
	Outer Ø	Length	Bore Size (H7) min~max	Bore Size (H7) min~max	Screw ISO4017 TA (Nm)	Screw ISO4017 TA (Nm)	1 TKN (Nm)	2 TKN (Nm)				torsional x10 <sup>3</sup> CT (Nm/rad)	radial CR (N/mm)	axial CA (N/mm)	radial Δ Kr (mm)	axial Δ Ka (mm)	angular Δ Kw (°)		
-10	49	65	5-14	6-14	40.5	M3	0.7	M3	11650	0.27	0.6	3 - 7	5 - 10	8.1	120	27	0.15	0.4	1.5
		74	10#	10#		2.1		2.1				6.8	29	17	0.3	0.6	2		
-30	64	75	12-20	12-20	56	M5	1.2	M5	9540	0.75	3.1	5 - 15	10 - 30	38	720	50	0.15	0.6	1.5
		84	14#	14#		5.9		6				28	225	28	0.25	1	2		
-60	79	89	15-32	15-25	66	M5	1.2	M6	8180	1.42	8.7	12 - 35	20 - 60	75	1150	90	0.15	0.6	1.5
		100	24#	18#		8.7		8.5				50	340	50	0.25	1	2		
-80	94	108	20-35	20-35	82	M6	2	M6	6220	2.6	23	15 - 40	30 - 80	128	1200	80	0.2	0.5	1.5
		120	27#	27#		15		14				75	400	50	0.25	0.8	2		
-150	94	108	20-35	20-35	82	M6	2	M6	6220	2.6	23	50 - 130	65 - 150	155	2020	145	0.2	0.5	1.5
		120	27#	27#		15		14				105	595	85	0.25	0.8	2		
-200	109	110	20-42	20-40	90	M6	2	M6	5720	2.9	34	30 - 90	80 - 200	175	2500	147	0.2	0.5	1.5
		123	34#	32#		15		14				116	460	82	0.25	0.8	2		
-300	119	133	25-50	25-45	110	M8	2	M8	5200	4.8	72	60 - 200	150 - 300	502	6300	280	0.2	0.5	1.5
		143	41#	37#		25		18				285	1400	145	0.25	0.8	2		
-500	129	145	35-55	35-55	122	M8	2	M8	4470	6.8	121	80 - 250	200 - 500	690	7790	100	0.2	0.5	1.5
		157	45#	45#		36		26				320	970	85	0.25	1	2		
-800	169	242	50-70	50-70	157	M12	2	M16	3350	17.8	515	240 - 600	500 - 800	700	500	185	0.2	0.8	1.8
			58#	58#		85		45											
-1400	169	242	50-70	50-70	157	M12	2	M16	3350	17.9	519	360 - 1000	900 - 1400	1270	700	275	0.2	0.8	1.8
			58#	58#		115		80											



<b>Material</b>	outer cone: steel bellows – stainless steel inner cone: steel
<b>Keyway</b>	optional acc. DIN 6885 biggest bore marked with a #
<b>Temperature Range</b>	-30 °C ~ 120 °C

### Safety Coupling

with two outer cones

optional  
nickel-plated version  
optional full stainless  
steel version

optional  
laserwelded

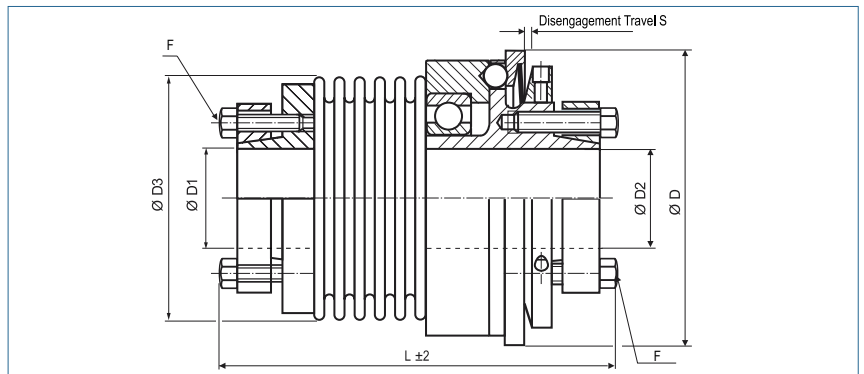

<b>Order Code</b>	<b>KBK/BAA - 60 - 108 - 15H7 - 18H7 - 20Nm - C or D - 2</b>						
	Type	Size	Length	ØD1 (H7)	ØD2 (H7)	Disengagement Torque	Torque Range
						C = Single Position D = Multi Position Engagement	

Size	Dimensions (mm)							Technical Data										
	ØD	L	ØD1	ØD2	ØD3	F	S	max. speed (1/min)	Mass (kg)	Moment of Inertia J (kg cm²)	Torque Range		Spring Stiffness			Misalignment		
	Outer Ø	Length	Bore Size (H7) min-max	Bore Size (H7) min-max		Screw ISO4017 TA (Nm)	1 TKN (Nm)				2 TKN (Nm)	torsional x10³ CT (Nm/rad)	radial CR (N/mm)	axial CA (N/mm)	radial Δ Kr (mm)	axial Δ Ka (mm)	angular Δ Kw (°)	
-10	49	66	5-14	5-14	40.5	M3	0.7	11650	0.27	0.6	3 - 5	7 - 10	8.1	120	27	0.15	0.4	1.5
		75	10#	10#		2.1					6.8	29	17	0.3	0.6	2		
-30	64	78	12-20	12-20	56	M5	1.2	9540	0.74	3.0	5 - 10	10 - 30	38	720	50	0.15	0.6	1.5
		87	14#	14#		5.9					30	28	225	28	0.25	1	2	
-60	79	97	15-32	15-25	66	M5	1.2	8180	1.41	8.6	12 - 15	20 - 30	75	1150	90	0.15	0.6	1.5
		108	24#	18#		8.7					35	60	50	340	50	0.25	1	2
-80	94	116	20-35	20-35	82	M6	2	6220	2.6	23	15 - 15	30 - 80	128	1200	80	0.2	0.5	1.5
		129	27#	27#		15					40	80	75	400	50	0.25	0.8	2
-150	94	116	20-35	20-35	82	M6	2	6220	2.6	23	50 - 130	65 - 150	155	2020	145	0.2	0.5	1.5
		129	27#	27#		15					130	150	105	595	85	0.25	0.8	2
-200	109	118	20-42	20-42	90	M6	2	5720	2.9	35	30 - 90	80 - 200	175	2500	147	0.2	0.5	1.5
		132	34#	34#		15					90	200	116	460	82	0.25	0.8	2
-300	119	141	25-50	25-50	110	M8	2	5200	4.6	70	60 - 200	150 - 300	502	6300	280	0.2	0.5	1.5
		152	41#	41#		25					200	300	285	1400	145	0.25	0.8	2
-500	129	159	35-55	35-55	122	M8	2	4470	6.8	121	80 - 250	200 - 500	690	7790	100	0.2	0.5	1.5
		171	45#	45#		36					250	500	320	970	85	0.25	1	2
-800	169	250	50-70	50-70	157	M12	2	3350	17.7	514	240 - 600	500 - 800	700	500	185	0.2	0.8	1.8
			58#	58#		85					600	800						
-1400	169	250	50-70	50-70	157	M12	2	3350	17.8	516	360 - 900	900 - 1400	1270	700	275	0.2	0.8	1.8
			58#	58#		115					1400							

<b>Material</b>	outer cone - steel bellows – stainless steel
<b>Keyway</b>	optional acc. DIN 6885 biggest bore marked with a #
<b>Temperature Range</b>	-30 °C ~ 120 °C

# Safety Couplings with elastomer inserts

## KBK|EPP -14 ~ 42

Safety Coupling  
with two keyways



P. 38

## KBK|EPK -14 ~ 42

Safety Coupling  
with keyway and collet clamp



P. 39

## KBK|EPI -14 ~ 42

Safety Coupling  
with keyway and inner cone



P. 40

## KBK|EPA -14 ~ 42

Safety Coupling  
with keyway and outer cone



P. 41

## KBK|EKP -14 ~ 42

Safety Coupling  
with collet clamp and keyway



P. 42

## KBK|EKK -14 ~ 42

Safety Coupling  
with two collet clamps



P. 43

## KBK|EKI -14 ~ 42

Safety Coupling  
with collet clamp and inner cone



P. 44

## KBK|EKA -14 ~ 42

Safety Coupling  
with collet clamp and outer cone



P. 45

## KBK|EHH -14 ~ 42

Safety Coupling  
with split hubs



P. 46

## KBK|EAP -14 ~ 42

Safety Coupling  
with outer cone and keyway



P. 47

## KBK|EAK -14 ~ 42

Safety Coupling  
with outer cone and collet clamp



P. 48

## KBK|EAI -14 ~ 42

Safety Coupling  
with outer cone and inner cone



P. 49

# Safety Couplings with elastomer inserts

**KBK|EAA -14 ~ 42**

Safety Coupling  
with two outer cones



P. 50

### Safety Coupling

with two keyways

optional  
nickel-plated version  
optional full stainless  
steel version

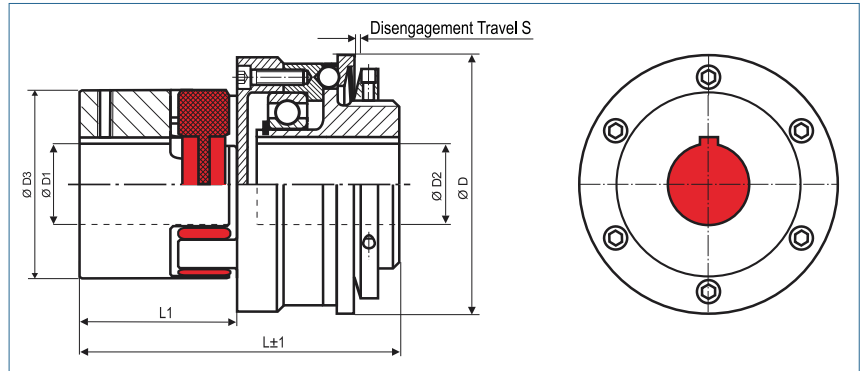

**Order Code**    **KBK/EPP - 24 - 98.5 - N16H7 - N15H7 - 20Nm - C or D - 2**

Type	Size	Length	ØD1 (H7)	ØD2 (H7)	Disengagement Torque	Torque Range
						C = Single Position    D = Multi Position Engagement

Size	Dimensions (mm)							Technical Data								
	ØD	L	Ø D1	Ø D2	Ø D3	L1	S	max. speed (1/min)	Mass (kg)	Moment of Inertia J (kg cm <sup>2</sup> )	Torque 98 Sh TKN (Nm)	Torque Range		Misalignment		
	Outer Ø	Length	Bore Size (H7) min~max	Bore Size (H7) min~max			1 TKN (Nm)					2 TKN (Nm)	radial Δ Kr (mm)	axial Δ Ka (mm)	angular Δ Kw (°)	
-14	49	55	6-16	6-12	30	24	0.7	11690	0.19	0.5	12.5	3-7	5-10	0.09	+1.0 -0.5	0.9
-19	64	81	10-24	10-16	40	41	1.2	8950	0.63	2.6	17	5-15	10-30	0.06	+1.2 -0.5	0.9
-24	79	98.5	16-28	15-24	55	50	1.2	7630	1.1	6.8	60	12-35	20-60	0.10	+1.4 -0.5	0.9
-28	94	121	20-38	19-29	65	59	2	6030	2	17	160	50-130	65-150	0.11	+1.5 -0.7	0.9
-38	119	134	20-45	20-42	80	67	2	4980	3.8	57	325	60-200	150-300	0.12	+1.8 -0.7	0.9
-42	129	157	20-55	20-50	95	76	2	4440	7.9	140	450	80-250	200-500	0.14	+2.0 -1.0	0.9

**+** **Material**                    hubs: aluminium  
   spider element: polyurethane 98 Sh A (red)

**Temperature Range**    -30 °C ~ 90 °C

### Safety Coupling

with keyway and collet clamp

optional  
nickel-plated version  
optional full stainless  
steel version

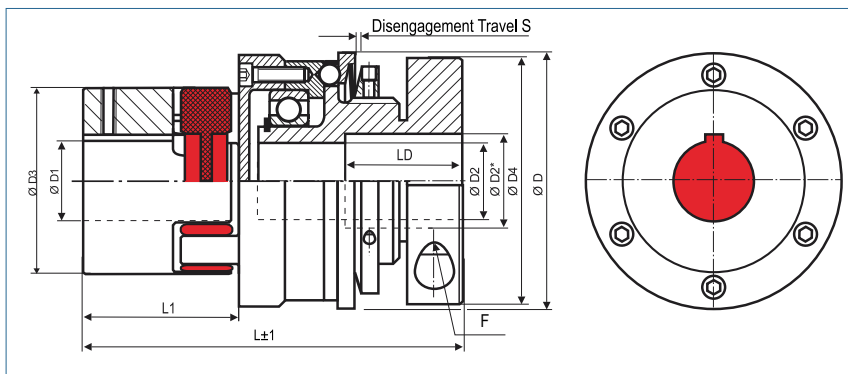

Order Code **KBK/EPK - 24 - 126.5 - N16H7 - 14H7 - 20Nm - C or D - 2**

Type      Size      Length      ØD1 (H7)      ØD2 (H7)      Disengagement Torque      Torque Range  
 C = Single Position    D = Multi Position Engagement

Size	Dimensions (mm)									Technical Data								
	ØD	L	Ø D1	Ø D2	Ø D3	Ø D4	F	L1	S	max. speed (1/min)	Mass (kg)	Moment of Inertia J (kg cm <sup>2</sup> )	Torque 98 Sh TKN (Nm)	Torque Range		Misalignment		
	Outer Ø	Length	Bore Size (H7) min~max	Bore Size (H7) min~max			Screw ISO4762 TA (Nm)							1 TKN (Nm)	2 TKN (Nm)	radial Δ Kr (mm)	axial Δ Ka (mm)	angular Δ Kw (°)
-14	49	65	6-16	6-16	30	40.5	M4 5.1	24	0.7	11690	0.22	0.5	12.5	3 - 7	5 - 10	0.09	+1.0 -0.5	0.9
-19	64	100	10-24	10-20 14#	40	56	M6 15	41	1.2	8950	0.77	3.2	17	5 - 15	10 - 30	0.06	+1.2 -0.5	0.9
-24	79	126.5	16-28	12-28 21#	55	66	M8 36	50	1.2	7630	1.34	8.2	60	12 - 35	20 - 60	0.10	+1.4 -0.5	0.9
-28	94	142	20-38	14-35 27#	65	82	M10 72	59	2	6030	3	26	160	50 - 130	65 - 150	0.11	+1.5 -0.7	0.9
-38	119	160	20-45	30-50 41#	80	110	M12 125	67	2	4980	5.7	86	325	60 - 200	150 - 300	0.12	+1.8 -0.7	0.9
-42	129	195	20-55	35-56 46#	95	122	M12 125	76	2	4440	10.5	186	450	80 - 250	200 - 500	0.14	+2.0 -1.0	0.9

**+** **Bores** > Ø D2 and ≤ D2\* only over LD

**Material** hubs: aluminium  
spider element: polyurethane 98 Sh A (red)

**Keyway** optional acc. DIN 6885  
biggest bore marked with a #

**Temperature Range** -30 °C ~ 90 °C

Size	14	19	24	28	38	42
D2*	20	26	31	38	57	62
LD	20	28	38	34	42	56

### Safety Coupling

with keyway and inner cone

optional  
nickel-plated version  
optional full stainless  
steel version

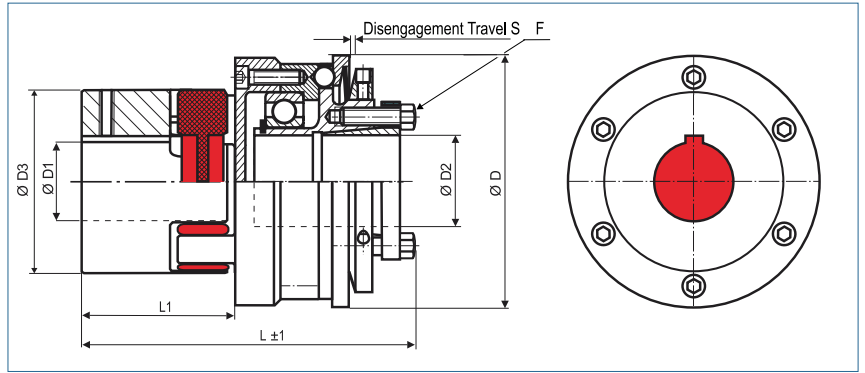

**Order Code**    **KBK/EPI - 24 - 111.5 - N16H7 - 15H7 - 20Nm - C or D - 2**

Type                      Size                      Length                      ØD1 (H7)                      ØD2 (H7)                      Disengagement Torque                      Torque Range

C = Single Position    D = Multi Position Engagement

Size	Dimensions (mm)									Technical Data							
	ØD	L	Ø D1	Ø D2	Ø D3	F	L1	S	max. speed (1/min)	Mass (kg)	Moment of Inertia J (kg cm <sup>2</sup> )	Torque 98 Sh TKN (Nm)	Torque Range		Misalignment		
	Outer Ø	Length	Bore Size (H7) min-max	Bore Size (H7) min-max		Screw ISO4017 TA (Nm)							1 TKN (Nm)	2 TKN (Nm)	radial Δ Kr (mm)	axial Δ Ka (mm)	angular Δ Kw (°)
-14	49	65	6-16	6-14 10#	30	M3 2.1	24	0.7	11690	0.22	0.5	12.5	3 - 7	5 - 10	0.09	+1.0 -0.5	0.9
-19	64	93	10-24	12-20 14#	40	M5 6	41	1.2	8950	0.72	2.9	17	5 - 15	10 - 30	0.06	+1.2 -0.5	0.9
-24	79	111.5	16-28	15-25 18#	55	M6 8.5	50	1.2	7630	1.3	7.9	60	12 - 35	20 - 60	0.10	+1.4 -0.5	0.9
-28	94	135	20-38	20-35 27#	65	M6 14	59	2	6030	2.28	20	160	50 - 130	65 - 150	0.11	+1.5 -0.7	0.9
-38	119	151	20-45	25-50 41#	80	M8 20	67	2	4980	4.6	69	325	60 - 200	150 - 300	0.12	+1.8 -0.7	0.9
-42	129	175	20-55	35-55 45#	95	M8 26	76	2	4440	8.75	156	450	80 - 250	200 - 500	0.14	+2.0 -1.0	0.9



**Material**                      inner cone: steel  
   hubs: aluminium  
   spider element: polyurethane 98 Sh A (red)

**Keyway**                      optional acc. DIN 6885  
   biggest bore marked with a #

**Temperature Range**      -30 °C ~ 90 °C



### Safety Coupling

with keyway and outer cone

optional  
nickel-plated version  
optional full stainless  
steel version

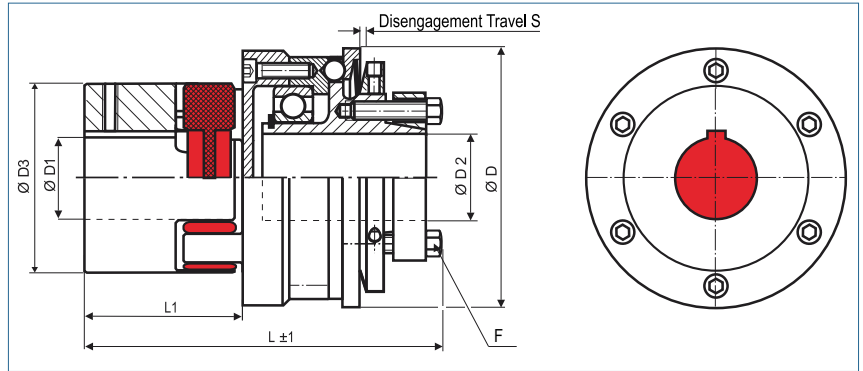

**Order Code**    **KBK/EPA - 24 - 119.5 - N16H7 - 15H7 - 20Nm - C or D - 2**

Type                      Size                      Length                      ØD1 (H7)                      ØD2 (H7)                      Disengagement Torque                      Torque Range  
 C = Single Position    D = Multi Position Engagement

Size	Dimensions (mm)									Technical Data							
	ØD	L	ØD1	ØD2	ØD3	F	L1	S	max. speed (1/min)	Mass (kg)	Moment of Inertia J (kg cm²)	Torque 98 Sh TKN (Nm)	Torque Range		Misalignment		
	Outer Ø	Length	Bore Size (H7) min~max	Bore Size (H7) von ~bis		Screw ISO4017 TA (Nm)							1 TKN (Nm)	2 TKN (Nm)	radial Δ Kr (mm)	axial Δ Ka (mm)	angular Δ Kw (°)
-14	49	67	6-16	5-14 10#	30	M3 2.1	24	0.7	11690	0.22	0.5	12.5	3 - 7	5 - 10	0.09	+1.0 -0.5	0.9
-19	64	96	10-24	12-20 14#	40	M5 5.9	41	1.2	8950	0.71	2.9	17	5 - 15	10 - 30	0.06	+1.2 -0.5	0.9
-24	79	119.5	16-28	15-25 18#	55	M5 8.7	50	1.2	7630	1.29	7.9	60	12 - 35	20 - 60	0.10	+1.4 -0.5	0.9
-28	94	144	20-38	20-35 27#	65	M6 15	59	2	6030	2.3	20.4	160	50 - 130	65 - 150	0.11	+1.5 -0.7	0.9
-38	119	160	20-45	25-50 41#	80	M8 25	67	2	4980	4.5	67.3	325	60 - 200	150 - 300	0.12	+1.8 -0.7	0.9
-42	129	189	20-55	35-55 45#	95	M8 36	76	2	4440	8.8	156.1	450	80 - 250	200 - 500	0.14	+2.0 -1.0	0.9

**Material**                      outer cone: steel  
    hubs: aluminium  
    spider element: polyurethane 98 Sh A (red)

**Keyway**                      optional acc. DIN 6885  
    biggest bore marked with a #

**Temperature Range**    -30 °C ~ 90 °C

## Safety Coupling

with collet clamp and keyway

optional  
nickel-plated version  
optional full stainless  
steel version

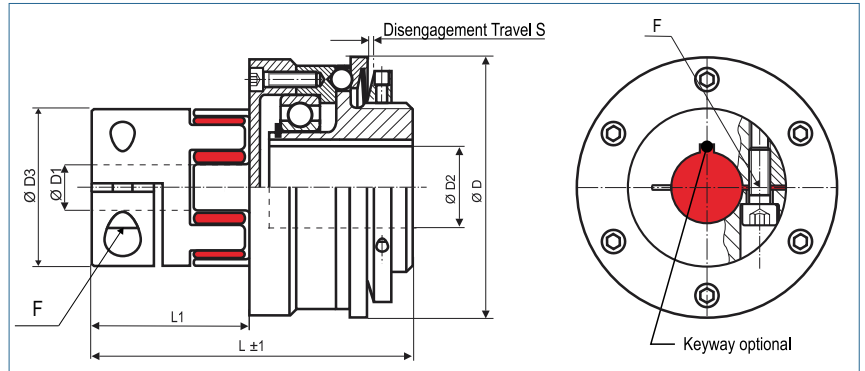

Order Code

**KBK/EKP - 24 - 98.5 - 16H7 - N15H7 - 20Nm - C or D - 2**

Type                      Size                      Length                      ØD1 (H7)                      ØD2 (H7)                      Disengagement Torque                      Torque Range

C = Single Position    D = Multi Position Engagement

Size	Dimensions (mm)								Technical Data								
	ØD	L	ØD1	ØD2	ØD3	F	L1	S	max. speed (1/min)	Mass (kg)	Moment of Inertia J (kg cm <sup>2</sup> )	Torque 98 Sh TKN (Nm)	Torque Range		Misalignment		
	Outer Ø	Length	Bore Size (H7) min~max	Bore Size (H7) min~max		Screw (ISO4762) TA (Nm)							1 TKN (Nm)	2 TKN (Nm)	radial Δ Kr (mm)	axial Δ Ka (mm)	angular Δ Kw (°)
-14	49	55	4-16	6-12	30	M3 1.4	24	0.7	11690	0.21	0.5	12.5	3 - 7	5 - 10	0.09	+1.0 -0.5	0.9
-19	64	81	10-22	10-16	40	M6/11	41	1.2	8950	0.65	2.7	17	5 - 15	10 - 30	0.06	+1.2 -0.5	0.9
		M6/11				33											
-24	79	98.5	15-32	15-24	55	M6/11	50	1.2	7630	1.24	7.6	60	12 - 35	20 - 60	0.10	+1.4 -0.5	0.9
		M6/11				40											
-28	94	121	19-38	19-29	65	M8/25	59	2	6030	2.1	18	160	50 - 130	65 - 150	0.11	+1.5 -0.7	0.9
		M8/25				45											
-38	119	134	20-45	20-42	80	M8/25	67	2	4980	3.8	57	325	60 - 200	150 - 300	0.12	+1.8 -0.7	0.9
		M10/49				53											
-42	129	157	28-45	20-50	95	M10	76	2	4440	5.9	104	450	80 - 250	200 - 500	0.14	+2.0 -1.0	0.9
						70											



<b>Material</b>	collet clamp: aluminium spider element: polyurethane 98 Sh A (red)
<b>Hub Style</b>	size 14 and 19: single slit** size 24, 28, 38 and 42: double slit ** short lengths are automatically with single slits
<b>Keyway</b>	optional acc. DIN 6885
<b>Temperature Range</b>	-30 °C ~ 90 °C

Safety Coupling

with two collet clamps

optional  
nickel-plated version  
optional full stainless  
steel version

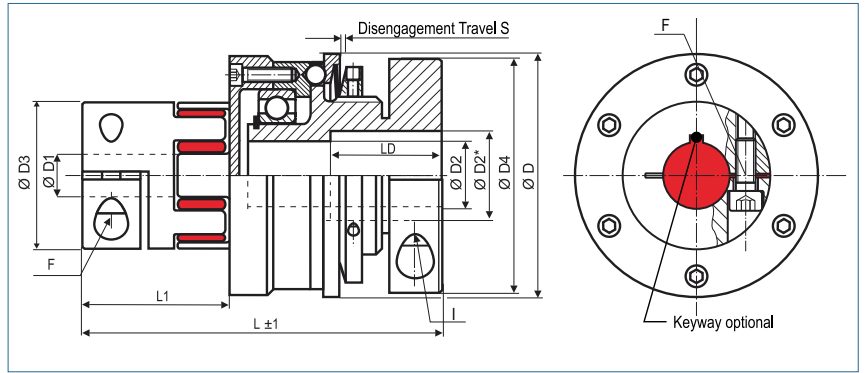

Order Code

**KBK/EKK - 24 - 126.5 - 16H7 - 14H7 - 20Nm - C or D - 2**

Type                      Size                      Length                      ØD1 (H7)                      ØD2 (H7)                      Disengagement Torque                      Torque Range

C = Single Position    D = Multi Position Engagement

Size	Dimensions (mm)										Technical Data								
	ØD	L	Ø D1	Ø D2	Ø D3	Ø D4	F	I	L1	S	max. speed (1/min)	Mass (kg)	Moment of Inertia J (kg cm <sup>2</sup> )	Torque 98 Sh TKN (Nm)	Torque Range		Misalignment		
	Outer Ø	Length	Bore Size (H7) min-max	Bore Size (H7) min-max			Screw ISO4762 TA (Nm)	Screw ISO4762 TA (Nm)							1 TKN (Nm)	2 TKN (Nm)	radial Δ Kr (mm)	axial Δ Ka (mm)	angular Δ Kw (°)
-14	49	65	4-16	6-16 11#	30	40.5	M3 1.4	M4 5.1	24	0.7	11690	0.24	0.6	12.5	3 - 7	5 - 10	0.09	+1.0 -0.5	0.9
-19	64	100	10-22	10-20	40	56	M6/11	M6	41	1.2	8950	0.79	3.2	17	5 - 15	10 - 30	0.06	+1.2 -0.5	0.9
		92		14#			15	33											
-24	79	126.5	15-32	12-28	55	66	M6/11	M8	50	1.2	7630	1.46	8.9	60	12 - 35	20 - 60	0.10	+1.4 -0.5	0.9
		116.5		21#			36	40											
-28	94	142	19-38	14-35	65	82	M8/25	M10	59	2	6030	3.1	27	160	50 - 130	65 - 150	0.11	+1.5 -0.7	0.9
		128		27#			72	45											
-38	119	160	20-45	30-50	80	110	M8/25	M12	67	2	4980	5.7	86	325	60 - 200	150 - 300	0.12	+1.8 -0.7	0.9
		146		41#			125	59											
-42	129	195	28-45	35-56	95	122	M10	M12	76	2	4440	8.5	150	450	80 - 250	200 - 500	0.14	+2.0 -1.0	0.9
							46#	70	125										



**Bores** > Ø D2 and ≤ D2\* only over LD

**Material** collet clamp: aluminium  
spider element: polyurethane 98 Sh A (red)

**Hub Style** size 14 and 19: single slit\*\*  
size 24, 28, 38 and 42: double slit  
\*\* short lengths are automatically with single slits

**Keyway** optional acc. DIN 6885  
biggest bore marked with a #

**Temperature Range** -30 °C ~ 90 °C

Size	14	19	24	28	38	42
D2*	20	26	31	38	57	62
LD	20	28	38	34	42	56

### Safety Coupling

with collet clamp and inner cone

optional  
nickel-plated version  
optional full stainless  
steel version

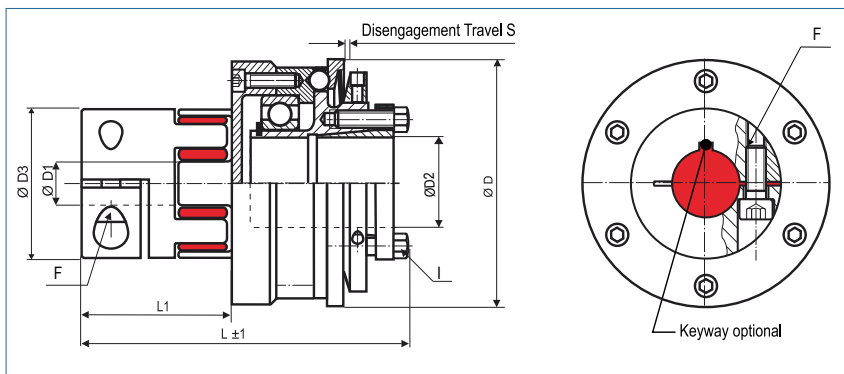

Order Code

**KBK/EKI - 24 - 111.5 - 16H7 - 15H7 - 20Nm - C or D - 2**

Type      Size      Length      ØD1 (H7)      ØD2 (H7)      Disengagement Torque      Torque Range  
 C = Single Position    D = Multi Position Engagement

Size	Dimensions (mm)									Technical Data								
	ØD	L	Ø D1	Ø D2	Ø D3	F	I	L1	S	max. speed (1/min)	Mass (kg)	Moment of Inertia J (kg cm <sup>2</sup> )	Torque 98 Sh TKN (Nm)	Torque Range		Misalignment		
	Outer Ø	Length	Bore Size (H7) min~max	Bore Size (H7) min~max		Screw ISO4762 TA (Nm)	Screw ISO4017 TA (Nm)							1 TKN (Nm)	2 TKN (Nm)	radial Δ Kr (mm)	axial Δ Ka (mm)	angular Δ Kw (°)
-14	49	65	4-16	6-14 10#	30	M3 1.4	M3 2.1	24	0.7	11690	0.24	0.6	12.5	3 - 7	5 - 10	0.09	+1.0 -0.5	0.9
-19	64	93	10-22	12-20	40	M6/11	M5	41	1.2	8950	0.74	3.0	17	5 - 15	10 - 30	0.06	+1.2 -0.5	0.9
		85		14#		6	33											
-24	79	111.5	15-32	15-25	55	M6/11	M6	50	1.2	7630	1.42	8.7	60	12 - 35	20 - 60	0.10	+1.4 -0.5	0.9
		101.5		18#		8.5	40											
-28	94	135	19-38	20-35	65	M8/25	M6	59	2	6030	2.4	21	160	50 - 130	65 - 150	0.11	+1.5 -0.7	0.9
		121		27#		14	45											
-38	119	151	20-45	25-50	80	M8/25	M8	67	2	4980	4.6	69	325	60 - 200	150 - 300	0.12	+1.8 -0.7	0.9
		137		41#		20	53											
-42	129	175	28-45	35-55	95	M10	M8	76	2	4440	6.7	120	450	80 - 250	200 - 500	0.14	+2.0 -1.0	0.9
						45#	70	26										

<b>Material</b>	inner cone: steel collet clamp: aluminium spider element: polyurethane 98 Sh A (red)
<b>Hub Style</b>	size 14 and 19: single slit** size 24, 28, 38, 42: double slit ** short lengths are automatically with single slits
<b>Keyway</b>	optional acc. DIN 6885 biggest bore marked with a #
<b>Temperature Range</b>	-30 °C ~ 90 °C

## Safety Coupling

with collet clamp and outer cone

optional  
nickel-plated version  
optional full stainless  
steel version

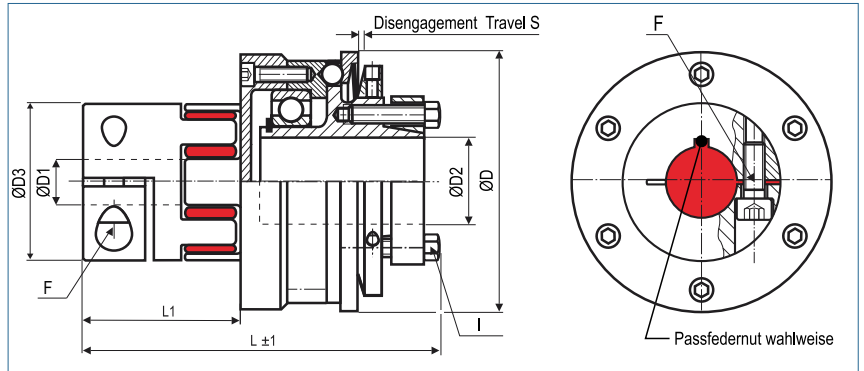

Order Code

**KBK/EKA - 24 - 119.5 - 16H7 - 14H7 - 20Nm - C or D - 2**

Type      Size      Length      ØD1 (H7)      ØD2 (H7)      Disengagement Torque      Torque Range

C = Single Position    D = Multi Position Engagement

Size	Dimensions (mm)									Technical Data								
	ØD	L	Ø D1	Ø D2	Ø D3	F	I	L1	S	max. speed (1/min)	Mass (kg)	Moment of Inertia J (kg cm <sup>2</sup> )	Torque 98 Sh TKN (Nm)	Torque Range		Misalignment		
	Outer Ø	Length	Bore Size (H7) min~max	Bore Size (H7) min~max		Screw ISO4762 TA (Nm)	Screw ISO4017 TA (Nm)							1 TKN (Nm)	2 TKN (Nm)	radial Δ Kr (mm)	axial Δ Ka (mm)	angular Δ Kw (°)
-14	49	67	4-16	5-14 10#	30	M3 1.4	M3 2.1	24	0.7	11690	0.24	0.6	12.5	3 - 7	5 - 10	0.09	+1.0 -0.5	0.9
-19	64	96	10-22	12-20	40	M6/11	M5	41	1.2	8950	0.73	3.0	17	5 - 15	10 - 30	0.06	+1.2 -0.5	0.9
		88		14#		M6/11	5.9	33										
-24	79	119.5	15-30	15-25	55	M6/11	M5	50	1.2	7630	1.41	8.6	60	12 - 35	20 - 60	0.10	+1.4 -0.5	0.9
		109.5		18#		M6/11	8.7	40										
-28	94	144	19-38	20-35	65	M8/25	M6	59	2	6030	2.4	21	160	50 - 130	65 - 150	0.11	+1.5 -0.7	0.9
		130		27#		M8/25	15	45										
-38	119	160	20-45	25-50	80	M8/25	M8	67	2	4980	4.5	67	325	60 - 200	150 - 300	0.12	+1.8 -0.7	0.9
		146		41#		M10/49	25	53										
-42	129	189	28-45	35-55	95	M10	M8	76	2	4440	6.8	120	450	80 - 250	200 - 500	0.14	+2.0 -1.0	0.9
				45#		70	36											



<b>Material</b>	outer cone: steel collet clamp: aluminium spider element: polyurethane 98 Sh A (red)
<b>Hub Style</b>	size 14 and 19: single slit** size 24, 28, 38, 42: double slit ** short lengths are automatically with single slits
<b>Keyway</b>	optional acc. DIN 6885 biggest bore marked with a #
<b>Temperature Range</b>	-30 °C ~ 90 °C

# Safety Coupling

with split hubs

optional  
nickel-plated version  
optional full stainless  
steel version

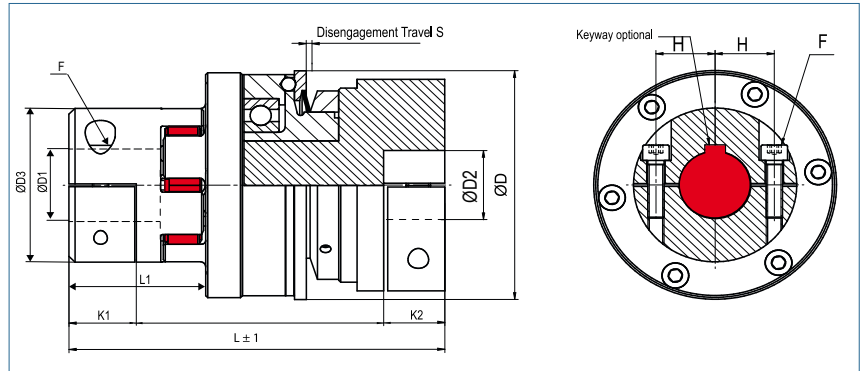

Order Code

**KBK/EHH - 24 - 136 - 20H7 - 30H7 - 20Nm - C or D - 1**

Type                      Size                      Length                      ØD1 (H7)                      ØD2 (H7)                      Disengagement Torque                      Torque Range

C = Single Position    D = Multi Position Engagement

Size	Dimensions (mm)											Technical Data								
	ØD	L	Ø D1	Ø D2	Ø D3	K1	F	I	L1	S	W	max. speed (1/min)	Mass (kg)	Moment of Inertia J (kg cm <sup>2</sup> )	Torque 98 Sh TKN (Nm)	Torque Range		Misalignment		
	Outer Ø	Length	Bore Size (H7) min-max	Bore Size (H7) min-max		K2	Screw (ISO4762) TA (Nm)	Screw (ISO4762) TA (Nm)								1 TKN (Nm)	2 TKN (Nm)	radial Δ Kr (mm)	axial Δ Ka (mm)	angular Δ Kw (°)
-14	49	73	4-14	6-25	30	8	M4	M4	24	0.7	56	11690	0,39	1,2	12,5	3 - 7	5 - 10	0.09	+1.0	0.9
-19	64	112	8-20	10-32	40	19	M6	M6	40	1.2	75	8950	0,98	4,3	17	5 - 15	10 - 30	0.06	+1.2	0.9
				30*		17	10	15											-0.5	
-24	79	136	10-28	12-35	55	22	M6	M8	50	1.2	92	7630	1,84	12,2	60	12 - 35	20 - 60	0.10	+1.4	0.9
						22	10	40											-0.5	
-28	94	160	14-38	12-44	65	25	M8	M10	59	2	110	6030	2,94	28,8	160	50 - 130	65 - 150	0.11	+1.5	0.9
						24	25	72											-0.7	
-38	119	185	18-45	30-50	80	33	M8	M12	67	2	122	4980	5,8	92	325	60 - 200	150 - 300	0.12	+1.8	0.9
						30	25	125											-0.7	
-42	129	215	22-50	25-65	95	36	M10	M12	76	2	143	4440	9,47	190	450	80 - 250	200 - 500	0.14	+2.0	0.9
						35	49	125											-1.0	



**Material**                      collet clamp: aluminium  
spider element: polyurethane 98 Sh A (red)

**Keyway**                      optional acc. DIN 6885  
biggest bore marked with a #

**Temperature Range**      -30 °C ~ 120 °C

## Safety Coupling

with outer cone and keyway

optional  
nickel-plated version  
optional full stainless  
steel version

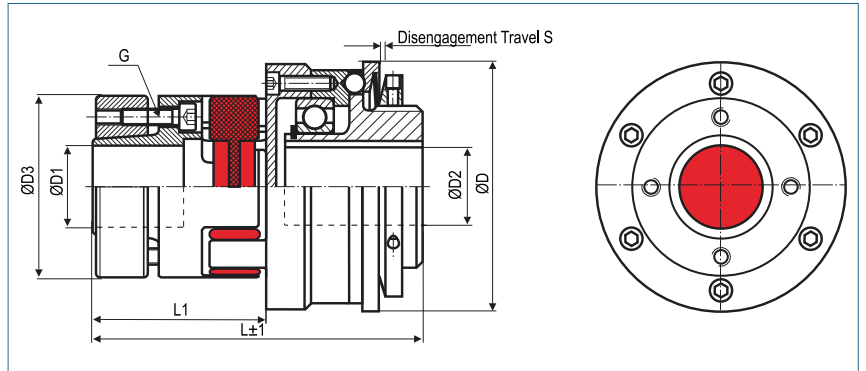

Order Code

**KBK/EAP - 24 - 98.5 - 16H7 - N15H7 - 20Nm - C or D - 2**

Type      Size      Length      ØD1 (H7)      ØD2 (H7)      Disengagement Torque      Torque Range  
 C = Single Position    D = Multi Position Engagement

Size	Dimensions (mm)								Technical Data								
	ØD	L	Ø D1	Ø D2	Ø D3	G	L1	S	max. speed (1/min)	Mass (kg)	Moment of Inertia J (kg cm <sup>2</sup> )	Torque 98 Sh TKN (Nm)	Torque Range		Misalignment		
	Outer Ø	Length	Bore Size (H7) min~max	Bore Size (H7) min~max		Screw ISO4762 TA (Nm)							1 TKN (Nm)	2 TKN (Nm)	radial Δ Kr (mm)	axial Δ Ka (mm)	angular Δ Kw (°)
-14	49	63	6-14	6-13	30	M3	32	0.7	11690	0.26	0.6	12.5	3 - 7	5 - 10	0.09	+1.0	0.9
		58	10#			1.34	27						-0.5				
-19	64	81	10-19	10-16	40	M4	41	1.2	8950	0.71	2.9	17	5 - 15	10 - 30	0.06	+1.2	0.9
		76	13#			2.9	36						-0.5				
-24	79	98.5	15-28	15-24	55	M5	50	1.2	7630	1.45	8.9	60	12 - 35	20 - 60	0.10	+1.4	0.9
		91.5	18#			6	43						-0.5				
-28	94	121	19-38	19-29	65	M5	59	2	6030	2.4	21	160	50 - 130	65 - 150	0.11	+1.5	0.9
		114	30#			6	52						-0.7				
-38	119	135	20-45	20-42	80	M6	67	2	4980	4.6	69	325	60 - 200	150 - 300	0.12	+1.8	0.9
		126	37#			10	58						-0.7				
-42	129	157	28-50	20-50	95	M8	76	2	4440	8.9	158	450	80 - 250	200 - 500	0.14	+2.0	0.9
		145.5	41#			35	64						-1.0				



**Material**      collet clamp: aluminium  
 outer cone: steel  
 spider element: polyurethane 98 Sh A (red)

**Keyway**      optional acc. DIN 6885  
 biggest bore marked with a #

**Temperature Range**    -30 °C ~ 90 °C

## Safety Coupling

with outer cone and collet clamp

optional  
nickel-plated version  
optional full stainless  
steel version

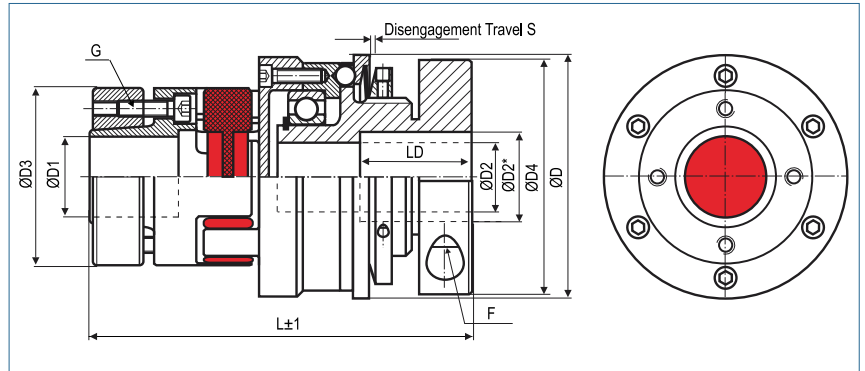

Order Code

**KBK/EAK - 24 - 126.5 - 16H7 - 14H7 - 20Nm - C or D - 2**

Type                      Size                      Length                      ØD1 (H7)                      ØD2 (H7)                      Disengagement Torque                      Torque Range  
 C = Single Position    D = Multi Position Engagement

Size	Dimensions (mm)										Technical Data								
	ØD	L	Ø D1	Ø D2	Ø D3	Ø D4	G	F	L1	S	max. speed (1/min)	Mass (kg)	Moment of Inertia J (kg cm <sup>2</sup> )	Torque 98 Sh TKN (Nm)	Torque Range		Misalignment		
	Outer Ø	Length	Bore Size (H7) min-max	Bore Size (H7) min-max			Screw ISO4762 TA (Nm)	Screw ISO4762 TA (Nm)							1 TKN (Nm)	2 TKN (Nm)	radial Δ Kr (mm)	axial Δ Ka (mm)	angular Δ Kw (°)
-14	49	73	6-14	6-16	30	40.5	M3	M4	32	0.7	11690	0.29	0.7	12.5	3 - 7	5 - 10	0.09	+1.0	0.9
		68	10#	11#			1.34	5	27						-0.5				
-19	64	100	10-19	10-20	40	56	M4	M6	41	1.2	8950	0.85	3.5	17	5 - 15	10 - 30	0.06	+1.2	0.9
		95	13#	14#			2.9	15	36						-0.5				
-24	79	126.5	15-25	12-28	55	66	M5	M8	50	1.2	7630	1.67	10.2	60	12 - 35	20 - 60	0.10	+1.4	0.9
		119.5	18#	21#			6	36	43						-0.5				
-28	94	142	19-38	14-35	65	82	M5	M10	59	2	6030	3.4	30	160	50 - 130	65 - 150	0.11	+1.5	0.9
		135	30#	27#			6	72	52						-0.7				
-38	119	160	20-45	30-50	80	110	M6	M12	67	2	4980	6.5	98	325	60 - 200	150 - 300	0.12	+1.8	0.9
		151	37#	41#			10	125	58						-0.7				
-42	129	195	28-50	35-56	95	122	M8	M12	76	2	4440	11.5	204	450	80 - 250	200 - 500	0.14	+2.0	0.9
		183	41#	46#			35	125	64						-1.0				

**Bore** > Ø D2 and ≤ D2\* only over LD

**Material** collet clamp: aluminium  
outer cone: steel  
spider element: polyurethane 98 Sh A (red)

**Keyway** optional acc. DIN 6885  
biggest bore marked with a #

**Temperature Range** -30 °C ~ 90 °C

Size	14	19	24	28	38	42
D2*	20	26	31	38	57	62
LD	20	28	38	34	42	56



### Safety Coupling

with outer cone and inner cone

optional  
nickel-plated version  
optional full stainless  
steel version

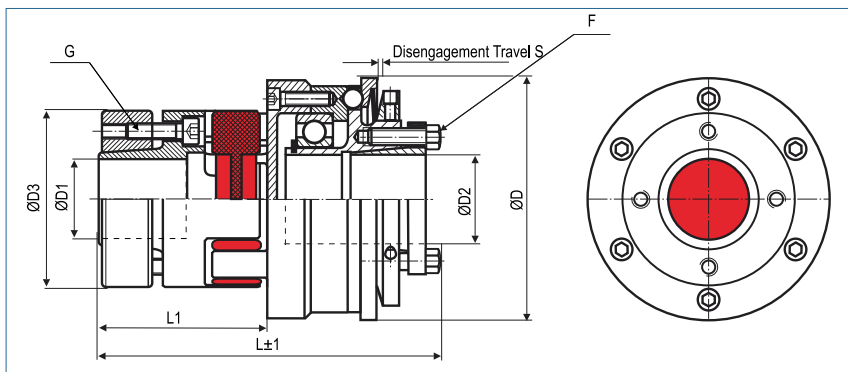

Order Code

**KBK/EAI - 24 - 111.5 - 16H7 - 15H7 - 20Nm - C or D - 2**

Type      Size      Length      ØD1 (H7)      ØD2 (H7)      Disengagement Torque      Torque Range

C = Single Position    D = Multi Position Engagement

Size	Dimensions (mm)									Technical Data								
	ØD	L	Ø D1	Ø D2	Ø D3	G	F	L1	S	max. speed (1/min)	Mass (kg)	Moment of Inertia J (kg cm <sup>2</sup> )	Torque 98 Sh TKN (Nm)	Torque Range		Misalignment		
	Outer Ø	Length	Bore Size (H7) min-max	Bore Size (H7) min-max		Screw ISO4762 TA (Nm)	Screw ISO4017 TA (Nm)							1 TKN (Nm)	2 TKN (Nm)	radial Δ Kr (mm)	axial Δ Ka (mm)	angular Δ Kw (°)
-14	49	73	6-14	6-14	30	M3	M3	32	0.7	11690	0.29	0.7	12.5	3 - 7	5 - 10	0.09	+1.0	0.9
		68	10#	10#		1.34	2.1	27	-0.5									
-19	64	93	10-19	12-20	40	M4	M5	41	1.2	8950	0.80	3.3	17	5 - 15	10 - 30	0.06	+1.2	0.9
		88	13#	14#		2.9	6	36	-0.5									
-24	79	111.5	15-25	15-25	55	M5	M6	50	1.2	7630	1.63	10	60	12 - 35	20 - 60	0.10	+1.4	0.9
		104.5	18#	18#		6	8.5	43	-0.5									
-28	94	135	19-38	20-35	65	M5	M6	59	2	6030	2.7	24	160	50 - 130	65 - 150	0.11	+1.5	0.9
		128	30#	27#		6	14	52	-0.7									
-38	119	152	20-45	25-45	80	M6	M8	67	2	4980	5.4	81	325	60 - 200	150 - 300	0.12	+1.8	0.9
		143	37#	37#		10	20	58	-0.7									
-42	129	175	28-50	35-55	95	M8	M8	76	2	4440	9.7	173	450	80 - 250	200 - 500	0.14	+2.0	0.9
		163.5	42#	45#		35	26	64	-1.0									



<b>Material</b>	inner cone: steel collet clamp: aluminium outer cone: steel spider element: polyurethane 98 Sh A (red)
<b>Keyway</b>	optional acc. DIN 6885 biggest bore marked with a #
<b>Temperature Range</b>	-30 °C ~ 90 °C

### Safety Coupling

with two outer cones

optional  
nickel-plated version  
optional full stainless  
steel version

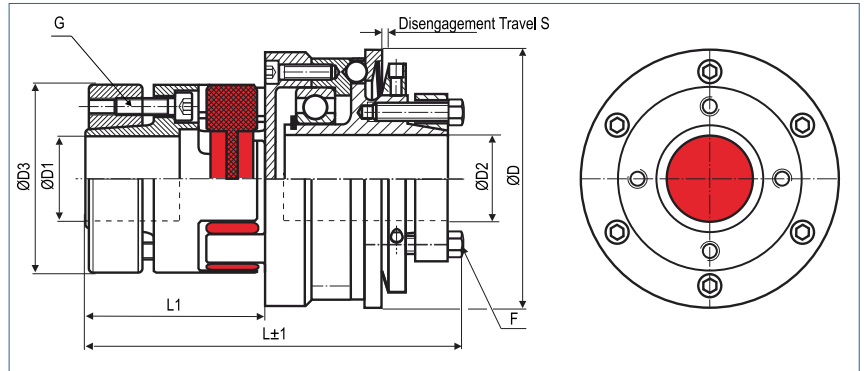

Order Code

**KBK/EAA - 24 - 119.5 - 16H7 - 15H7 - 20Nm - C or D - 2**

Type                      Size                      Length                      ØD1 (H7)                      ØD2 (H7)                      Disengagement Torque                      Torque Range  
 C = Single Position    D = Multi Position Engagement

Size	Dimensions (mm)									Technical Data								
	ØD	L	Ø D1	Ø D2	Ø D3	G	F	L1	S	max. speed (1/min)	Mass (kg)	Moment of Inertia J (kg cm <sup>2</sup> )	Torque 98 Sh TKN (Nm)	Torque Range		Misalignment		
	Outer Ø	Length	Bore Size (H7) min~max	Bore Size (H7) min~max		Screw ISO4762 TA (Nm)	Screw ISO4017 TA (Nm)							1 TKN (Nm)	2 TKN (Nm)	radial Δ Kr (mm)	axial Δ Ka (mm)	angular Δ Kw (°)
-14	49	75	6-14	5-14	30	M3	M3	32	0.7	11690	0.29	0.7	12.5	3 - 7	5 - 10	0.09	+1.0	0.9
		70	10#	10#		1.34	2.1	27						-0.5				
-19	64	96	10-19	12-20	40	M4	M5	41	1.2	8950	0.79	3.2	17	5 - 15	10 - 30	0.06	+1.2	0.9
		91	13#	14#		2.9	6	36						-0.5				
-24	79	119.5	15-28	15-25	55	M5	M5	50	1.2	7630	1.62	9.9	60	12 - 35	20 - 60	0.10	+1.4	0.9
		112.5	21#	18#		6	8.7	43						-0.5				
-28	94	143.5	19-38	20-35	65	M5	M6	59	2	6030	2.8	24	160	50 - 130	65 - 150	0.11	+1.5	0.9
		136.5	30#	27#		6	15	52						-0.7				
-38	119	160	20-45	25-50	80	M6	M8	67	2	4980	5.3	79	325	60 - 200	150 - 300	0.12	+1.8	0.9
		151	37#	42#		10	25	58						-0.7				
-42	129	189	28-50	35-55	95	M8	M8	76	2	4440	9.8	174	450	80 - 250	200 - 500	0.14	+2.0	0.9
		177.5	42#	45#		35	36	64						-1.0				

**Material**                      outer cone: steel  
 outer cone: steel  
 spider element: polyurethane 98 Sh A (red)

**Keyway**                      optional acc. DIN 6885  
 biggest bore marked with a #

**Temperature Range**      -30 °C ~ 90 °C

## Spider Elements for Couplings Type KBE

Type KBE series

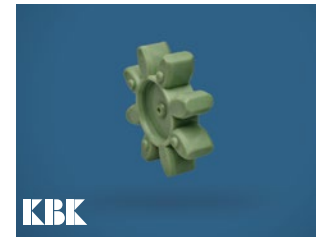
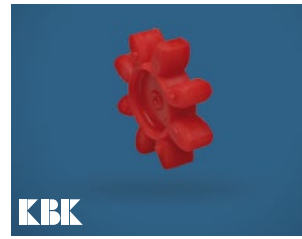

**80 ShoreA**  
operating temperature:  
-50 to +80  
peak temperature: -60 to +120

**92 ShoreA**  
operating temperature:  
-30 to +90  
peak temperature: -50 to +120

**98 ShoreA**  
operating temperature:  
-30 to +90  
peak temperature: -40 to +120

**64 ShoreD**  
operating temperature:  
-20 to +110  
peak temperature: -30 to +120

Size	Hardness	Torque [Nm]		Torsional Stiffness Static [Nm/rad]	Torsional Stiffness Dynamic [Nm/rad]	Spring Stiffness radial [N/mm]	Misalignment			max. Bore [mm]
		TK nom.	TK max				axial [mm]	radial [mm]	angular [Grad]	
5	92 ShA	0.5	0.6	5.16	16	154	+0.4 / -0.2	0.06	1.0°	3
	80 ShA	0.7	1.4	8.6	26	114	+0.6 / -0.3	0.15	1.1°	
7	92 ShA	1.2	2.4	14.3	43	219	+0.6 / -0.3	0.10	1.0°	3
	98 ShA	2	4	22.9	69	421	+0.6 / -0.3	0.10	1.0°	
	64 ShD	2.4	4.8	34.3	103	630	+0.6 / -0.3	0.04	0.8°	
	80 ShA	1.8	3.6	17.2	52	125	+0.8 / -0.4	0.2	1.1°	
9	92 ShA	3	6	31.5	95	262	+0.8 / -0.4	0.15	1.0°	7
	98 ShA	5	10	51.6	155	518	+0.8 / -0.4	0.1	0.9°	
	64 ShD	6	12	74.6	224	739	+0.8 / -0.4	0.05	0.8°	
	80 ShA	3	6	84.3	252	274	+0.9 / -0.4	0.20	1.1°	
12	92 ShA	5	10	160.4	482	470	+0.9 / -0.4	0.14	1.0°	8
	98 ShA	9	18	240.7	718	846	+0.9 / -0.4	0.08	0.9°	
	64 ShD	12	24	327.9	982	1198	+0.9 / -0.4	0.05	0.8°	
	80 ShA	4	8	60.2	180	153	+1.0 / -0.5	0.21	1.1°	
14	92 ShA	7.5	15	114.6	344	336	+1.0 / -0.5	0.15	1.0°	10
	98 ShA	12.5	25	171.9	513	654	+1.0 / -0.5	0.09	0.9°	
	64 ShD	16	32	234.2	702	856	+1.0 / -0.5	0.06	0.8°	
	80 ShA	6	12	618	1065	582	+1.2 / -0.5	0.15	1.1°	
19	92 ShA	12	24	1090	1815	1120	+1.2 / -0.5	0.10	1.0°	18
	98 ShA	21	42	1512	2540	2010	+1.2 / -0.5	0.06	0.9°	
	64 ShD	26	52	2560	3810	2930	+1.2 / -0.5	0.04	0.8°	
	80 ShA	17	34	860	1390	840	+1.4 / -0.5	0.2	1.0°	
24	92 ShA	35	70	2300	5130	1900	+1.4 / -0.5	0.15	1.0°	27
	98 ShA	60	120	3700	8130	2940	+1.4 / -0.5	0.11	0.9°	
	64 ShD	75	150	5030	11500	4200	+1.4 / -0.5	0.08	0.8°	
	80 ShA	46	92	1370	2350	990	+1.5 / -0.7	0.2	1.3°	
28	92 ShA	95	190	4080	6745	1780	+1.5 / -0.7	0.15	1.0°	30
	98 ShA	160	320	6410	9920	3200	+1.5 / -0.7	0.11	0.9°	
	64 ShD	200	400	10260	20177	4348	+1.5 / -0.7	0.08	0.8°	
	92 ShA	190	380	6525	12000	2350	+1.8 / -0.7	0.17	1.0°	
38	98 ShA	325	650	11800	21850	4400	+1.8 / -0.7	0.12	0.9°	38
	64 ShD	405	810	26300	40335	6474	+1.8 / -0.7	0.09	0.8°	
	92 ShA	265	530	10870	20500	4100	+2.0 / -1.0	0.19	1.0°	
42	98 ShA	450	900	21594	37692	5940	+2.0 / -1.0	0.14	0.9°	46
	64 ShD	560	1120	36860	71400	7590	+2.0 / -1.0	0.10	0.8°	
	92 ShA	310	620	12968	22800	4500	+2.1 / -1.0	0.23	1.0°	
48	98 ShA	525	1050	25759	49400	6820	+2.1 / -1.0	0.16	0.9°	51
	64 ShD	655	1310	57630	102800	9000	+2.1 / -1.0	0.11	0.8°	
	92 ShA	310	620	12968	22800	4500	+2.1 / -1.0	0.23	1.0°	

Please contact us for our catalogues  
for **SERVO COUPLINGS** and  
**SHAFT HUB CONNECTIONS**



**KBK Antriebstechnik GmbH**

Unterlandstraße 46

63911 Klingenberg am Main

Germany

Phone: +49 9372 94061-0

Fax: +49 9372 94061-29

[info@kbk-antriebstechnik.de](mailto:info@kbk-antriebstechnik.de)

[www.kbk-antriebstechnik.de](http://www.kbk-antriebstechnik.de)

optional full stainless steel version

Permanent magnet coupling

with collet clamps

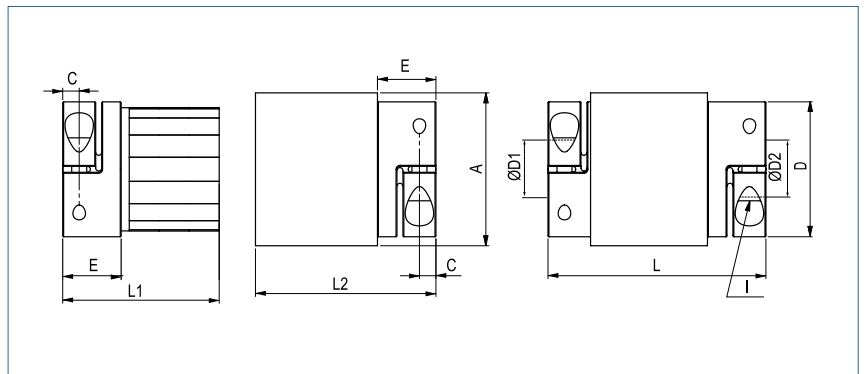
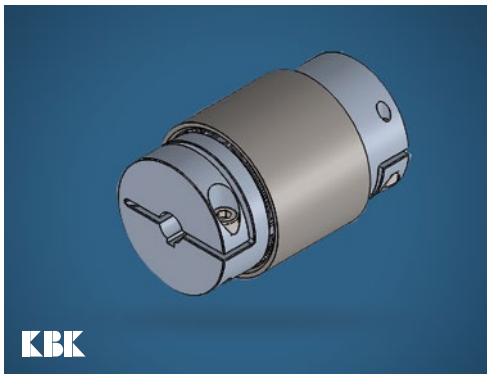

Order Code **PMK - 18 - 16 - 20**  
 Type            Size            ØD1 (H7)            ØD2 (H7)

Size	Torque TKN (Nm)	Dimensions (mm)										Technical Data						
		L Length	Ø A Outer	D1/D2 Bore Size (H7) min-max	L1	L2	H	C	E	Magnet-length	Hub Ø	I Screw (ISO4762) TA (Nm)	Mass Inner-part (kg)	Mass Outer-part (kg)	Inertia Innerpart (g m²)	Inertia Outerpart (g m²)	Misalignment radial ΔKr (mm)	max speed min-1
2	1.2	55	31	3-14	39	41	9	3.5	11	20	25	M3 2	0.07	0.11	0.005	0.018	0.5	10000
4	2.5	58	38	6-18	40	42	12	5	13	20	32.5	M4 3.5	0.11	0.15	0.01	0.04	0.5	9000
10	5	58	46	6-25	39.5	41.5	15.5	5	13.5	20	40.5	M4 4.5	0.16	0.2	0.04	0.08	0.5	8000
18	9	78	51	10-25.4	53.5	58.5	17	5,5	19,5	30	45	M5 8	0.23	0.28	0.07	0.14	0.5	7000
30	13	88	56	10-32	58.5	63.5	20	7,5	24.5	36	56	M6 15	0.28	0.35	0.1	0.21	0.5	6000
60	30	107	67	12-35	73	78	23	10	29	40	66	M8 40	0.53	0.7	0.3	0.6	0.5	5000
150	60	130	84	12-44	91.5	93.5	28	11	33.5	50	82	M10 84	0.9	1.5	1.1	1.3	0.4	4000

**Material**                      Clamping hub: aluminium  
     Magnetic media: stainless steel

**Keyway**                        optional acc. DIN 6885

**Range of temperature**    -30 °C ~ 100 °C

**Characteristics**            wear-free  
     maintenance-free  
     The coupling consists of 2 separated halves; the bearing has to be provided by the customer  
     Infinitely variable torque adjustable by immersion depth  
     In case of overload the power transmission will be separated from the inner and outer part (by slightly jerking)

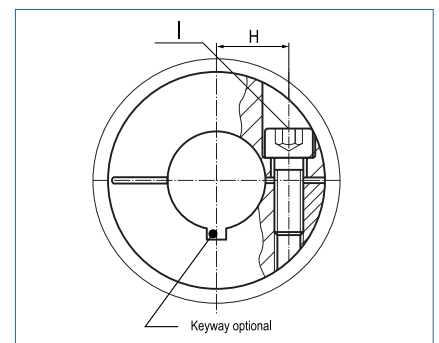

optional full stainless steel version

## Hysteresis magnet coupling

with collet clamps

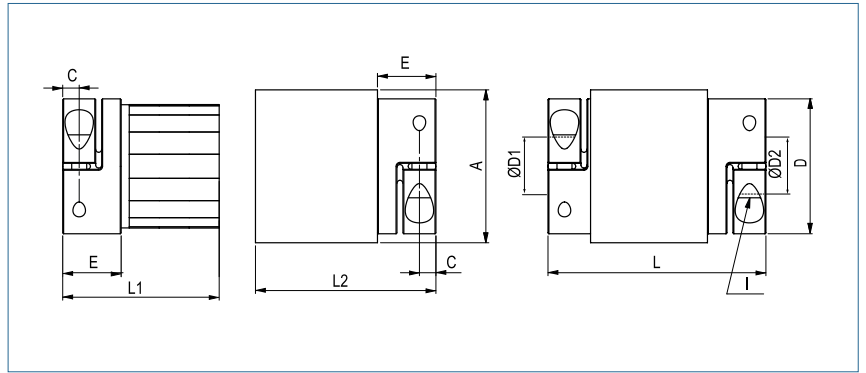
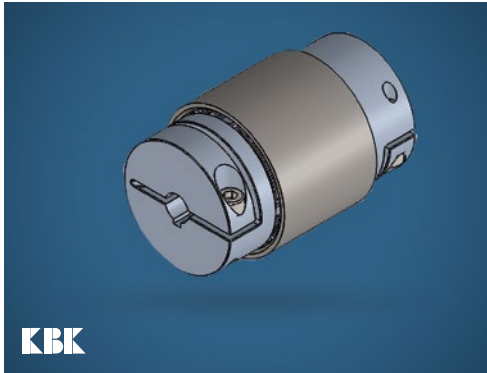

Order Code

**HMK - 18 - 16 - 20**

Type                      Size                      ØD1 (H7)                      ØD2 (H7)

Size	Torque TKN (Nm)	Dimensions (mm)										Technical Data						
		L Length	Ø A Outer	D1/D2 Bore Size (H7) min-max	L1	L2	H	C	E	Magnet-length	Hub Ø	I Screw (ISO4762) TA (Nm)	Mass Inner-part (kg)	Mass Outer-part (kg)	Inertia Innerpart (g m <sup>2</sup> )	Inertia Outerpart (g m <sup>2</sup> )	Misalignment radial ΔKr (mm)	max speed min-1
2	0.1	55	31	3-14	39	41	9	3.5	11	20	25	M3 2	0.07	0.11	0.005	0.018	0.2	10000
4	0.2	58	38	6-18	40	42	12	5	13	20	32.5	M4 3.5	0.11	0.15	0.01	0.04	0.2	9000
10	0.4	58	46	6-25	39.5	41.5	15.5	5	13.5	20	40.5	M4 4.5	0.16	0.2	0.04	0.08	0.2	8000
18	0.9	78	51	10-25.4	53.5	58.5	17	5.5	19.5	30	45	M5 8	0.23	0.28	0.07	0.14	0.2	7000
30	1.2	88	56	10-32	58.5	63.5	20	7.5	24.5	36	56	M6 15	0.28	0.35	0.1	0.21	0.2	6000
60	2.5	107	67	12-35	73	78	23	10	29	40	66	M8 40	0.53	0.7	0.3	0.6	0.2	5000
150	5	130	84	12-44	91.5	93.5	28	11	33.5	50	82	M10 84	0.9	1.5	1.1	1.3	0.2	4000

<b>Material</b>	Clamping hub: aluminium Magnetic media: stainless steel
<b>Keyway</b>	optional acc. DIN 6885
<b>Range of temperature</b>	-30 °C ~ 100 °C
<b>Popwer dissipation</b>	$P_v = (T \times n_s) / 9.55$

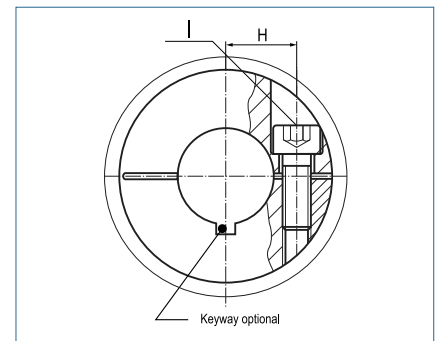

<b>Characteristics</b>	wear-free maintenance-free The coupling consists of 2 separated halves; the bearing has to be provided by the customer Infinitely variable torque adjustable by immersion depth In case of overload the power transmission will be separated from the inner and outer part (by slightly jerking)
------------------------	--

max. Power dissipation							
Size	2	4	10	18	30	60	150
<b>P<sub>VMAX</sub></b>	4	5	7	12	14	20	30