



Linear system **QSZ 60, 80, 100, 125**

BELT DRIVE

-  **HIGH LOAD CAPACITY**
-  **LONG TRAVERSE PATH > 6000 MM**
-  **CLEAN ROOM**

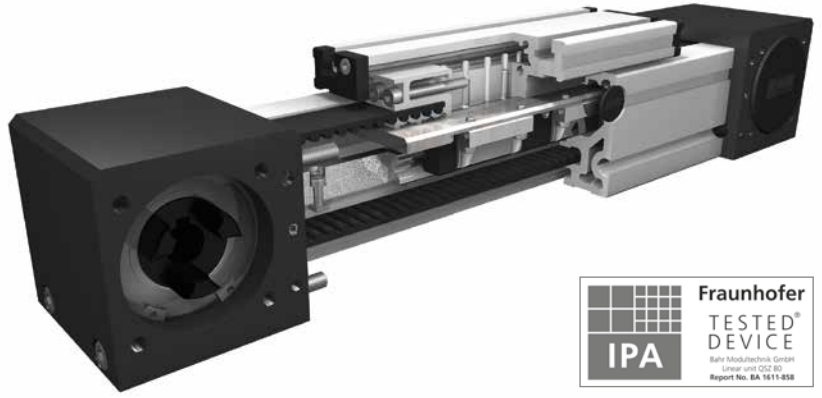
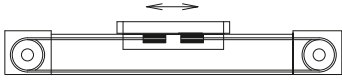

Function:

This unit consists of a square aluminium profile with an integrated ball rail. The carriage is moved by a belt drive. Each standard pulley includes one coupling claw on one side. Belt tension can be readjusted by a simple screw adjustment device in the carriage. This device can also be used for symmetrical adjustment of two or more linear units running parallel. This linear unit is suitable for application in clean rooms of clean-room classification 1.000 (corresponding to US Fed. Standard 209 E). With this series, multi-part assembled units with long strokes can be realized.

Fitting position:

As required. Max. length 6.000 mm without joints.

Carriage mounting:

By T-slots.

Unit mounting:

By T-slots and mounting sets. The linear axis can be combined with any T-slot profile.

Belt performance:

HTD with steel reinforcement, no backlash when changing direction, repeatability $\pm 0,1$ mm.

Carriage support:

In the standard version, the carriage runs on two runner blocks which can be adjusted and serviced at a central servicing position. For longer carriages the number of runner blocks can be increased.

7.1

Forces and torques	Size	60		80		100		125	
	permitted dyn. forces*	5000 km	10000 km	5000 km	10000 km	5000 km	10000 km	5000 km	10000 km
F_x (N)		894	800	1900	1800	4000	3800	5900	5750
F_y (N)		1410	990	3570	2550	4080	2900	6892	5470
F_z (N)		3520	2500	8500	6050	10300	7270	17205	13659
M_x (Nm)		33	23	107	75	142	101	288	228
M_y (Nm)		104	73	310	222	439	311	1110	881
M_z (Nm)		100	70	296	210	412	292	1012	803
All forces and torques related to the following:									
existing values $\frac{F_y}{F_{y_{dyn}}} + \frac{F_z}{F_{z_{dyn}}} + \frac{M_x}{M_{x_{dyn}}} + \frac{M_y}{M_{y_{dyn}}} + \frac{M_z}{M_{z_{dyn}}} \leq 1$									
table values $\frac{F_y}{F_{y_{dyn}}} + \frac{F_z}{F_{z_{dyn}}} + \frac{M_x}{M_{x_{dyn}}} + \frac{M_y}{M_{y_{dyn}}} + \frac{M_z}{M_{z_{dyn}}} \leq 1$									
No-load torque									
Nm		1,0		1,4		1,8			
Speed									
(m/s) max		5		5		5		5	
Tensile force									
permanent (N)		900		1900		4000		5900	
0,2 s (N)		1000		2090		4300		6350	
Geometrical moments of inertia of aluminium profile									
I_x mm ⁴		4,3x10 ⁵		14,3x10 ⁵		31,8x10 ⁵		74,9x10 ⁵	
I_y mm ⁴		5,8x10 ⁵		18,7x10 ⁵		46,5x10 ⁵		106,5x10 ⁵	
Elastic modulus N/mm ²		70000		70000		70000		70000	

For life-time calculation use our homepage.

* referred to lifetime

Driving torque:

$$M_o = \frac{F \cdot P \cdot S_i}{2000 \cdot \pi} + M_n$$

$$P_o = \frac{M_o \cdot n}{9550}$$

F = force (N)
 P = pulley action perimeter (mm)
 S_i = safety factor 1,2 ... 2
 M_n = no-load torque (Nm)
 n = rpm pulley (min⁻¹)
 M_o = driving torque (Nm)
 P_o = motor power (KW)

Deflection:

$$f = \frac{F \cdot L^3}{E \cdot I \cdot 192}$$

f = deflection (mm)
 F = load (N)
 L = free length (mm)
 E = elastic modulus 70000 (N/mm²)
 I = second moment of area (mm⁴)

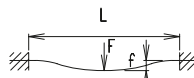

Linear system QSZ 60, 80, 100, 125

Dimensions (mm)

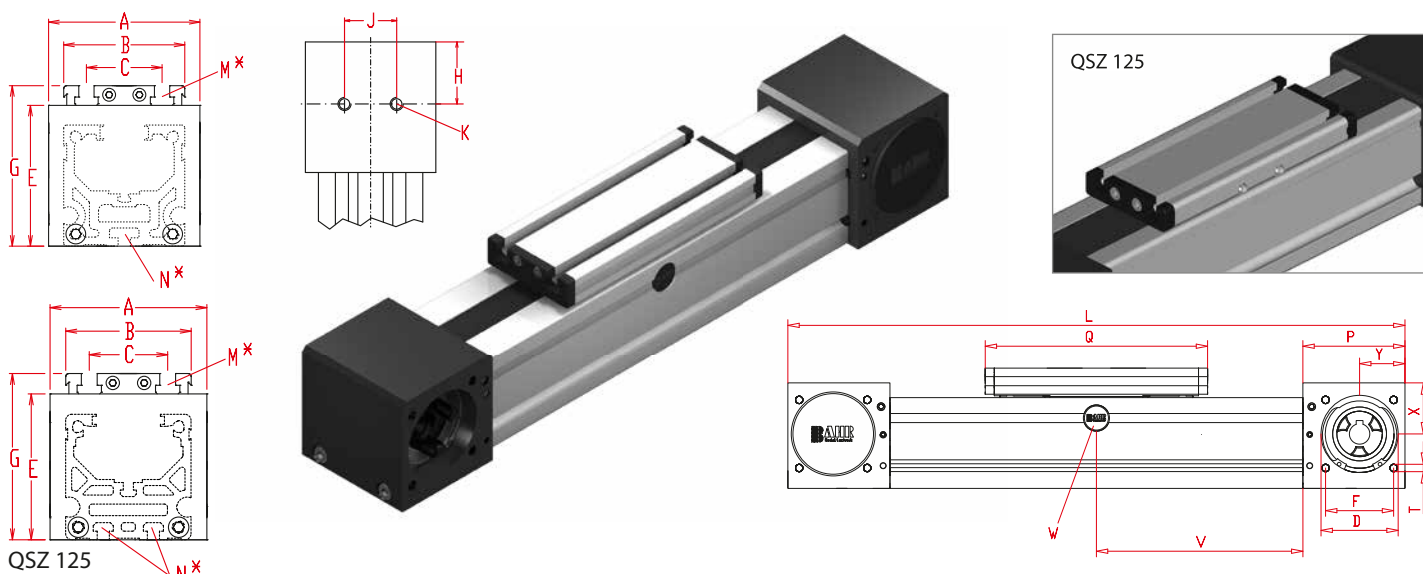

*For slide nuts refer to chapter 2.2 page 2

Increasing the carriage length will increase the basic length by the same amount.

Size	Basic length L	A	B	C	D -0,05	E	F	G	H	J	K	N for	M for	P	Q	T	X	Y	Basic weight	Weight per 100 mm
QSZ 60	300	80	60	36	47	63	42	79	29,5	30	M 8	M 5	M 6	59	177	M 6	27	26	3,5 kg	0,55 kg
QSZ 80	430	100	80	50	68	93	60	106	47,5	40	M 10	M 6	M 8	90	232	M 8	45	40	10,4 kg	0,96 kg
QSZ 100	510	130	100	66	90	110	80	129	55	50	M 12	M 10	M 10	110	268	M 10	49	50	15,9 kg	1,47 kg
QSZ 125	570	160	125	82	110	134,5	100	157,5	65	60	M 12	M 10	M 12	130	300	M 10	60	60	30,5 kg	2,21 kg

V = Q + 100 mm

W = servicing position

0 Choice of guide body profile:

- (0) Standard (1) corrosion-protected screws
- (4) expanded corrosion-protected version (depending on the availability of components)

0 Choice of carriages:

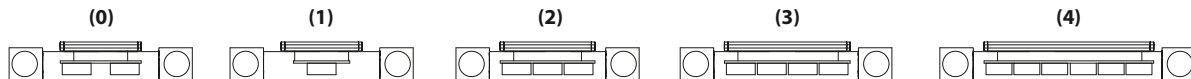

Size	Version 0		Version 1		Version 2		Version 3		Version 4	
	Q	L	Q	L	Q	L	Q	L	Q	L
60	177	300	152	280	242	370	302	430		
80	232	430	196	390	312	510	390	585		
100	268	510	260	500	362	610	448	690	628	860
125	300	570	260	530	365	635	467	740		

0 Drive version:

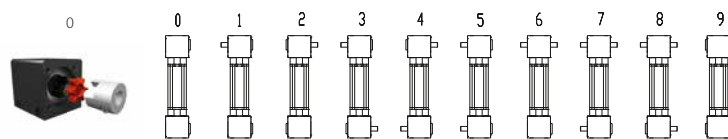

Size	Shaft ø h6 x length	Key
60	14 x 35	5x5x28
80	18 x 45	6x6x40
100	22 x 45	6x6x40
125	30 x 55	8x7x50

9 is as 0, but with coupling claws on both sides. The standard version is supplied without shaft. A shaft can be retrofitted by inserting it into the pulley bore and securing it with 2 locking rings or clamping sets (Size 100 + 125).

Belt table / Coupling claw:

Code No.	Size	Belt	Pulley		Coupling
			mm/rev.	Number of teeth	
0 3	60	5M25	130	26	14
0 4	80	8M30	176	22	19
0 7	100	8M50	224	28	24
0 9	125	8M70	288	36	28

QSZ 80 1 0 0 0 0 4 1 1500 — Basic length + stroke = total length

Pos. 1 2 3 4 5 6 7

Sample ordering code:

QSZ80 with standard body profile, standard carriage, coupling claw on one side, 1070 mm stroke

For additional accessories refer to chapter 2.2

