

Positioning system ELZZ 60, 60S, 80, 80S, 100, 125

Belt drive with two separately driven carriages

Specifications

3.1



Function:

Same functions as ELZ, but each carriage can be moved separately by its own drive. This unit has twin pulleys, which run on separate bearings, and two independent, parallel drive belts, one for each carriage.

Fitting position: As required. Max. length 4.000 mm without joints.

Carriage mounting: By T-slots.

Unit mounting: By T-slots or tapped holes in the bearing block, mounting sets.

Belt type: HTD with steel reinforcement, no backlash when changing direction, repeatability $\pm 0,1$ mm.

Forces and torques	Size	ELZZ 60		ELZZ 60 S		ELZZ 80		ELZZ 80 S		ELZZ 100		ELZZ 125	
	Forces/Torques	static	dynamic	static	dynamic	static	dynamic	static	dynamic	static	dynamic	static	dynamic
F_x (N)	298	250	298	250	679	500	679	500	1210	1100	1900	1800	
F_y (N)	3000	2000	4100	3100	3000	2000	4600	3600	8000	6500	12000	9000	
F_z (N)	1700	1100	2160	1600	1700	1100	3000	2600	3600	2200	6000	4500	
M_x (Nm)	67	43	88	65	90	55	170	140	300	230	600	450	
M_y (Nm)	90	70	190	140	110	80	270	230	400	270	750	600	
M_z (Nm)	120	100	230	170	150	120	300	220	750	500	1350	1150	
All forces and torques relate to the following:													
existing values $\frac{F_y}{F_{y_{dyn}}} + \frac{F_z}{F_{z_{dyn}}} + \frac{M_x}{M_{x_{dyn}}} + \frac{M_y}{M_{y_{dyn}}} + \frac{M_z}{M_{z_{dyn}}} \leq 1$													
table values $\frac{F_y}{F_{y_{dyn}}} + \frac{F_z}{F_{z_{dyn}}} + \frac{M_x}{M_{x_{dyn}}} + \frac{M_y}{M_{y_{dyn}}} + \frac{M_z}{M_{z_{dyn}}} \leq 1$													
No-load torque													
Nm		0,6		0,7		0,9		1,2		1,4		1,8	
Speed													
(m/s) max		5		5		6		8		10		10	
Tensile force													
permanent (N)		298		298		679		679		1210		1900	
0,2 s (N)		333		333		746		746		1331		2090	
Geometrical moments of inertia of aluminium profile													
I_x mm ⁴		$6,79 \times 10^5$		$6,79 \times 10^5$		$18,99 \times 10^5$		$18,99 \times 10^5$		$44,4 \times 10^5$		$101,5 \times 10^5$	
I_y mm ⁴		$6,97 \times 10^5$		$6,97 \times 10^5$		$18,97 \times 10^5$		$18,97 \times 10^5$		$44,8 \times 10^5$		$101,5 \times 10^5$	
E-Modulus N/mm ²		70000		70000		70000		70000		70000		70000	

For life-time calculation of rollers use our homepage.

Driving torque:

$$M_o = \frac{F \cdot P \cdot S_i}{2000 \cdot \pi} + M_n$$

$$P_o = \frac{M_o \cdot n}{9550}$$

F = force (N)
 P = pulley action perimeter (mm)
 S_i = safety factor 1,2 ... 2
 M_n = no-load torque (Nm)
 n = rpm pulley (min⁻¹)
 M_o = driving torque (Nm)
 P_o = motor power (KW)

Deflection:

$$f = \frac{F \cdot L^3}{E \cdot I \cdot 192}$$

f = deflection (mm)
 F = load (N)
 L = free length (mm)
 E = elastic modulus 70000 (N/mm²)
 I = second moment of area (mm⁴)

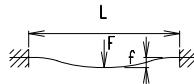

Positioning system ELZZ 60, 60S, 80, 80S, 100, 125

Dimensions (mm)

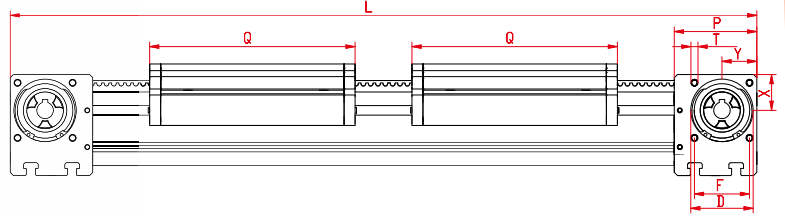
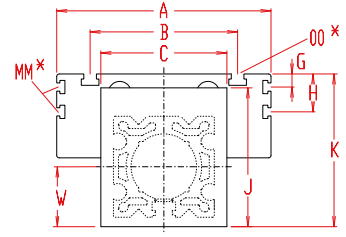
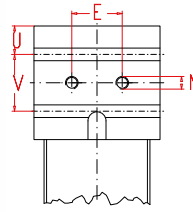
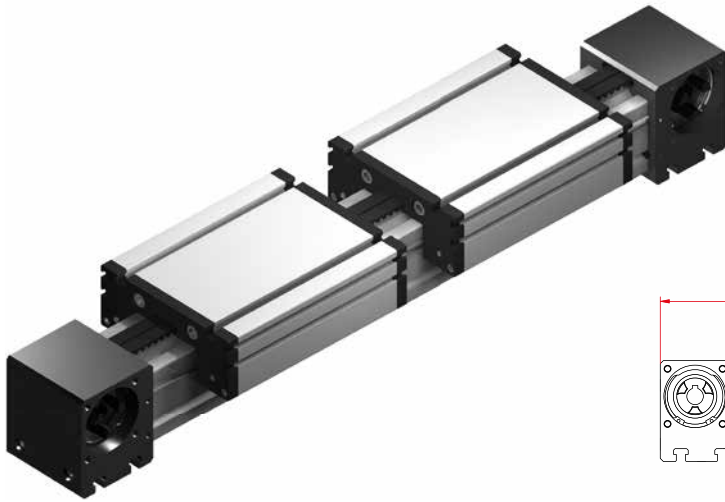

3.1

*For slide nuts refer to chapter 2.2 page 2

Increasing the carriage length will increase the basic length by the same amount.

Size □	Basic length L	A	B	C	D -0,05	E	F	G	H	J	K	MM for	N	OO for	P	Q	T	U	V	W	X	Y	Basic weight	Weight per 100 mm
ELZZ 60	460	144	96	80	47	30	42	-	-	82	90	-	M 8	M 8	59	168	M 6	15	30	41	27	26	7,4 kg	0,62 kg
ELZZ 60S	510	170	108	80	47	30	42	-	-	82	94	-	M 8	M 8	59	194	M 6	15	30	41	27	26	9,4 kg	0,62 kg
ELZZ 80	570	170	117	100	68	40	60	10,5	30,5	110	121	M 6	M 10	M 10	90	194	M 8	22,5	45	51	39	38	12,8 kg	1,00 kg
ELZZ 80S	610	190	126	100	68	40	60	12,5	30	110	122	M 6	M 10	M 8	90	214	M 8	22,5	45	51	39	38	14,8 kg	1,00 kg
ELZZ 100	830	230	155	130	90	50	80	-	29	135	154	M 10	M 12	M 10	110	300	M 10	23	64	65	50	50	33,0 kg	1,60 kg
ELZZ 125	990	295	200	160	110	60	100	-	30	167	191	M 10	M 12	M 12	130	365	M 10	38	50	82	60	60	52,0 kg	2,10 kg

0 Choice of guide body profile:

(0) Standard (2) corrosion-protected guide rods and screws

0 Choice of carriages:

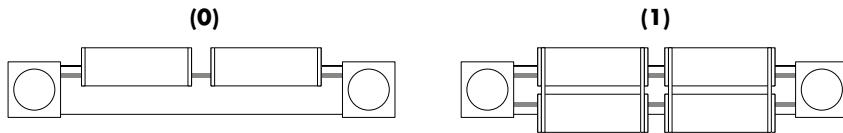

Size	Version 1	
	Q	L
60	184	492
60S	214	550
80	210	602
80S	234	650
100	316	862
125	389	1038

0 Drive version:



The standard version is supplied without shaft.

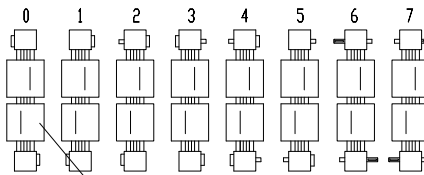

connected with the left belt

- Coupling claw on one side
- Standard-shaft¹
- Shaft one size smaller²

Belt table

Code No.	Size	Belt	mm/rev.	Number of teeth
0 2	60 (S)	5M09	130	26
0 5	80 (S)	8M12	192	24
0 6	100	8M20	256	32
0 7	125	8M30	304	38

Shaft dimensions / Coupling claw

Size	Shaft ø h6 x length	Key	Coupling
60 (S) ¹	14 x 35	5x5x30	14
60 (S) ²	10 x 27	3x3x25	14
80 (S) ¹	18 x 45	6x6x40	19
80 (S) ²	14 x 35	5x5x28	19
100 ¹	22 x 45	6x6x40	24
100 ²	18 x 45	6x6x40	24
125 ¹	30 x 55	8x7x50	28
125 ²	22 x 45	6x6x40	28

ELZZ 60 4 0 0 0 0 2 1 01500

Basic length + stroke = total length

For combination kits and connecting elements refer to chapter 2.2

Pos. 1 2 3 4 5 6 7

Sample ordering code:

ELZZ 60 with standard body profile, standard carriage and coupling claw on one side, 1040 mm stroke

