





Linear system **ELZQ 60, 80, 80S**

RACK AND PINION DRIVE

-  HIGH LOAD CAPACITY
-  HIGH RIGIDITY
-  LIFTING SYSTEM
-  HIGH OPERATIONAL RELIABILITY

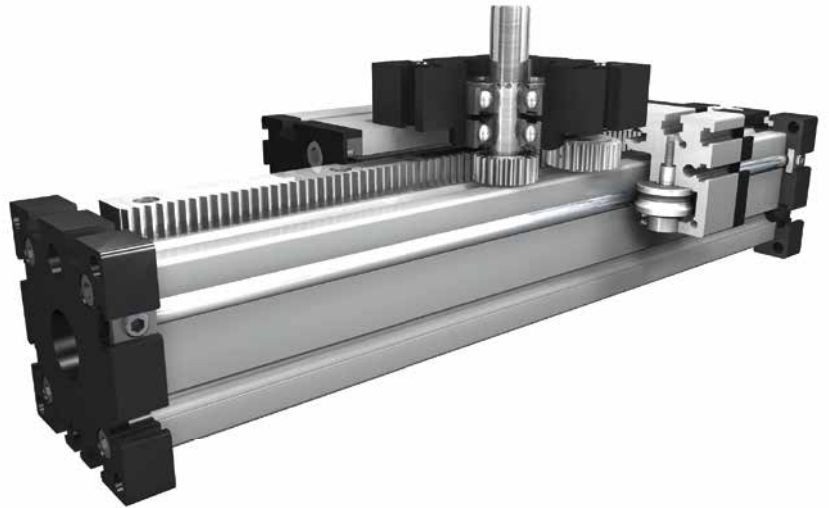

4.1

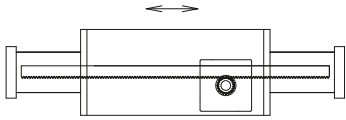

Function:

This unit consists of an aluminium square profile with integrated, hardened steel guide rods. The carriage, which has internal linear ball bearings that can be adjusted free of play, is driven along the guide rods by a high precision rack. The rack and pinion system is suitable for highly dynamic servo operation and ideal for lifting movements. The pinion has maintenance-free ball bearings. The rack is lubricated by a toothed felt wheel.

Fitting position:

As required. Max. length without joints 6.000 mm.

Carriage mounting:

By T-slots.

Unit mounting:

By T-slots and holes in the bearing block, mounting sets.

Rack:

Cf53, h7 = finely toothed, h6 (hardened and ground, finely toothed). Repeatability: $\pm 0,1$ mm.

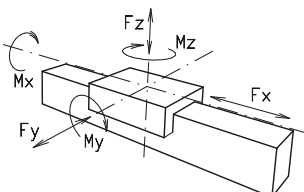
Forces and torques	Size	ELZQ 60 h6		ELZQ 60 h7		ELZQ 80 h6		ELZQ 80 h7		ELZQ 80S h6		ELZQ 80S h7	
	Forces/Torques	static	dynamic	static	dynamic	static	dynamic	static	dynamic	static	dynamic	static	dynamic
	F_x (N)	1800	1400	940	780	1800	1400	940	780	1800	1400	940	780
	F_y (N)	3000	2000	3000	2000	3000	2000	3000	2000	4600	3600	4600	3600
	F_z (N)	1700	1100	1700	1100	1700	1100	1700	1100	3000	1800	3000	1800
	M_x (Nm)	67	43	67	43	90	55	90	55	170	140	170	140
	M_y (Nm)	90	70	90	70	110	80	110	80	270	230	270	230
	M_z (Nm)	120	100	120	100	150	120	150	120	300	220	300	220
All forces and torques related to the following:													
existing values $\frac{F_y}{F_{y_{dyn}}} + \frac{F_z}{F_{z_{dyn}}} + \frac{M_x}{M_{x_{dyn}}} + \frac{M_y}{M_{y_{dyn}}} + \frac{M_z}{M_{z_{dyn}}} \leq 1$													
table values													
No-load torque													
Nm		0,6		0,6		1,0		1,0		1,5		1,5	
Speed													
(m/s) max		4		4		4		4		4		4	
Geometrical moments of inertia of aluminium profile													
I_{xx} mm ⁴		6,79x10 ⁵		6,79x10 ⁵		18,99x10 ⁵		18,99x10 ⁵		18,99x10 ⁵		18,99x10 ⁵	
I_{yy} mm ⁴		6,97x10 ⁵		6,97x10 ⁵		18,97x10 ⁵		18,97x10 ⁵		18,97x10 ⁵		18,97x10 ⁵	
E-Modulus N/mm ²		70000		70000		70000		70000		70000		70000	

For life-time calculation of rollers use our homepage.

Driving torque:

$$M_o = \frac{F \cdot P \cdot S_i}{2000 \cdot \pi} + M_n$$

$$P_o = \frac{M_o \cdot n}{9550}$$

F = force (N)
 P = pulley action perimeter (mm)
 S_i = safety factor 1,2 ... 2
 M_n = no-load torque (Nm)
 n = rpm pulley (min⁻¹)
 M_o = driving torque (Nm)
 P_o = motor power (KW)

Deflection:

$$f = \frac{F \cdot L^3}{E \cdot I \cdot 192}$$

f = deflection (mm)
 F = load (N)
 L = free length (mm)
 E = elastic modulus 70000 (N/mm²)
 I = second moment of area (mm⁴)

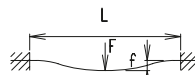

Linear system **ELZQ 60, 80, 80S**

Dimensions (mm)

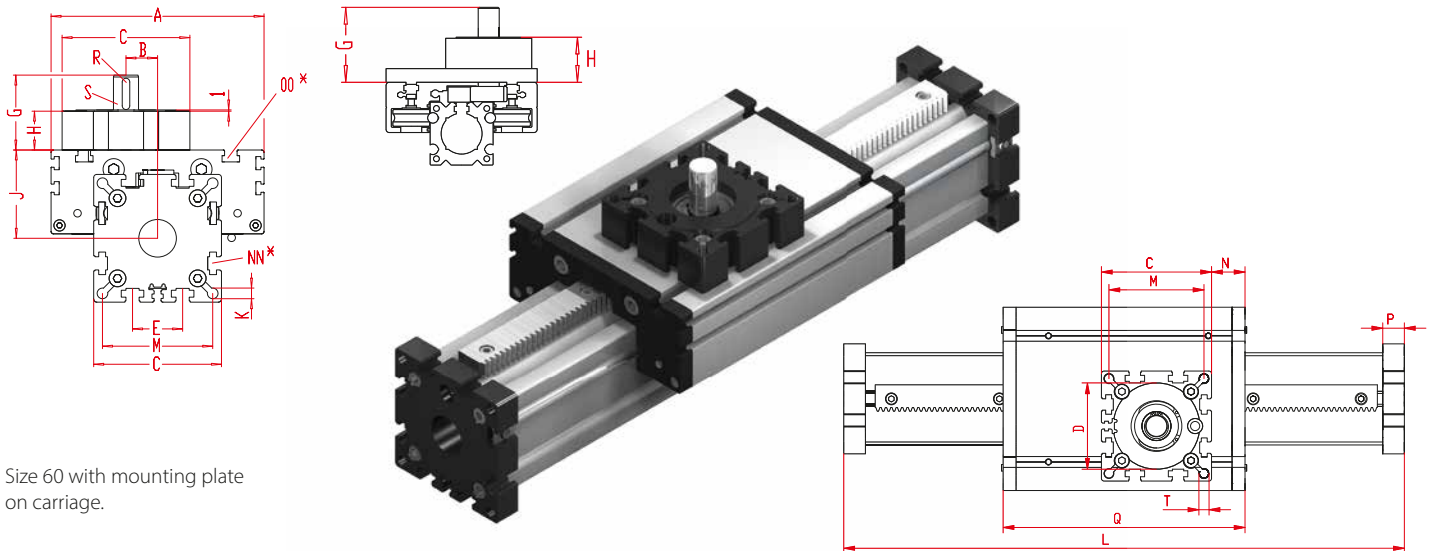

4.1

Size 60 with mounting plate on carriage.

*For slide nuts refer to chapter 2.2 page 2

Increasing the carriage length will increase the basic length by the same amount.

Size	Basic length L	A	B	C	D Ø ±0,05	E	G	H	J	K	M	N	NN for	OO for	P	Q	T	Basic weight	Weight per 100 mm
ELZQ 60	230	144	25,5	82	62	30	71,5	42	49	8,5	69	19	M 8	M 8	16	194	M 10	5,0 kg	0,68 kg
ELZQ 80	260	170	25,5	102	80	40	60,5	31	70	8,5	88	25	M 10	M 10	20	214	M 10	11,0 kg	1,19 kg
ELZQ 80S	280	190	25,5	102	80	40	60,5	31	71	8,5	88	13	M 10	M 8	20	234	M 10	12,0 Kg	1,19 kg

0 Choice of guide body profile:

- (0) Standard
- (2) corrosion-protected guide rods and screws
- (4) expanded corrosion-protected version (depending on the availability of components)

0 Choice of carriages:

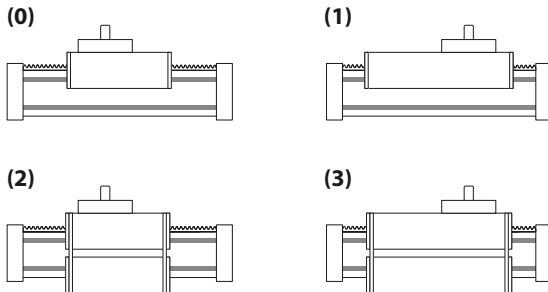

Size	Version 1		Version 2		Version 3	
	Q	L	Q	L	Q	L
60	338	374	210	246	354	390
80	384	430	230	276	400	446
80S	404	450	254	300	420	466

1 Drive version:

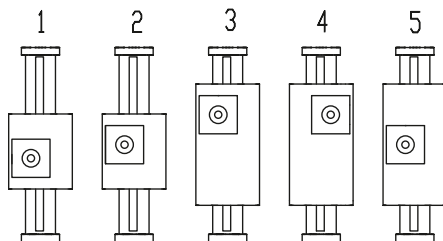

Size	Shaft Ø h6 x length	Key	Pinion	
			mm/rev.	Modul
60	20 x 29,5	6x6x25	100	1,6
80 (S)	20 x 29,5	6x6x25	100	1,6

0 Rack and pinion accuracy:

- (0) h7 (standard)
- (1) h6 (hardened and ground, finely toothed)

ELZQ 60 0 0 0 1 0 2 0 1500

Pos. 1 2 3 4 5 6 7

Basic length + stroke = total length

For combination kits and connecting elements refer to chapter 2.2

Sample ordering code:

ELZQ 60 with standard body profile, standard carriage, position of drive 1, rack and pinion accuracy class h7, 1270 mm stroke

