

Positioning system ELSD 40, 60, 60S, 80, 80S, 100

Belt drive with rotary shaft

Specifications

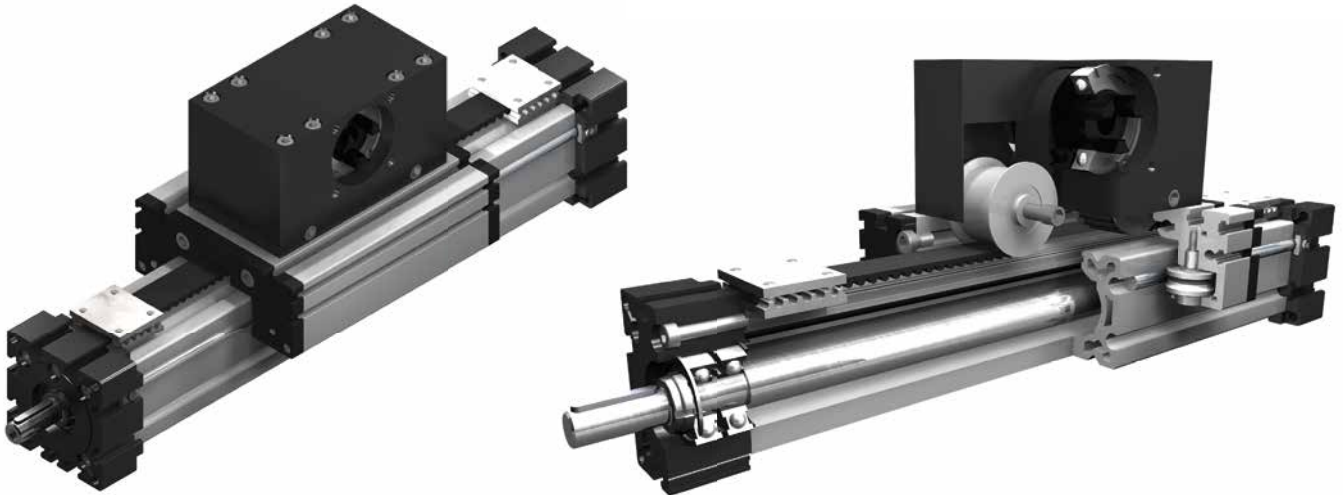

Function:

Same as ELSZ, but with an additional rotary shaft, fitted within the aluminium body. One end can be driven by any suitable motor, and the other end is provided with a shaft with feather key and an axial tapped hole for fitting grippers or other components.

Fitting position: As required. Max. length 2.000 mm.

Carriage mounting: By T-slots.

Unit mounting: By T-slots or tapped holes in the bearing blocks, mounting sets.

Belt type: HTD with steel reinforcement, no backlash when changing direction, repeatability $\pm 0,1$ mm.

Forces and torques	Size	ELSD 40		ELSD 60		ELSD 60 S		ELSD 80		ELSD 80 S		ELSD 100	
	Forces/Torques	static	dynamic	static	dynamic	static	dynamic	static	dynamic	static	dynamic	static	dynamic
F_x (N)		390	350	894	800	894	800	1900	1800	1900	1800	4000	3800
F_y (N)		1200	700	3000	2000	4100	3100	3000	2000	4600	3600	8000	6500
F_z (N)		900	650	1700	1100	2160	1600	1700	1100	3000	1800	3600	2200
F_p (N)		50		150		150		250		250		400	
M_x (Nm)		25	20	67	43	88	65	90	55	170	140	300	230
M_y (Nm)		32	18	90	70	190	140	110	80	270	230	400	270
M_z (Nm)		35	25	120	100	230	170	150	120	300	220	750	500
M_b (Nm)		5		10		10		20		20		30	
All forces and torques relate to the following:													
existing values		$\frac{F_y}{F_{y_{dyn}}} + \frac{F_z}{F_{z_{dyn}}} + \frac{M_x}{M_{x_{dyn}}} + \frac{M_y}{M_{y_{dyn}}} + \frac{M_z}{M_{z_{dyn}}} \leq 1$											
table values													
No-load torque													
Nm		0,7		0,9		0,9		1,1		1,2		1,5	
Stiction torque M_b (Nm)		0,2		0,4		0,5		0,6		0,7		0,8	
Speed													
[m/s] max		4		5		7		6		8		8	
Tensile force													
permanent (N)		390		900		900		1900		1900		4000	
0,2 s (N)		480		1000		1000		2090		2090		4300	
Geometrical moments of inertia of aluminium profile													
I_x mm ⁴		1,32x10 ⁵		6,79x10 ⁵		6,79x10 ⁵		18,99x10 ⁵		18,99x10 ⁵		44,4x10 ⁵	
I_y mm ⁴		1,34x10 ⁵		6,97x10 ⁵		6,97x10 ⁵		18,97x10 ⁵		18,97x10 ⁵		44,8x10 ⁵	
E-Modulus N/mm ²		70000		70000		70000		70000		70000		70000	

For life-time calculation of rollers use our homepage.

Driving torque:

$$M_o = \frac{F \cdot P \cdot S_i}{2000 \cdot \pi} + M_n$$

$$P_o = \frac{M_o \cdot n}{9550}$$

F = force (N)
 P = pulley action perimeter (mm)
 S_i = safety factor 1,2 ... 2
 M_n = no-load torque (Nm)
 n = rpm pulley (min⁻¹)
 M_o = driving torque (Nm)
 P_o = motor power (KW)

Deflection:

$$f = \frac{F \cdot L^3}{E \cdot I \cdot 192}$$

f = deflection (mm)
 F = load (N)
 L = free length (mm)
 E = elastic modulus 70000 (N/mm²)
 I = second moment of area (mm⁴)

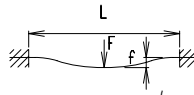

Positioning system ELSD 40, 60, 60S, 80, 80S, 100

Dimensions (mm)

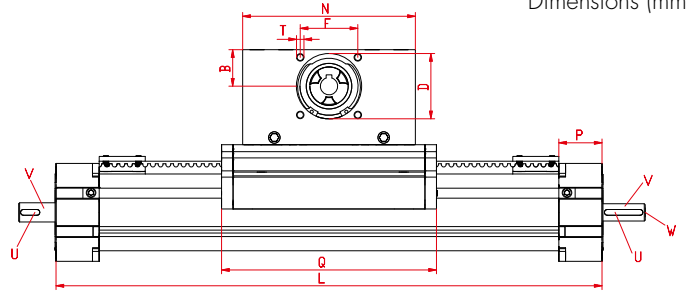
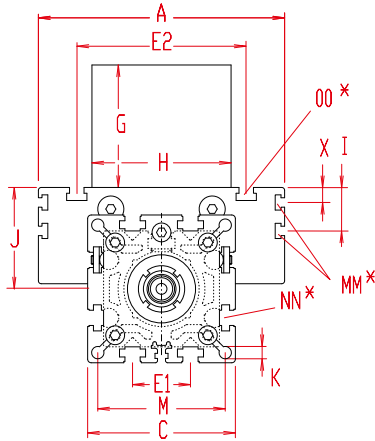

Size	Shaft (drive end)		Shaft (load end)		
	Shaft ø h6 x length (V)	Key (U)	Shaft ø h6 x length (V)	Key (U)	Thread (W)
40	10 x 20	3x3x10	12 x 20	4x4x10	M 6 x 12
60 (S)	14 x 25	5x5x20	17 x 25	5x5x20	M 8 x 20
80 (S)	18 x 30	6x6x20	20 x 30	6x6x20	M 10 x 20
100	22 x 35	6x6x30	25 x 35	8x7x30	M 12 x 25

Increasing the carriage length will increase the basic length by the same amount.

*For slide nuts refer to chapter 2.2 page 2

Size	Basic length L	A	B	C	D -0,05	E1	E2	F	G	H	I	J	K	M	MM for	N	NN for	OO for	P	Q	T	X	Basic weight	Weight per 100 mm
ELSD 40	260	100	20	58	37	25	66	32	65	60	-	35	6,5	47	-	110	M 6	M 6	25	142	M 5	-	2,4 kg	0,40 kg
ELSD 60	320	144	30	82	47	30	96	42	80	80	-	49	8,5	69	-	130	M 8	M 8	35	168	M 6	-	5,9 kg	0,87 kg
ELSD 60S	345	170	30	82	47	30	108	42	80	80	-	53	8,5	69	-	130	M 8	M 8	35	194	M 6	-	6,9 kg	0,87 kg
ELSD 80	415	170	39	102	68	40	117	60	100	100	30,5	70	8,5	88	M 6	180	M 10	M 10	45	214	M 8	10,5	12,5 kg	1,30 kg
ELSD 80S	415	190	39	102	68	40	126	60	100	100	30	71	8,5	88	M 6	180	M 10	M 8	45	214	M 8	12,5	14,0 kg	1,30 kg
ELSD 100	585	230	60	130	90	50	155	80	130	130	29	89	10,5	112	M10	270	M 10	M 10	55	310	M 10	-	27,0 kg	1,70 kg

0 Choice of guide body profile:

- (0) Standard
- (2) corrosion-protected guide rods and screws
- (4) expanded corrosion-protected version (depending on the availability of components)

0 Choice of carriages:

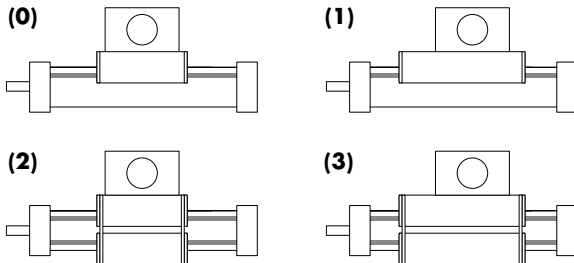

Size	Version 1		Version 2		Version 3	
	Q	L	Q	L	Q	L
40	237	355	160	276	253	371
60	303	453	184	336	319	469
60S	329	469	214	365	349	489
80	379	575	230	431	395	591
80S	399	595	245	450	419	615
100	535	810	326	601	551	826

0 Drive version:

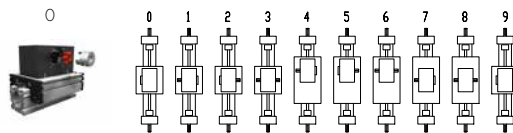

The standard version is supplied without shaft. A shaft can be retrofitted by inserting it into the pulley bore and securing it with 2 locking rings or tension sets (size 100).

Version 9 is the same as 0, but with double sided coupling claw.

Belt table

Code No.	Size	Belt	mm/rev.	Number of teeth
0 3	40	5M15	100	20
0 4	60 (S)	5M25	130	26
0 7	80 (S)	8M30	192	24
0 9	100	8M50	256	32

Shaft dimensions / Coupling claw

Size	Shaft ø h6 x length	Key	Coupling
40	10 x 27	3x3x25	9
60 (S)	14 x 35	5x5x28	14
80 (S)	18 x 45	6x6x40	19
100	22 x 45	6x6x40	24

ELSD 60 0 0 0 0 0 4 1 01500 Basic length + stroke = total length

Pos. 1 2 3 4 5 6 7

Sample ordering code:

ELSD 60 with standard body profile, standard carriage and coupling claw on one side, 1180 mm stroke

For combination kits and connecting elements refer to chapter 2.2

Positioning system ELSD 40, 60, 60S, 80, 80S, 100

Belt drive with widened belt and rotary shaft

Specifications

3.1

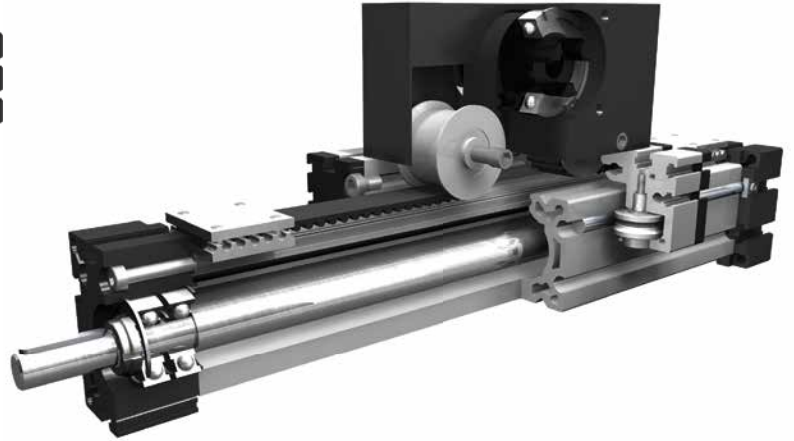
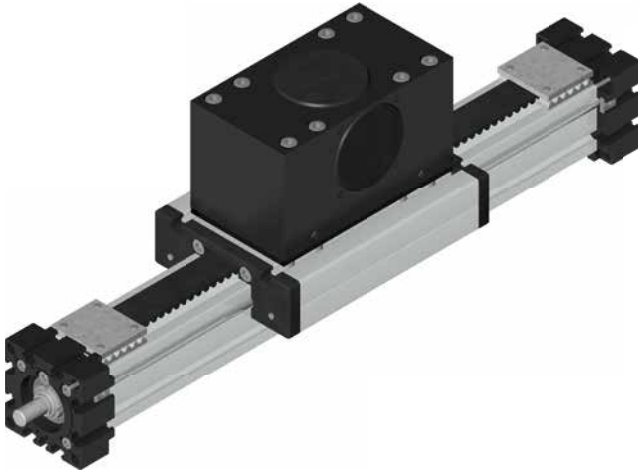

Function:

Same as ELSZ, but with an additional rotary shaft, fitted within the aluminium body. One end can be driven by any suitable motor, and the other end is provided with a shaft with feather key and an axial tapped hole for fitting grippers or other components.

Fitting position: As required. Max. length 2.000 mm.

Carriage mounting: By T-slots.

Unit mounting: By T-slots or tapped holes in the bearing blocks, mounting sets.

Belt type: HTD with steel reinforcement, no backlash when changing direction, repeatability ± 0,1 mm.

Forces and torques	Size	ELSD 40		ELSD 60		ELSD 60 S		ELSD 80		ELSD 80 S		ELSD 100	
	Forces/Torques	static	dynamic	static	dynamic	static	dynamic	static	dynamic	static	dynamic	static	dynamic
F_x (N)		894	800	1900	1800	1900	1800	4000	3800	4000	3800	5900	5750
F_y (N)		1200	700	3000	2000	4100	3100	3000	2000	4600	3600	8000	6500
F_z (N)		900	650	1700	1100	2160	1600	1700	1100	3000	1800	3600	2200
F_D (N)		50		150		150		250		250		400	
M_x (Nm)		25	20	67	43	88	65	90	55	170	140	300	230
M_y (Nm)		32	18	90	70	190	140	110	80	270	230	400	270
M_z (Nm)		35	25	120	100	230	170	150	120	300	220	750	500
M_b (Nm)		5		10		10		20		20		30	
All forces and torques relate to the following:													
existing values $\frac{F_y}{F_{y_{dyn}}} + \frac{F_z}{F_{z_{dyn}}} + \frac{M_x}{M_{x_{dyn}}} + \frac{M_y}{M_{y_{dyn}}} + \frac{M_z}{M_{z_{dyn}}} \leq 1$													
table values $\frac{F_y}{F_{y_{dyn}}} + \frac{F_z}{F_{z_{dyn}}} + \frac{M_x}{M_{x_{dyn}}} + \frac{M_y}{M_{y_{dyn}}} + \frac{M_z}{M_{z_{dyn}}} \leq 1$													
No-load torque													
Nm		0,7		0,9		0,9		1,1		1,2		1,5	
Stiction torque M_b (Nm)		0,2		0,4		0,5		0,6		0,7		0,8	
Speed													
(m/s) max		4		5		7		6		8		8	
Tensile force													
permanent (N)		900		1900		1900		4000		4000		5900	
0,2 s (N)		1000		2090		2090		4300		4300		6350	
Geometrical moments of inertia of aluminium profile													
I_x mm ⁴		1,32x10 ⁵		6,79x10 ⁵		6,79x10 ⁵		18,99x10 ⁵		18,99x10 ⁵		44,4x10 ⁵	
I_y mm ⁴		1,34x10 ⁵		6,97x10 ⁵		6,97x10 ⁵		18,97x10 ⁵		18,97x10 ⁵		44,8x10 ⁵	
E-Modulus N/mm ²		70000		70000		70000		70000		70000		70000	

For life-time calculation of rollers use our homepage.

Driving torque:

$$M_o = \frac{F \cdot P \cdot S_i}{2000 \cdot \pi} + M_n$$

$$P_o = \frac{M_o \cdot n}{9550}$$

- F = force (N)
- P = pulley action perimeter (mm)
- S_i = safety factor 1,2 ... 2
- M_n = no-load torque (Nm)
- n = rpm pulley (min⁻¹)
- M_o = driving torque (Nm)
- P_o = motor power (KW)

Deflection:

$$f = \frac{F \cdot L^3}{E \cdot I \cdot 192}$$

- f = deflection (mm)
- F = load (N)
- L = free length (mm)
- E = elastic modulus 70000 (N/mm²)
- I = second moment of area (mm⁴)

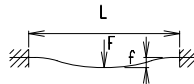

Positioning system ELSD 40, 60, 60S, 80, 80S, 100

Dimensions (mm)

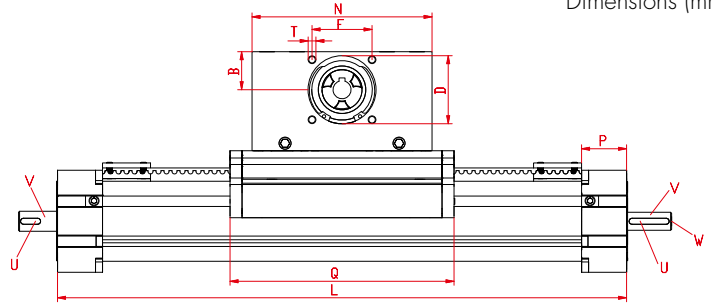
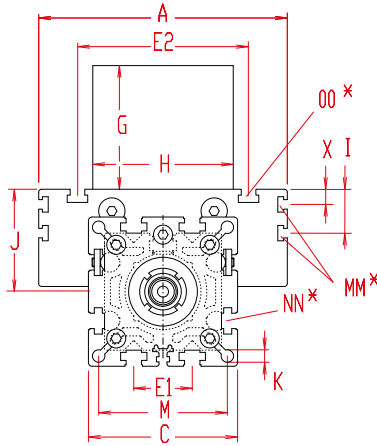

Size	Shaft (drive end)		Shaft (load end)		
	Shaft ø h6 x length (V)	Key (U)	Shaft ø h6 x length (V)	Key (U)	Thread (W)
40	10 x 20	3x3x10	12 x 20	4x4x10	M 6 x 12
60 (S)	14 x 25	5x5x20	17 x 25	5x5x20	M 8 x 20
80 (S)	18 x 30	6x6x20	20 x 30	6x6x20	M 10 x 20
100	22 x 35	6x6x30	25 x 35	8x7x30	M 12 x 25

Increasing the carriage length will increase the basic length by the same amount.

*For slide-nuts refer to chapter 2.2 page 2

Size	Basic length L	A	B	C	D -0,05	E1	E2	F	G	H	I	J	K	M	MM for	N	NN for	OO for	P	Q	T	X	Basic weight	Weight per 100 mm
ELSD 40	286	100	30	58	47	25	66	42	83	80	-	35	6,5	47	-	130	M 6	M 6	25	164	M 6	-	2,7 kg	0,40 kg
ELSD 60	395	144	39	82	68	30	96	60	105	100	-	49	8,5	69	-	180	M 8	M 8	35	214	M 8	-	6,5 kg	0,87 kg
ELSD 60S	395	170	39	82	68	30	108	60	105	100	-	53	8,5	69	-	180	M 8	M 8	35	214	M 8	-	7,5 kg	0,87 kg
ELSD 80	510	170	60	102	90	40	117	80	140	130	30,5	70	8,5	88	M 6	270	M 10	M 10	45	304	M 10	10,5	13,7 kg	1,30 kg
ELSD 80S	510	190	60	102	90	40	126	80	140	130	30	71	8,5	88	M 6	270	M 10	M 8	45	304	M 10	12,5	15,2 kg	1,30 kg
ELSD 100	625	230	62	130	110	50	155	100	143	160	29	89	10,5	112	M10	310	M 10	M 10	55	350	M 10	-	33,4 kg	1,70 kg

0 Choice of guide body profile:

- (0) Standard
- (2) corrosion-protected guide rods and screws
- (4) expanded corrosion-protected version (depending on the availability of components)

0 Choice of carriages:

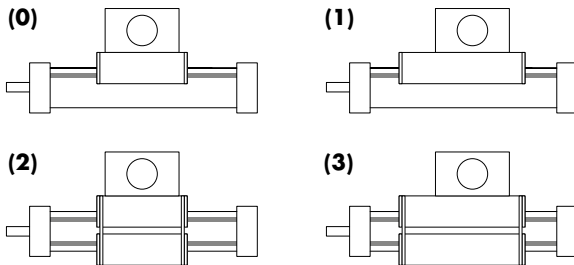

Size	Version 1		Version 2		Version 3	
	Q	L	Q	L	Q	L
40	257	381	180	302	273	397
60	353	534	230	411	369	550
60S	379	560	234	415	399	580
80	469	675	320	526	485	691
80S	489	695	324	530	509	715
100	575	850	366	641	591	866

0 Drive version:

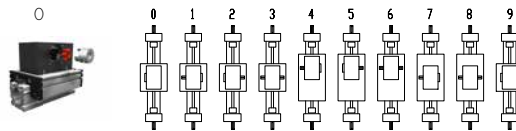

The standard version is supplied without shaft. A shaft can be retrofitted by inserting it into the pulley bore and securing it with 2 locking rings or tension sets (size 80 + 100).

Version 9 is the same as 0, but with double sided coupling claw.

Belt table

Code No.	Size	Belt	mm/rev.	Number of teeth
0 4	40	5M25	130	26
0 7	60 (S)	8M30	192	24
0 9	80 (S)	8M50	256	32
1 0	100	8M70	304	38

Shaft dimensions / Coupling claw

Size	Shaft ø h6 x length	Key	Coupling
40	14 x 35	5x5x28	14
60 (S)	18 x 45	6x6x40	19
80 (S)	22 x 45	6x6x40	24
100	30 x 55	8x7x40	28

ELSD 60 0 0 0 0 0 7 1 01500

Basic length + stroke = total length

Pos. 1 2 3 4 5 6 7

Sample ordering code:

ELSD 60 with standard body profile, standard carriage and coupling claw on one side, 1146 mm stroke

For combination kits and connecting elements refer to chapter 2.2