

# ATEK

ANTRIEBSTECHNIK

## Das Winkelgetriebe



Performance-optimized  
hypoid gearboxes

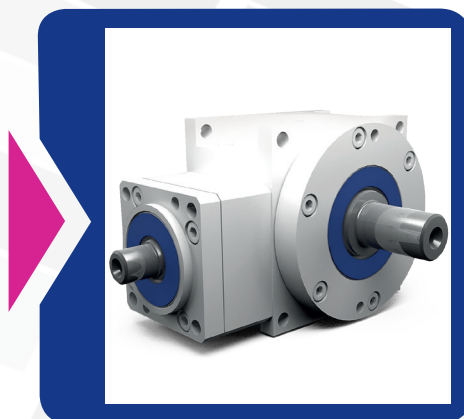

Miniature  
bevel gearboxes

Bevel  
gearboxes

Hygiene-design  
gearboxes

Hypoid  
gearboxes

Worm  
gearboxes

Gearbox  
motors

Servo gearboxes  
(precision gearboxes)

Special  
gearboxes

ATEX  
gearboxes

Gear sets

Service

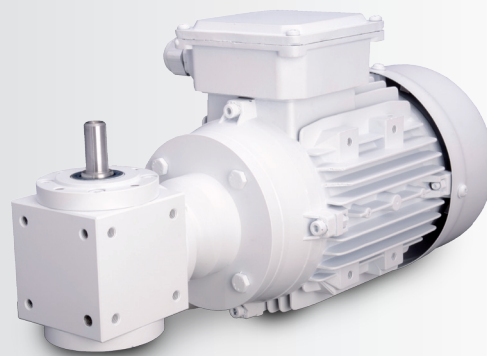

### 10.1 Type overview

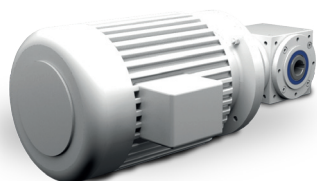

#### Type VLM – type VL with motor

Gear ratios:  $i = 1:1$  to  $6:1$   
Maximum output torque: 2310 Nm  
8 gearbox sizes with edge lengths of 065 to 260 mm  
Low-backlash construction < 6 angular minutes possible  
With mounted IEC standard motor  
Housing made of grey cast iron or steel

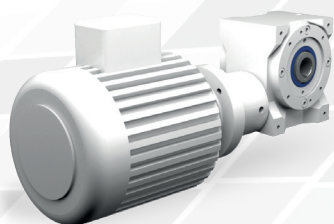

#### Type SLM – Type SL with motor

Nominal gear ratios:  $i = 5:1$  to  $83:1$   
Maximum output torque: 10,500 Nm  
8 sizes, centre-to-centre distance of 040 to 200 mm  
Low-backlash construction < 6 angular minutes possible  
With mounted IEC standard motor  
Housing made of grey cast iron

## 10.2 General construction

For the mounting of IEC standard motors, the drive shafts were changed such that the shaft journal of the motor can be inserted directly into the bore of the gearbox drive shaft. As types VLM and SLM, they are part of our product range.

The proven ATEK bevel gearbox and worm gearbox series form the basis for them. The combination of a large number of motor flanges and the insertable motor shaft journal enables the adaptation to a variety of IEC motors.

### 10.2.1 Motors

ATEK gearbox motors are available for ratings from 0.12 to 30 kW. The bevel gearbox motors are delivered with output speeds from 3000 to 140 rpm, the worm gearbox motors with output speeds from 590 to 8 rpm. Pole-changing motors, braking motors, explosion-proof motors and motors with pressure-proof enclosure are also available.

Type DS: three-phase asynchronous motor with cage rotor

Type DP: - pole-changing

Type DE: - explosion-proof

Type WS: single-phase AC motor

The motors conform to the relevant standards and regulations and the standardisation applied by the EC member states.

#### All motors come standard with:

- Insulation class "F"
- IP 55 protection rating
- Operating mode S1
- Model B5 or B14, DIN 42 950
- Normal voltage 230/400 V, 50 Hz  
230/400 V, 60 Hz
- In the efficiency class as valid from time to time

#### Bearing lubrication

The roller bearings of the motors have permanent grease lubrication and are, under normal operating conditions, maintenance-free for 12,000 to 20,000 service hours.

#### Voltage and frequency:

Motors wound for 50Hz may also be connected to 60Hz grids. The resulting changes in speed, output and torque are shown in the Table below. Conversion factors for the motor output data

Motor winding for 50Hz with:	Connection to 60Hz grid with:	Nominal speed	Nominal output	Nominal torque	Nominal current	Starting torque
<b>230V</b>	230 V	1.20	1.00	0.83	1.00	0.69
<b>400V</b>	400 V	1.20	1.00	0.83	1.00	0.69
<b>460V</b>	460 V	1.20	1.00	0.83	1.00	0.69
<b>500V</b>	500 V	1.20	1.00	0.83	1.00	0.69
<b>230V</b>	265 V	1.20	1.15	0.96	1.00	0.92
<b>400V</b>	460 V	1.20	1.15	0.96	1.00	0.92

Table 10.2.1-1

## Motor protection

For the pole-changing motors, it must be ensured that the windings are protected at all speeds. If appropriate, special switches will be required.

## Circuit breakers

In case of current-dependent motor protection, the circuit breaker must be set to the nominal current specified on the rating plate. In case of higher numbers of switching actuations, cooling temperature variations or speed control with frequency converters, the motor protection is insufficient.

## Complete PTC resistor protection

In case of complete PTC resistor protection, 3 temperature probes will be incorporated into the motor winding. The probes are temperature-dependent resistors that change the resistance almost abruptly at a specific response temperature. Combined with a triggering device, this effect is utilised to monitor the motor temperature.

## Switching operation

### Direct-on-line starting

In direct-on-line starting, the starting torque is 150 to 300% of the nominal torque, depending on power and number of poles. The input surge currents amount to the 4-fold to 6-fold of the nominal current. Due to the high starting current, the respective regulations of the concerned electric power utility must be observed.

### Star-delta starting

The breakaway starting current and the starting torque are about 1/3 of the values specified for direct-on-line starting. The motor must have reached approximately the nominal speed prior to the change-over.

## Braking motors

ATEK gearbox motors up to motor size 160 are also delivered as gear braking motors. The installed single-disc spring-loaded brake is a safety brake which brakes through spring force when the voltage has been switched off.

The direct-current brake coil is supplied via a rectifier installed in the motor. After the exciting current has been switched on, the magnetic field builds up, and the brake is released. In the as-new condition, the air gap between the brake solenoid and brake disc is set to 0.2 mm. If the maximum air gap of approx. 1.0 mm is exceeded the response time of the brake will increase strongly.

The air gap can be reset to 0.2 mm by adjustment.

Two braking motor types are available.

Type BL = low braking torques,  
Type BH = high braking torques.



# 10.3 Type VLM – Type VL with motor (gearbox motor)

## 10.3.1 Features

Gear ratios:  $i = 1:1$  to  $6:1$   
 Maximum output torque: 2310 Nm  
 8 gearbox sizes with edge lengths of 065 to 260 mm  
 Low-backlash construction < 6 angular minutes possible  
 With mounted IEC standard motor  
 Housing made of grey cast iron



## 10.3.2 Models

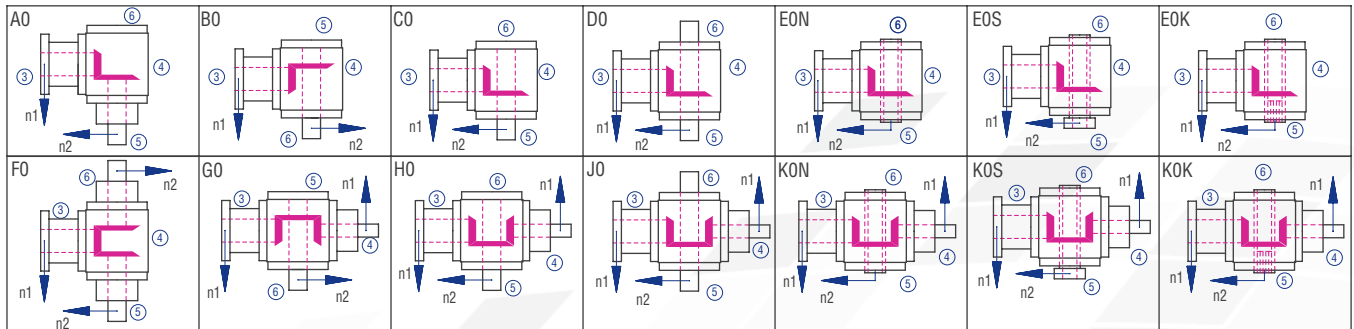

Figure 10.3.2-1; Models

## 10.3.3 Gearbox sides

The example shows the Model C0

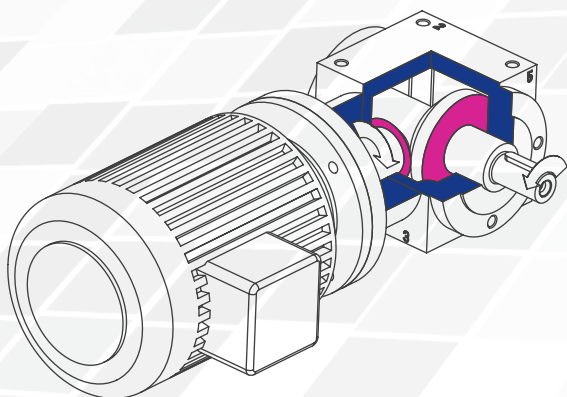

Figure 10.3.3-2; Gearbox sides

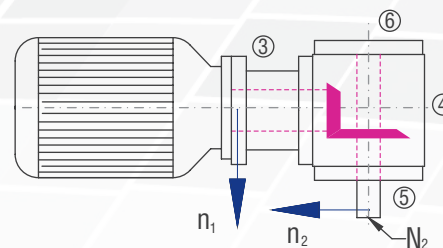

Figure 10.3.3-1; Shaft designations

## 10.3.4 Order code

The order code reflects the customer specifications. Example:

Type	Size	Gear ratio	Model	Fixing side	Installation position	Speed $n_2$	Design
VLM	090	1:1	C0-	1.	1-	1500	/0000
<b>Description</b>	Size; Table 10.3.5-1	Table 10.3.5-1	Figure 10.3.2-1	Gearbox side on which fixing is made; Table 6.2.3-1; Figure 4.3.1-1 Gearbox sides	Gearbox side directed downwards; Figure 4.3.1-1 Gearbox sides	Slowly rotating shaft; Table 10.3.5-1	Standard
	DS 080	4	/00	-5			
	Motor type	Number of poles	Additional version	Connection box to the side			

Motor type: DS 080; three-phase motor  
 Number of poles: 4; speed of approx. 1500 rpm at 50 Hz  
 Connection box: 5; the motor connection box points to the gearbox side 5









## 10.3.6 Type VLM 065 – Type VL with motor (gearbox motor)

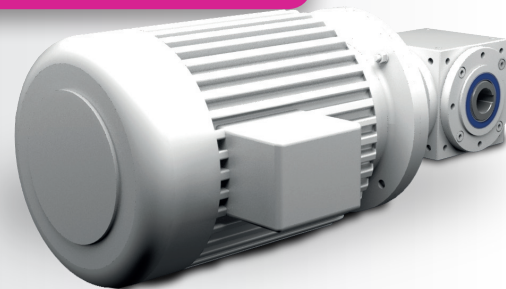

### Characteristics

Characteristic	Standard	Option
Toothing	Bevel gear, spiral-toothed	See chapter 6.2.1
Gear ratio	1:1 to 3:1	
Housing / Flanges	Grey cast iron	
Threaded mounting hole	On all housing surfaces without flange and on all flanges.	See chapter 6.2.3
Shaft	Material 1 C45, shaft ends greased Fit with ISO 6 tolerance with parallel keyway: according to DIN 6885 Sheet 1	See chapter 4.6.2
Hollow shaft	Material 1 C45, shafts greased Fit with ISO 7 tolerance with parallel keyway: according to DIN 6885 Sheet 1	See chapter 4.6.3
Radial shaft seal ring	NBR, form A	See chapter 4.8
Ambient temperature	-10°C to +90°C. The values of the performance tables are valid for +20°C	See chapter 4.9.3
Circumferential backlash	< 30 arcmin	See chapter 6.2.10
Protection class	IP 54	See chapter 4.5
Corrosion protection	Prime coat; layer thickness > 40 µm	See chapter 4.4.1
Bearing life L10h	more than 15,000h	See chapter 4.9.1
Oil change intervals	Not required if the oil temperature is kept < 90°C The lifetime of the bearings can be increased by the factor 1.5 if the oil is changed after the first 500 service hours and then every 5000 service hours.	See chapter 6.2.8
Lubricants	Synthetic lubricants	See chapter 6.2.8
Motor	IEC standard motor in the prescribed efficiency class	

### Permissible radial force $F_{r2}$ and axial force $F_{a2}$ on shaft $N_2$

$n_1$ [rpm]	3000		1000		500		250		100		50	
	$F_r$ [N]	$F_a$ [N]	$F_r$ [N]	$F_a$ [N]	$F_r$ [N]	$F_a$ [N]	$F_r$ [N]	$F_a$ [N]	$F_r$ [N]	$F_a$ [N]	$F_r$ [N]	$F_a$ [N]
< 12	300	150	400	200	500	250	650	325	750	375	900	450
> 12	250	125	330	165	420	210	540	270	630	315	750	375

Gearbox size	D [mm]	IEC motor	G [mm]	g [mm]	q [mm]	$q_1$ [mm]
065	120.00	063	125.00	95.00	189.00	211.00
065	140.00	071	148.00	115.00	208.00	228.00

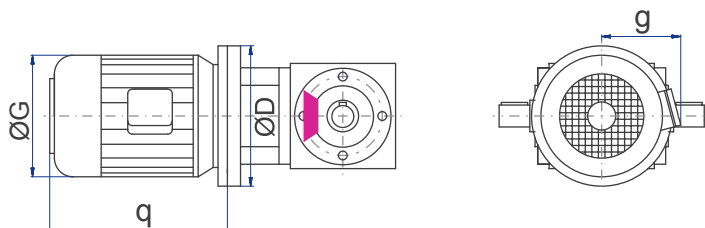
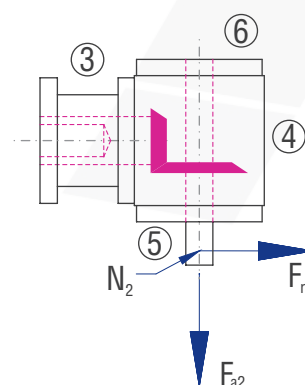

The mass inertia moment and the weight of the motor depend on the manufacturer. Please enquire the values of the overall system. For the dimensions of the bevel gearbox, please refer to the chapter 6.3 Standard bevel gearboxes

## Performance data

P <sub>1</sub> [kW]	n <sub>2</sub> [rpm]	T <sub>2</sub> [Nm]	T <sub>2N</sub> [Nm]	T <sub>2MAX</sub> [Nm]	i [-]	IEC motor	Gearbox size	P <sub>INT</sub> [kW]
0.12	1340	0.8	11	25	1:1	063A-4	065	1.6
	893	1.2	11	25	1.5:1	063A-4	065	1.6
	670	1.6	11	25	2:1	063A-4	065	1.6
	593	1.8	13	25	1.5:1	063B-6	065	1.6
	447	2.4	11	23	3:1	063A-4	065	1.6
	296	3.7	12	23	3:1	063B-6	065	1.6
0.18	2680	0.6	10	25	1:1	063A-2	065	1.6
	1787	0.9	10	25	1.5:1	063A-2	065	1.6
	1340	1.2	10	25	1:1	063B-4	065	1.6
	893	1.8	10	25	1.5:1	063B-4	065	1.6
	670	2.4	10	25	2:1	063B-4	065	1.6
	593	2.8	10	25	1.5:1	071A-6	065	1.6
	450	3.6	11	23	3:1	063B-4	065	1.6
	445	3.7	10	25	2:1	071A-6	065	1.6
296	5.5	11	23	3:1	071A-6	065	1.6	
0.25	2700	0.8	10	25	1:1	063B-2	065	1.6
	1800	1.3	10	25	1.5:1	063B-2	065	1.6
	1350	1.7	10	25	1:1	071A-4	065	1.6
	890	2.6	10	25	1:1	071B-6	065	1.6
	675	3.4	10	25	2:1	071A-4	065	1.6
	450	5.0	11	25	3:1	071A-4	065	1.6
0.37	2800	1.2	10	25	1:1	071A-2	065	1.6
	1400	2.4	10	25	2:1	071A-2	065	1.6
	1350	2.5	10	25	1:1	071B-4	065	1.6
	933	3.6	10	23	3:1	071A-2	065	1.6
	675	5.0	10	25	2:1	071B-4	065	1.6
0.55	2810	1.8	10	25	1:1	071B-2	065	1.6
	1873	2.7	10	23	1.5:1	071B-2	065	1.6
	1405	3.6	10	25	2:1	071B-2	065	1.6
	936	5.3	10	23	3:1	071B-2	065	1.6

## 10.3.7 Type VLM 090 – Type VL with motor (gearbox motor)

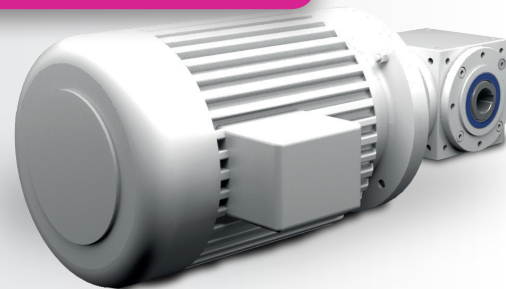

### Characteristics

Characteristic	Standard	Option
Toothing	Bevel gear, spiral-toothed	See chapter 6.2.1
Gear ratio	3:1 to 6:1	
Housing / Flanges	Grey cast iron	
Threaded mounting hole	On all housing surfaces without flange and on all flanges.	See chapter 6.2.3
Shaft	Material 1 C45, shaft ends greased Fit with ISO 6 tolerance with parallel keyway: according to DIN 6885 Sheet 1	See chapter 4.6.2
Hollow shaft	Material 1 C45, shafts greased Fit with ISO 7 tolerance with parallel keyway: according to DIN 6885 Sheet 1	See chapter 4.6.3
Radial shaft seal ring	NBR, form A	See chapter 4.8
Ambient temperature	-10°C to +90°C. The values of the performance tables are valid for +20°C	See chapter 4.9.3
Circumferential backlash	< 30 arcmin	See chapter 6.2.10
Protection class	IP 54	See chapter 4.5
Corrosion protection	Prime coat; layer thickness > 40 µm	See chapter 4.4.1
Bearing life L10h	more than 15,000h	See chapter 4.9.1
Oil change intervals	Not required if the oil temperature is kept < 90°C The lifetime of the bearings can be increased by the factor 1.5 if the oil is changed after the first 500 service hours and then every 5000 service hours.	See chapter 6.2.8
Lubricants	Synthetic lubricants	See chapter 6.2.8
Motor	IEC standard motor in the prescribed efficiency class	

### Permissible radial force $F_{r2}$ and axial force $F_{a2}$ on shaft $N_2$

$n_1$ [rpm]	3000		1000		500		250		100		50	
	$F_r$ [N]	$F_a$ [N]	$F_r$ [N]	$F_a$ [N]	$F_r$ [N]	$F_a$ [N]	$F_r$ [N]	$F_a$ [N]	$F_r$ [N]	$F_a$ [N]	$F_r$ [N]	$F_a$ [N]
< 30	500	250	660	330	800	400	950	475	1250	625	1500	750
> 30	420	210	550	275	670	335	790	395	1040	520	1250	625

Gearbox size	D [mm]	IEC motor	G [mm]	g [mm]	q [mm]	$q_1$ [mm]
090	120.00	063	125.00	95.00	189.00	211.00
090	140.00	071	148.00	115.00	208.00	228.00
090	120.00	080	170.00	126.00	234.00	245.00

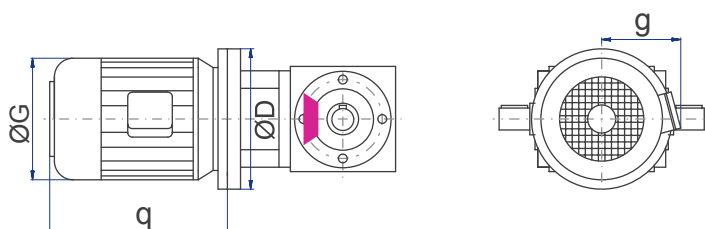
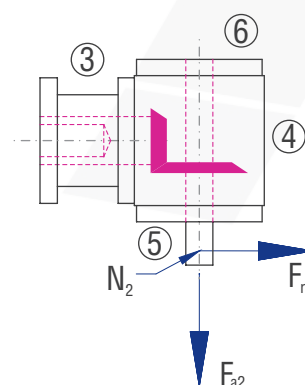

The mass inertia moment and the weight of the motor depend on the manufacturer. Please enquire the values of the overall system. For the dimensions of the bevel gearbox, please refer to the chapter 6.3 Standard bevel gearboxes

## Performance data

P <sub>1</sub> [kW]	n <sub>2</sub> [rpm]	T <sub>2</sub> [Nm]	T <sub>2N</sub> [Nm]	T <sub>2MAX</sub> [Nm]	i [-]	IEC motor	Gearbox size	P <sub>1NT</sub> [kW]
0.18	335	4.9	27	70	4:1	063B-4	090	3.8
	268	6.1	27	60	5:1	063B-4	090	3.8
	224	7.3	25	50	6:1	063B-4	090	3.8
	178	9.2	31	60	5:1	071A-6	090	3.8
	167	9.8	32	70	4:1	080A-8	090	3.8
	148	11.0	29	50	6:1	071A-6	090	3.8
	112	14.6	30	50	6:1	080A-8	090	3.8
0.25	540	4.2	23	60	5:1	063B-2	090	3.8
	450	5.0	27	70	3:1	071A-4	090	3.8
	337	6.7	27	70	4:1	071A-4	090	3.8
	296	7.7	31	70	3:1	071B-6	090	3.8
	270	8.4	27	60	5:1	071A-4	090	3.8
	225	10.1	25	50	6:1	071A-4	090	3.8
	178	12.7	31	60	5:1	071B-6	090	3.8
	148	15.3	29	50	6:1	071B-6	090	3.8
	134	16.9	32	60	5:1	080B-8	090	3.8
	112	20.3	30	50	6:1	080B-8	090	3.8
0.37	900	3.7	29	40	1.5:1	071B-4	090	3.8
	675	5.0	27	30	2:1	071B-4	090	3.8
	600	5.6	32	40	1.5:1	080A-6	090	3.8
	560	6.0	23	60	5:1	071A-2	090	3.8
	450	7.5	27	70	3:1	071B-4	090	3.8
	337	10.0	27	70	4:1	071B-4	090	3.8
	270	12.4	27	60	5:1	071B-4	090	3.8
	225	14.9	25	50	6:1	071B-4	090	3.8
	180	18.7	31	60	5:1	080A-6	090	3.8
	150	22.4	29	50	6:1	080A-6	090	3.8
0.55	936	5.3	23	70	3:1	071B-2	090	3.8
	906	5.5	29	40	1.5:1	080A-4	090	3.8
	702	7.1	23	70	4:1	071B-2	090	3.8
	680	7.3	27	30	2:1	080A-4	090	3.8
	600	8.3	32	40	1.5:1	080B-6	090	3.8
	562	8.9	23	60	5:1	071B-2	090	3.8
	453	11.0	27	70	3:1	080A-4	090	3.8
	340	14.7	27	70	4:1	080A-4	090	3.8
	300	16.6	31	70	3:1	080B-6	090	3.8
	227	22.0	25	50	6:1	080A-4	090	3.8
	180	27.7	31	60	5:1	080B-6	090	3.8
0.75	1880	3.6	25	40	1.5:1	080A-2	090	3.8
	1410	4.8	23	30	2:1	080A-2	090	3.8
	1360	5.0	32	105	1:1	080B-4	090	3.8
	940	7.2	23	70	3:1	080A-2	090	3.8
	906	7.5	29	40	1.5:1	080B-4	090	3.8
	705	9.7	23	70	4:1	080A-2	090	3.8
	680	10.0	27	30	2:1	080B-4	090	3.8
	564	12.1	27	60	5:1	080A-2	090	3.8
	453	15.0	27	70	3:1	080B-4	090	3.8
	340	20.0	27	70	4:1	080B-4	090	3.8
1.1	2820	3.5	27	105	1:1	080B-2	090	3.8
	1880	5.3	25	40	1.5:1	080B-2	090	3.8
	1410	7.1	23	30	2:1	080B-2	090	3.8
	940	10.6	23	70	3:1	080B-2	090	3.8
	705	14.2	23	70	4:1	080B-2	090	3.8

## 10.3.8 Type VLM 120 – Type VL with motor (gearbox motor)

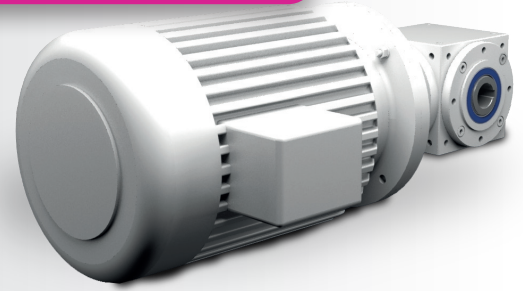

### Characteristics

Characteristic	Standard	Option
Toothings	Bevel gear, spiral-toothed	See chapter 6.2.1
Gear ratio	3:1 to 6:1	
Housing / Flanges	Grey cast iron	
Threaded mounting hole	On all housing surfaces without flange and on all flanges.	See chapter 6.2.3
Shaft	Material 1 C45, shaft ends greased Fit with ISO 6 tolerance with parallel keyway: according to DIN 6885 Sheet 1	See chapter 4.6.2
Hollow shaft	Material 1 C45, shafts greased Fit with ISO 7 tolerance with parallel keyway: according to DIN 6885 Sheet 1	See chapter 4.6.3
Radial shaft seal ring	NBR, form A	See chapter 4.8
Ambient temperature	-10°C to +90°C. The values of the performance tables are valid for +20°C	See chapter 4.9.3
Cumferential backlash	< 30 arcmin	See chapter 6.2.10
Protection class	IP 54	See chapter 4.5
Corrosion protection	Prime coat; layer thickness > 40 µm	See chapter 4.4.1
Bearing life L10h	more than 15,000h	See chapter 4.9.1
Oil change intervals	Not required if the oil temperature is kept < 90°C The lifetime of the bearings can be increased by the factor 1.5 if the oil is changed after the first 500 service hours and then every 5000 service hours.	See chapter 6.2.8
Lubricants	Synthetic lubricants	See chapter 6.2.8
Motor	IEC standard motor in the prescribed efficiency class	

### Permissible radial force $F_{r2}$ and axial force $F_{a2}$ on shaft $N_2$

$n_1$ [rpm]	3000		1000		500		250		100		50		
	$T_2$ [Nm]	$F_r$ [N]	$F_a$ [N]	$F_r$ [N]	$F_a$ [N]	$F_r$ [N]	$F_a$ [N]	$F_r$ [N]	$F_a$ [N]	$F_r$ [N]	$F_a$ [N]	$F_r$ [N]	$F_a$ [N]
< 80		750	375	1000	500	1250	625	1500	750	1900	950	2200	1100
> 80		630	315	830	415	1040	520	1250	625	1580	790	1830	915

Gearbox size	D [mm]	IEC motor	G [mm]	g [mm]	q [mm]	$q_1$ [mm]
120	160.00	080	170.00	126.00	234.00	245.00
120	160.00	090L	185.00	142.00	272.00	298.00
120	160.00	090S	185.00	142.00	247.00	273.00
120	200.00	100	210.00	155.00	301.00	348.00
120	200.00	112	210.00	155.00	301.00	348.00

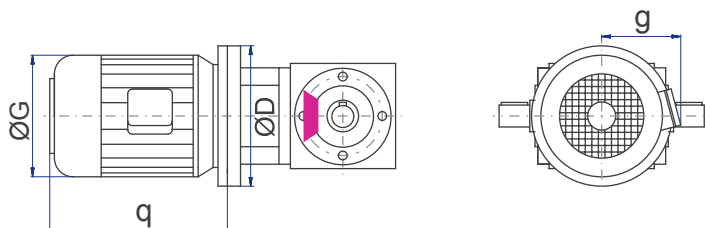
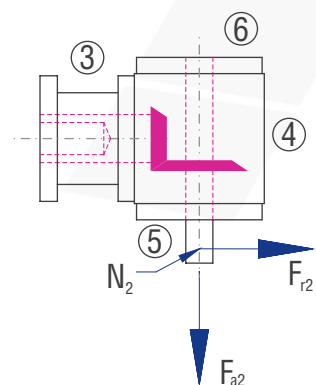

The mass inertia moment and the weight of the motor depend on the manufacturer. Please enquire the values of the overall system. For the dimensions of the bevel gearbox, please refer to the chapter 6.3 Standard bevel gearboxes

## Performance data

P <sub>1</sub> [kW]	n <sub>2</sub> [rpm]	T <sub>2</sub> [Nm]	T <sub>2N</sub> [Nm]	T <sub>2MAX</sub> [Nm]	i [-]	IEC motor	Gearbox size	P <sub>1NT</sub> [kW]
0.55	272	18.4	72	140	5:1	080A-4	120	6.2
	172	28.9	82	155	4:1	090L-8	120	6.2
	150	33.3	67	120	6:1	080B-6	120	6.2
	138	36.2	86	140	5:1	090L-8	120	6.2
	115	43.4	69	120	6:1	090L-8	120	6.2
0.75	606	11.2	86	100	1.5:1	090S-6	120	6.2
	303	22.4	82	155	3:1	090S-6	120	6.2
	272	25.0	72	140	5:1	080B-4	120	6.2
	227	30.0	64	120	6:1	080B-4	120	6.2
	182	37.4	80	140	5:1	090S-6	120	6.2
	152	44.8	67	113	6:1	090S-6	120	6.2
	138	49.3	86	140	5:1	100LA-8	120	6.2
	115	59.2	69	118	6:1	00LA-8	120	6.2
1.1	920	10.9	78	100	1.5:1	090S-4	120	6.2
	690	14.5	73	80	2:1	090S-4	120	6.2
	606	16.5	86	100	1.5:1	090L-6	120	6.2
	564	17.7	60	140	5:1	080B-2	120	6.2
	460	21.7	74	155	3:1	090S-4	120	6.2
	345	28.9	74	155	4:1	090S-4	120	6.2
	303	32.9	82	155	3:1	090L-6	120	6.2
	276	36.2	72	140	5:1	090S-4	120	6.2
	227	43.9	79	155	4:1	090L-6	120	6.2
	182	54.8	80	140	5:1	090L-6	120	6.2
	152	65.7	67	120	6:1	090L-6	120	6.2
	138	72.3	86	140	5:1	100LB-8	120	6.2
	15	1420	9.6	56	80	2:1	090S-2	120
946		14.4	58	155	3:1	090S-2	120	6.2
920		14.8	78	100	1.5:1	090L-4	120	6.2
710		19.2	60	155	4:1	090S-2	120	6.2
690		19.7	73	80	2:1	090L-4	120	6.2
613		22.2	78	100	1.5:1	100LA-6	120	6.2
568		24.0	60	140	5:1	090S-2	120	6.2
460		29.6	74	155	3:1	090L-4	120	6.2
345		39.5	74	155	4:1	090L-4	120	6.2
306		44.4	82	155	3:1	100LA-6	120	6.2
276		49.3	72	140	5:1	090L-4	120	6.2
230		59.2	64	120	6:1	090L-4	120	6.2
184		74.0	80	140	5:1	100LA-6	120	6.2
2.2	1893	10.5	61	100	1.5:1	090L-2	120	6.2
	1420	14.1	56	80	2:1	090L-2	120	6.2
	940	21.2	78	100	1.5:1	100LA-4	120	6.2
	710	28.1	60	155	4:1	090L-2	120	6.2
	626	31.9	80	100	1.5:1	112M-6	120	6.2
	568	35.1	60	140	5:1	090L-2	120	6.2
	470	42.5	74	155	3:1	100LA-4	120	6.2
	352	56.6	74	155	4:1	100LA-4	120	6.2
	313	63.7	82	155	3:1	112M-6	120	6.2
3	2850	9.6	66	220	1:1	100L-2	120	6.2
	1900	14.3	61	100	1.5:1	100L-2	120	6.2
	1410	19.3	82	220	1:1	100LB-4	120	6.2
	940	29.0	78	100	1.5:1	100LB-4	120	6.2
	705	38.6	73	80	2:1	100LB-4	120	6.2
	570	47.8	60	140	5:1	100L-2	120	6.2
	470	57.9	74	155	3:1	100LB-4	120	6.2
4	2860	12.7	66	220	1:1	112M-2	120	6.2
	1906	19.0	61	100	1.5:1	112M-2	120	6.2
	1420	25.6	82	220	1:1	112M-4	120	6.2
	946	38.3	78	100	1.5:1	112M-4	120	6.2
	710	51.1	73	80	2:1	112M-4	120	6.2

## 10.3.9 Type VLM 140 – Type VL with motor (gearbox motor)

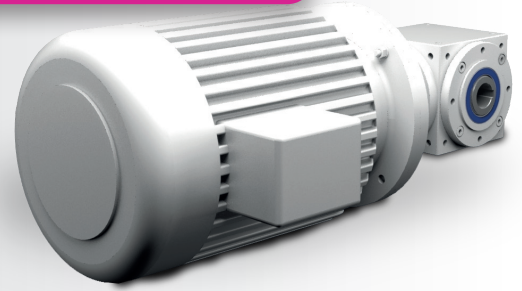

### Characteristics

Characteristic	Standard	Option
Toothing	Bevel gear, spiral-toothed	See chapter 6.2.1
Gear ratio	3:1 to 6:1	
Housing / Flanges	Grey cast iron	
Threaded mounting hole	On all housing surfaces without flange and on all flanges.	See chapter 6.2.3
Shaft	Material 1 C45, shaft ends greased Fit with ISO 6 tolerance with parallel keyway: according to DIN 6885 Sheet 1	See chapter 4.6.2
Hollow shaft	Material 1 C45, shafts greased Fit with ISO 7 tolerance with parallel keyway: according to DIN 6885 Sheet 1	See chapter 4.6.3
Radial shaft seal ring	NBR, form A	See chapter 4.8
Ambient temperature	-10°C to +90°C. The values of the performance tables are valid for +20°C	See chapter 4.9.3
Cumferential backlash	< 30 arcmin	See chapter 6.2.10
Protection class	IP 54	See chapter 4.5
Corrosion protection	Prime coat; layer thickness > 40 µm	See chapter 4.4.1
Bearing life L10h	more than 15,000h	See chapter 4.9.1
Oil change intervals	Not required if the oil temperature is kept < 90°C The lifetime of the bearings can be increased by the factor 1.5 if the oil is changed after the first 500 service hours and then every 5000 service hours.	See chapter 6.2.8
Lubricants	Synthetic lubricants	See chapter 6.2.8
Motor	IEC standard motor in the prescribed efficiency class	

### Permissible radial force $F_{r2}$ and axial force $F_{a2}$ on shaft $N_2$

$n_1$ [rpm]	3000		1000		500		250		100		50	
	$F_r$ [N]	$F_a$ [N]	$F_r$ [N]	$F_a$ [N]	$F_r$ [N]	$F_a$ [N]	$F_r$ [N]	$F_a$ [N]	$F_r$ [N]	$F_a$ [N]	$F_r$ [N]	$F_a$ [N]
< 140	1300	650	1700	850	2000	1000	2500	1250	3000	1500	3800	1900
> 140	1082	541	1420	710	1670	835	2080	1040	2500	1250	3170	1585

Gearbox size	D [mm]	IEC motor	G [mm]	g [mm]	q [mm]	$q_1$ [mm]
140	200.00	100	210.00	155.00	301.00	348.00
140	200.00	112	210.00	155.00	301.00	348.00
140	200.00	132M	260.00	200.00	416.00	454.00
140	200.00	132S	260.00	200.00	390.00	428.00

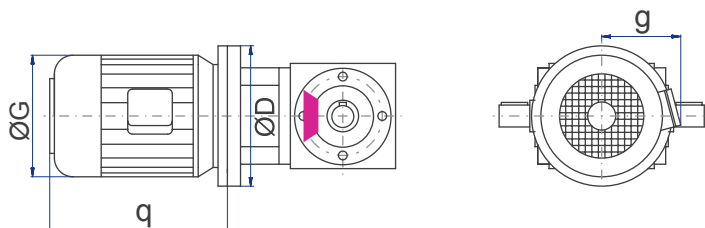
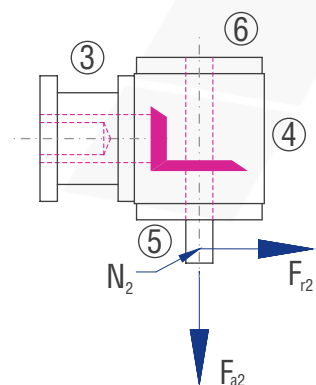

The mass inertia moment and the weight of the motor depend on the manufacturer. Please enquire the values of the overall system. For the dimensions of the bevel gearbox, please refer to the chapter 6.3 Standard bevel gearboxes



## Performance data

P <sub>1</sub> [kW]	n <sub>2</sub> [rpm]	T <sub>2</sub> [Nm]	T <sub>2N</sub> [Nm]	T <sub>2MAX</sub> [Nm]	i [-]	IEC motor	Gearbox size	P <sub>1NT</sub> [kW]
1.5	154	88.4	113	200	6:1	100LA-6	140	10
	140	97.2	130	250	5:1	112M-8	140	10
	117	116.3	118	200	6:1	112M-8	140	10
2.2	188	106.2	124	250	5:1	112M-6	140	10
3	633	43.0	175	210	1.5:1	132SB-6	140	10
	475	57.3	152	180	2:1	132SB-6	140	10
	316	86.0	160	280	3:1	132SB-6	140	10
	282	96.5	115	250	5:1	100LB-4	140	10
	237	114.6	136	280	4:1	132SB-6	140	10
4	633	57.3	175	210	1.5:1	132MA-6	140	10
	572	63.4	100	250	5:1	112M-2	140	10
	475	76.4	152	180	2:1	132MA-6	140	10
	355	102.2	120	280	4:1	112M-4	140	10
	316	114.6	160	280	3:1	132MA-6	140	10
5.5	2900	17.3	120	430	1:1	132SA-2	140	10
	1933	26.0	113	210	1.5:1	132SA-2	140	10
	1430	34.9	162	430	1:1	132SB-4	140	10
	953	52.3	155	210	1.5:1	132SB-4	140	10
	715	69.8	138	180	2:1	132SB-4	140	10
	633	78.8	175	210	1.5:1	132MB-6	140	10
	580	86.0	100	250	5:1	132SA-2	140	10
	476	104.7	146	280	3:1	132SB-4	140	10
	316	157.6	160	280	3:1	132MB-6	140	10
7.5	2900	23.5	120	430	1:1	132SB-2	140	10
	1933	35.2	113	180	1.5:1	132SB-2	140	10
	1430	47.6	162	430	1:1	132MB-4	140	10
	966	70.4	110	280	3:1	132SB-2	140	10
	953	71.4	155	210	1.5:1	132MB-4	140	10
	715	95.2	138	180	2:1	132MB-4	140	10
	476	142.8	146	280	3:1	132MB-4	140	10
	2910	28.1	120	430	1:1	132MA-2	140	10
9	1940	42.1	113	210	1.5:1	132MA-2	140	10
	1430	57.1	162	430	1:1	132MC-4	140	10
	953	85.7	155	210	1.5:1	132MC-4	140	10
	715	114.2	138	180	2:1	132MC-4	140	10

Gearbox  
motors

## 10.3.10 Type VLM 160 – Type VL with motor (gearbox motor)

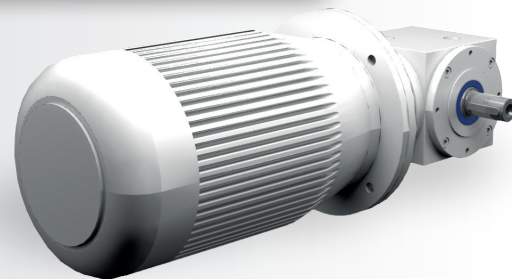

### Characteristics

Characteristic	Standard	Option
Toothing	Bevel gear, spiral-toothed	See chapter 6.2.1
Gear ratio	3:1 to 6:1	
Housing / Flanges	Grey cast iron	
Threaded mounting hole	On all housing surfaces without flange and on all flanges.	See chapter 6.2.3
Shaft	Material 1 C45, shaft ends greased Fit with ISO 6 tolerance with parallel keyway: according to DIN 6885 Sheet 1	See chapter 4.6.2
Hollow shaft	Material 1 C45, shafts greased Fit with ISO 7 tolerance with parallel keyway: according to DIN 6885 Sheet 1	See chapter 4.6.3
Radial shaft seal ring	NBR, form A	See chapter 4.8
Ambient temperature	-10°C to +90°C. The values of the performance tables are valid for +20°C	See chapter 4.9.3
Cumferential backlash	< 30 arcmin	See chapter 6.2.10
Protection class	IP 54	See chapter 4.5
Corrosion protection	Prime coat; layer thickness > 40 µm	See chapter 4.4.1
Bearing life L10h	more than 15,000h	See chapter 4.9.1
Oil change intervals	Not required if the oil temperature is kept < 90°C The lifetime of the bearings can be increased by the factor 1.5 if the oil is changed after the first 500 service hours and then every 5000 service hours.	See chapter 6.2.8
Lubricants	Synthetic lubricants	See chapter 6.2.8
Motor	IEC standard motor in the prescribed efficiency class	

### Permissible radial force $F_{r2}$ and axial force $F_{a2}$ on shaft $N_2$

$n_1$ [rpm]	3000		1000		500		250		100		50		
	$T_2$ [Nm]	$F_r$ [N]	$F_a$ [N]	$F_r$ [N]	$F_a$ [N]	$F_r$ [N]	$F_a$ [N]	$F_r$ [N]	$F_a$ [N]	$F_r$ [N]	$F_a$ [N]	$F_r$ [N]	$F_a$ [N]
< 220		2000	1000	2800	1400	3300	1650	4000	2000	5000	2500	6500	3250
> 220		1670	835	2340	1170	2750	1375	3340	1670	4170	2085	5420	2710

Gearbox size	D [mm]	IEC motor	G [mm]	g [mm]	q [mm]	$q_1$ [mm]
160	200.00	100	210.00	155.00	301.00	348.00
160	200.00	112	210.00	155.00	301.00	348.00
160	200.00	132M	260.00	200.00	416.00	454.00
160	200.00	132S	260.00	200.00	390.00	428.00

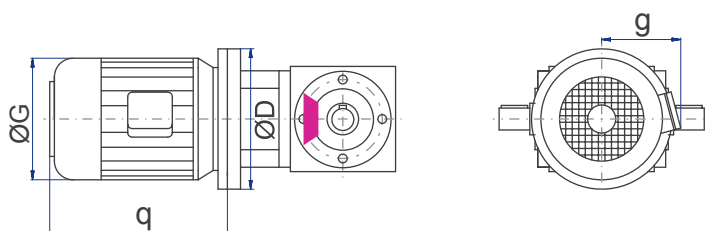
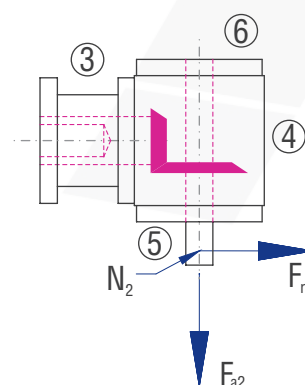

The mass inertia moment and the weight of the motor depend on the manufacturer. Please enquire the values of the overall system. For the dimensions of the bevel gearbox, please refer to the chapter 6.3 Standard bevel gearboxes

## Performance data

P <sub>1</sub> [kW]	n <sub>2</sub> [rpm]	T <sub>2</sub> [Nm]	T <sub>2N</sub> [Nm]	T <sub>2MAX</sub> [Nm]	i [-]	IEC motor	Gearbox size	P <sub>1NT</sub> [kW]
2.2	157	127.1	165	200	6:1	112M-6	160	15
	141	141.6	240	420	5:1	132SB-8	160	15
	118	169.2	178	200	6:1	132SB-8	160	15
3	235	115.8	145	350	6:1	100LB-4	160	15
	190	143.3	225	420	5:1	132SB-6	160	15
	177	153.3	250	422	4:1	132MB-8	160	15
	142	191.7	240	420	5:1	132MB-8	160	15
4	355	102.2	220	422	4:1	112M-4	160	15
	284	127.8	215	420	5:1	112M-4	160	15
	237	152.8	240	422	4:1	132MA-6	160	15
	190	191.0	225	420	5:1	132MA-6	160	15
5.5	476	104.7	230	457	3:1	132SB-4	160	15
	357	139.6	220	422	4:1	132SB-4	160	15
	316	157.6	245	457	3:1	132MB-6	160	15
	286	174.5	215	420	5:1	132SB-4	160	15
	237	210.1	240	422	4:1	132MB-6	160	15
7.5	580	117.3	180	420	5:1	132SB-2	160	15
	476	142.8	230	457	3:1	132MB-4	160	15
	357	190.3	220	422	4:1	132MB-4	160	15
9	1430	57.1	260	660	1:1	132MC-4	160	15
	970	84.2	190	457	3:1	132MA-2	160	15
	953	85.7	252	360	1.5:1	132MC-4	160	15
	727	112.2	180	422	4:1	132MA-2	160	15
	715	114.2	245	320	2:1	132MC-4	160	15
	582	140.3	180	420	5:1	132MA-2	160	15
	476	171.3	230	457	3:1	132MC-4	160	15
	357	228.4	220	422	4:1	132MC-4	160	15

## 10.3.11 Type VLM 200 – Type VL with motor (gearbox motor)

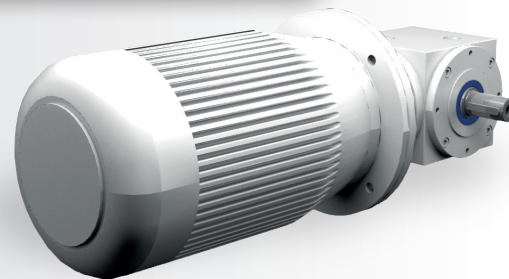

### Characteristics

Characteristic	Standard	Option
Toothing	Bevel gear, spiral-toothed	See chapter 6.2.1
Gear ratio	3:1 to 6:1	
Housing / Flanges	Grey cast iron	
Threaded mounting hole	On all housing surfaces without flange and on all flanges.	See chapter 6.2.3
Shaft	Material 1 C45, shaft ends greased Fit with ISO 6 tolerance with parallel keyway: according to DIN 6885 Sheet 1	See chapter 4.6.2
Hollow shaft	Material 1 C45, shafts greased Fit with ISO 7 tolerance with parallel keyway: according to DIN 6885 Sheet 1	See chapter 4.6.3
Radial shaft seal ring	NBR, form A	See chapter 4.8
Ambient temperature	-10°C to +90°C. The values of the performance tables are valid for +20°C	See chapter 4.9.3
Cumferential backlash	< 30 arcmin	See chapter 6.2.10
Protection class	IP 54	See chapter 4.5
Corrosion protection	Prime coat; layer thickness > 40 µm	See chapter 4.4.1
Bearing life L10h	more than 15,000h	See chapter 4.9.1
Oil change intervals	Not required if the oil temperature is kept < 90°C The lifetime of the bearings can be increased by the factor 1.5 if the oil is changed after the first 500 service hours and then every 5000 service hours.	See chapter 6.2.8
Lubricants	Synthetic lubricants	See chapter 6.2.8
Motor	IEC standard motor in the prescribed efficiency class	

### Permissible radial force $F_{r2}$ and axial force $F_{a2}$ on shaft $N_2$

$n_1$ [rpm]	3000		1000		500		250		100		50	
	$F_r$ [N]	$F_a$ [N]	$F_r$ [N]	$F_a$ [N]	$F_r$ [N]	$F_a$ [N]	$F_r$ [N]	$F_a$ [N]	$F_r$ [N]	$F_a$ [N]	$F_r$ [N]	$F_a$ [N]
< 220	2000	1000	2800	1400	3300	1650	4000	2000	5000	2500	6500	3250
> 220	1670	835	2340	1170	2750	1375	3340	1670	4170	2085	5420	2710

Gearbox size	D [mm]	IEC motor	G [mm]	g [mm]	q [mm]	$q_1$ [mm]
200	200.00	132M	260.00	200.00	416.00	454.00
200	350.00	160	320.00	245.00	540.00	0.00
200	350.00	180	320.00	245.00	580.00	0.00

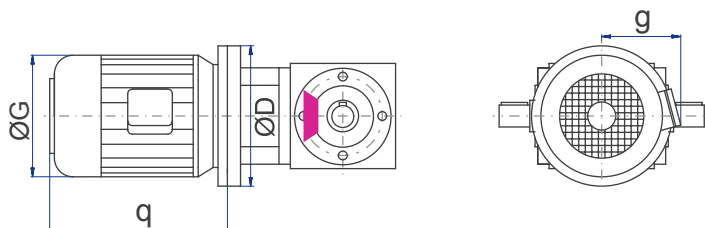
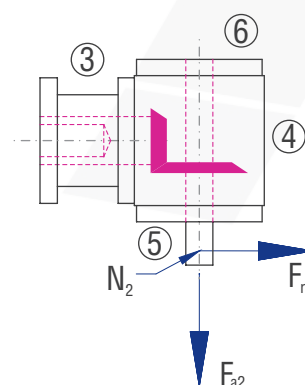

The mass inertia moment and the weight of the motor depend on the manufacturer. Please enquire the values of the overall system. For the dimensions of the bevel gearbox, please refer to the chapter 6.3 Standard bevel gearboxes

## Performance data

P <sub>1</sub> [kW]	n <sub>2</sub> [rpm]	T <sub>2</sub> [Nm]	T <sub>2N</sub> [Nm]	T <sub>2MAX</sub> [Nm]	i [-]	IEC motor	Gearbox size	P <sub>1NT</sub> [kW]
4	177	204.5	510	860	4:1	160MA-8	200	26
	142	255.6	440	860	5:1	160MA-8	200	26
5.5	238	209.4	580	910	3:1	160LA-8	200	26
	190	262.6	420	860	5:1	132MB-6	200	26
	143	348.9	440	860	5:1	160LA-8	200	26
7.5	640	106.3	505	600	1.5:1	160MB-6	200	26
	480	141.8	500	530	2:1	160MB-6	200	26
	320	212.6	555	910	3:1	160MB-6	200	26
	286	237.9	380	860	5:1	132MB-4	200	26
	240	283.5	485	860	4:1	160MB-6	200	26
	192	354.4	420	860	5:1	160MB-6	200	26
9	286	285.5	380	860	5:1	132MC-4	200	26
11	1940	51.4	330	600	1.5:1	160MA-2	200	26
	1465	68.1	450	1090	1:1	160MB-4	200	26
	976	102.2	437	600	1.5:1	160MB-4	200	26
	732	136.2	425	530	2:1	160MB-4	200	26
	640	155.9	505	600	1.5:1	160LA-6	200	26
	582	171.5	300	860	5:1	160MA-2	200	26
	488	204.4	515	910	3:1	160MB-4	200	26
	366	272.5	455	860	4:1	160MB-4	200	26
	293	340.6	380	860	5:1	160MB-4	200	26
	240	415.8	485	860	4:1	160LA-6	200	26
15	1953	69.7	330	600	1.5:1	160MB-2	200	26
	1465	92.9	450	1090	1:1	160LA-4	200	26
	976	139.3	437	600	1.5:1	160LA-4	200	26
	732	185.8	425	530	2:1	160LA-4	200	26
	646	210.4	505	600	1.5:1	180L-6	200	26
	586	232.2	300	860	5:1	160MB-2	200	26
	488	278.7	515	910	3:1	160LA-4	200	26
	366	371.6	455	860	4:1	160LA-4	200	26
18.5	1960	85.6	330	600	1.5:1	160L-2	200	26
	1470	114.2	450	1090	1:1	180M-4	200	26
	980	171.3	437	600	1.5:1	180M-4	200	26
	735	228.4	425	530	2:1	180M-4	200	26
	588	285.4	300	860	5:1	160L-2	200	26
	490	342.5	515	910	3:1	180M-4	200	26
	367	456.7	455	860	4:1	180M-4	200	26
22	1470	135.8	450	1090	1:1	180L-4	200	26
	980	203.7	437	600	1.5:1	180L-4	200	26
	735	271.6	425	530	2:1	180L-4	200	26
	490	407.3	515	910	3:1	180L-4	200	26

Gearbox  
motors

## 10.3.12 Type VLM 230 – Type VL with motor (gearbox motor)

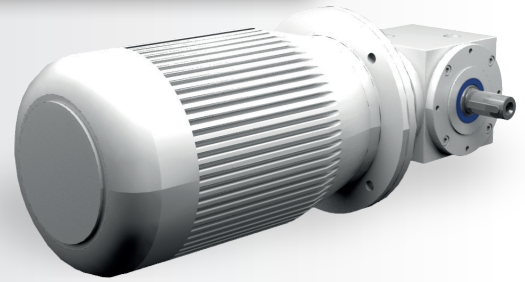

### Characteristics

Characteristic	Standard	Option
Toothing	Bevel gear, spiral-toothed	See chapter 6.2.1
Gear ratio	3:1 to 6:1	
Housing / Flanges	Grey cast iron	
Threaded mounting hole	On all housing surfaces without flange and on all flanges.	See chapter 6.2.3
Shaft	Material 1 C45, shaft ends greased Fit with ISO 6 tolerance with parallel keyway: according to DIN 6885 Sheet 1	See chapter 4.6.2
Hollow shaft	Material 1 C45, shafts greased Fit with ISO 7 tolerance with parallel keyway: according to DIN 6885 Sheet 1	See chapter 4.6.3
Radial shaft seal ring	NBR, form A	See chapter 4.8
Ambient temperature	-10°C to +90°C. The values of the performance tables are valid for +20°C	See chapter 4.9.3
Cumferential backlash	< 30 arcmin	See chapter 6.2.10
Protection class	IP 54	See chapter 4.5
Corrosion protection	Prime coat; layer thickness > 40 µm	See chapter 4.4.1
Bearing life L10h	more than 15,000h	See chapter 4.9.1
Oil change intervals	Not required if the oil temperature is kept < 90°C The lifetime of the bearings can be increased by the factor 1.5 if the oil is changed after the first 500 service hours and then every 5000 service hours.	See chapter 6.2.8
Lubricants	Synthetic lubricants	See chapter 6.2.8
Motor	IEC standard motor in the prescribed efficiency class	

### Permissible radial force $F_{r2}$ and axial force $F_{a2}$ on shaft $N_2$

$n_1$ [rpm]	3000		1000		500		250		100		50	
$T_2$ [Nm]	$F_r$ [N]	$F_a$ [N]	$F_r$ [N]	$F_a$ [N]	$F_r$ [N]	$F_a$ [N]	$F_r$ [N]	$F_a$ [N]	$F_r$ [N]	$F_a$ [N]	$F_r$ [N]	$F_a$ [N]
< 750	5850	2925	8650	4325	10500	5250	12250	6125	15000	7500	19000	9500
> 750	4876	2438	7208	3604	8750	4375	10208	5104	12500	6250	15830	7915

Gearbox size	D [mm]	IEC motor	G [mm]	g [mm]	q [mm]	$q_1$ [mm]
230	300.00	132M	260.00	200.00	416.00	454.00
230	350.00	160	320.00	245.00	540.00	0.00
230	350.00	180	320.00	245.00	580.00	0.00
230	400.00	200	360.00	275.00	640.00	0.00

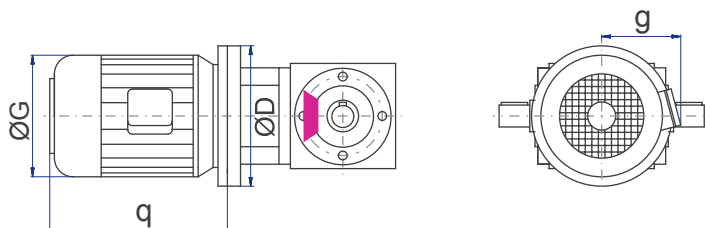
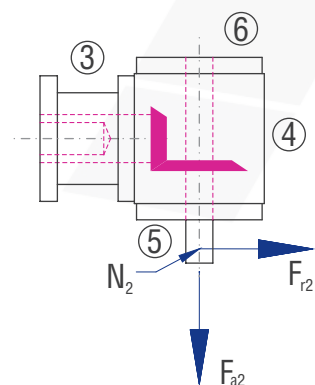

The mass inertia moment and the weight of the motor depend on the manufacturer. Please enquire the values of the overall system. For the dimensions of the bevel gearbox, please refer to the chapter 6.3 Standard bevel gearboxes

## Performance data

$P_1$ [kW]	$n_2$ [rpm]	$T_2$ [Nm]	$T_{2N}$ [Nm]	$T_{2MAX}$ [Nm]	$i$ [-]	IEC motor	Gearbox size	$P_{INT}$ [kW]
5.5	119	418.7	565	1000	6:1	160LA-8	230	34
7.5	160	425.3	540	1000	6:1	160MB-6	230	34
	144	472.5	770	1200	5:1	160LB-8	230	34
9	238	342.6	490	1000	6:1	132MC-4	230	34
15	1465	92.9	450	1090	1:1	160LA-4	230	34
	242	561.2	675	1300	4:1	180L-6	230	34
18.5	975	172.1	1050	2310	1:1	200LA-6	230	34
	490	342.5	366	1000	6:1	160L-2	230	34
	325	516.4	635	1300	3:1	200LA-6	230	34
	294	570.9	635	1200	5:1	180M-4	230	34
22	1470	135.8	450	1090	1:1	180L-4	230	34
	590	338.3	510	1200	5:1	180M-2	230	34
	367	543.1	600	1300	4:1	180L-4	230	34

## 10.3.13 Type VLM 260 – Type VL with motor (gearbox motor)

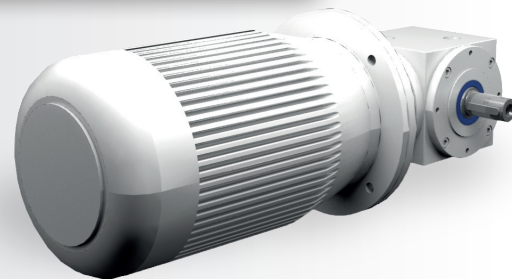

### Characteristics

Characteristic	Standard	Option
Toothing	Bevel gear, spiral-toothed	See chapter 6.2.1
Gear ratio	3:1 to 6:1	
Housing / Flanges	Grey cast iron	
Threaded mounting hole	On all housing surfaces without flange and on all flanges.	See chapter 6.2.3
Shaft	Material 1 C45, shaft ends greased Fit with ISO 6 tolerance with parallel keyway: according to DIN 6885 Sheet 1	See chapter 4.6.2
Hollow shaft	Material 1 C45, shafts greased Fit with ISO 7 tolerance with parallel keyway: according to DIN 6885 Sheet 1	See chapter 4.6.3
Radial shaft seal ring	NBR, form A	See chapter 4.8
Ambient temperature	-10°C to +90°C. The values of the performance tables are valid for +20°C	See chapter 4.9.3
Cumferential backlash	< 30 arcmin	See chapter 6.2.10
Protection class	IP 54	See chapter 4.5
Corrosion protection	Prime coat; layer thickness > 40 µm	See chapter 4.4.1
Bearing life L10h	more than 15,000h	See chapter 4.9.1
Oil change intervals	Not required if the oil temperature is kept < 90°C The lifetime of the bearings can be increased by the factor 1.5 if the oil is changed after the first 500 service hours and then every 5000 service hours.	See chapter 6.2.8
Lubricants	Synthetic lubricants	See chapter 6.2.8
Motor	IEC standard motor in the prescribed efficiency class	

### Permissible radial force $F_{r2}$ and axial force $F_{a2}$ on shaft $N_2$

$n_1$ [rpm]	3000		1000		500		250		100		50	
$T_2$ [Nm]	$F_r$ [N]	$F_a$ [N]	$F_r$ [N]	$F_a$ [N]	$F_r$ [N]	$F_a$ [N]	$F_r$ [N]	$F_a$ [N]	$F_r$ [N]	$F_a$ [N]	$F_r$ [N]	$F_a$ [N]
< 950	8500	4250	13000	6500	16000	8000	18000	9000	22000	11000	28000	14000
> 950	7080	3540	10830	5415	13330	6665	15000	7500	18330	9165	23330	11665

Gearbox size	D [mm]	IEC motor	G [mm]	g [mm]	q [mm]	$q_1$ [mm]
260	350.00	160	320.00	245.00	540.00	0.00
260	350.00	180	320.00	245.00	580.00	0.00
260	400.00	200	360.00	275.00	640.00	0.00

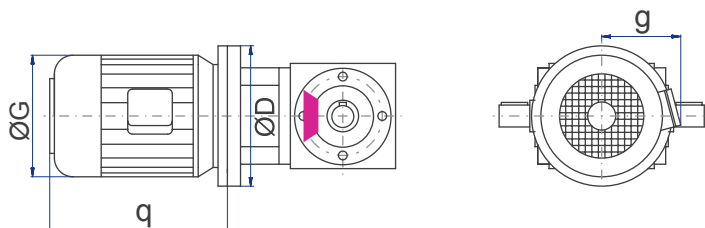
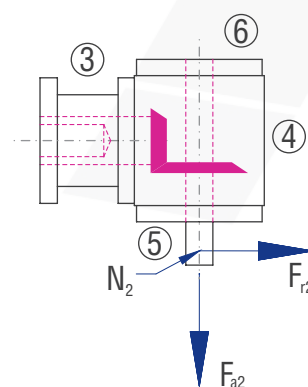

The mass inertia moment and the weight of the motor depend on the manufacturer. Please enquire the values of the overall system. For the dimensions of the bevel gearbox, please refer to the chapter 6.3 Standard bevel gearboxes



## Performance data

P <sub>1</sub> [kW]	n <sub>2</sub> [rpm]	T <sub>2</sub> [Nm]	T <sub>2N</sub> [Nm]	T <sub>2MAX</sub> [Nm]	i [-]	IEC motor	Gearbox size	P <sub>1NT</sub> [kW]
7.5	144	472.5	1100	1910	5:1	160LB-8	260	42
11	192	519.8	990	1910	5:1	160LA-6	260	42
	182	546.8	1100	1940	4:1	180L-8	260	42
	146	683.5	1100	1910	5:1	180L-8	260	42
	293	464.5	880	1910	5:1	160LA-4	260	42
15	242	561.2	1050	1940	4:1	180L-6	260	42
	194	701.5	990	1910	5:1	180L-6	260	42
	146	932.1	1100	1910	5:1	200LB-8	260	42
	975	172.1	1050	2310	1:1	200LA-6	260	42
18.5	650	258.2	1000	1000	1.5:1	200LA-6	260	42
	325	516.4	990	1940	3:1	200LA-6	260	42
	294	570.9	880	1910	5:1	180M-4	260	42
	243	690.7	1050	1940	4:1	200LA-6	260	42
	195	860.7	990	1910	5:1	200LA-6	260	42
	650	307.1	1000	1000	1.5:1	200LB-6	260	42
22	487	409.8	1050	1200	2:1	200LB-6	260	42
	367	543.9	900	1940	4:1	180L-4	260	42
	294	678.9	880	1910	5:1	180L-4	260	42
	243	821.4	1050	1940	4:1	200LB-6	260	42
	243	821.4	1050	1940	4:1	200LB-6	260	42

# 10.4 Type SLM – Type SL with motor (gearbox motor)

## 10.4.1 Features

Nominal gear ratios:  $i = 5:1$  to  $83:1$   
 Maximum output torque: 10,500 Nm  
 8 sizes, centre-to-centre distance of 040 to 200 mm  
 Low-backlash construction < 6 angular minutes possible  
 With mounted IEC standard motor  
 Positive coupling between motor and gearbox  
 Housing made of grey cast iron

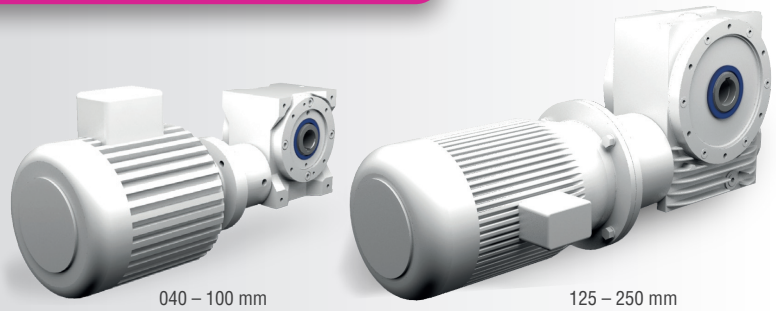

## 10.4.2 Models

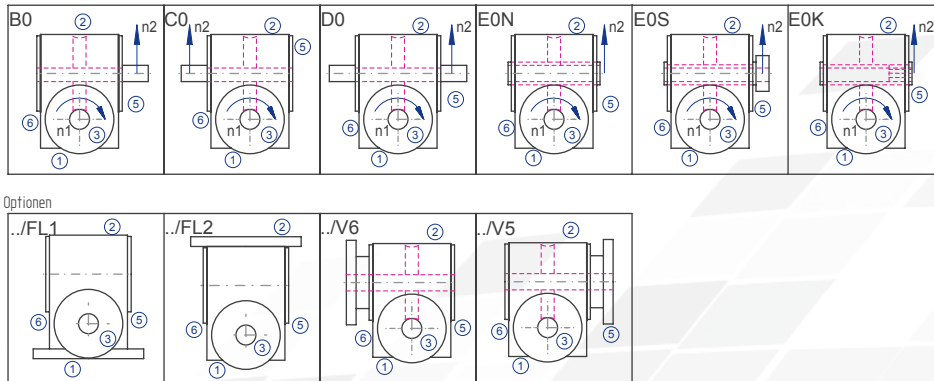

Figure 10.4.2-1; Models

## 10.4.3 Gearbox sides

The example shows the Model B0 without motor

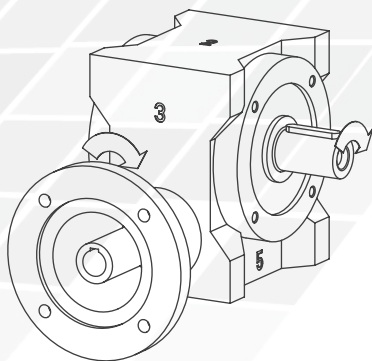

Figure 10.4.3-1; Gearbox sides

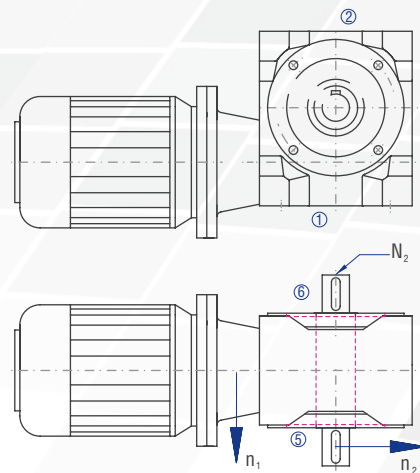

Figure 10.4.3-2; Shaft designations

## 10.4.4 Order code

The order code reflects the customer specifications. Example:

Type	Size	Gear ratio	Model	Fixing side	Installation position	Speed $n_2$	Design
SLM	063	10:1	B0-	1.	1-	150	/0000
<b>Description</b>	Centre-to-centre distance Table 10.4.5-1	Table 10.4.5-1	Figure 10.4.2-1; Models	Gearbox side on which fixing is made Table 9.2.3-1; Figure 4.3.1-1 Gearbox sides	Side directed downwards; Figure 4.3.1-1 Gearbox sides	Slowly rotating shaft; Table 10.4.5-1	Standard
	DS 090	-4	/00	-5			
	Motor type	Number of poles	Additional version	Connection box to the side			

Motor type: DS 090; three-phase motor  
 Number of poles: 4; speed of approx. 1500 rpm (6000/4) at 50 Hz  
 Connection box: 5; the motor connection box points to the gearbox side 5

## 10.4.5 Overview of performance data

P1 [kW]	n <sub>2</sub> [rpm]	T <sub>2</sub> [Nm]	T <sub>2N</sub> [Nm]	T <sub>2 max</sub> [Nm]	Gearbox size	i [-]	IEC motor	
0.18	277	5.8	41	73	040	4.83:1	063B-4	
	275	5.7	39	77	040	9.75:1	063A-2	
	206	7.3	31	59	040	13:1	063A-2	
	185	8.5	45	83	040	7.25:1	063B-4	
	137	11.3	43	77	040	9.75:1	063B-4	
	123	12.6	51	83	040	7.25:1	071A-6	
	103	14.5	32	59	040	13:1	063B-4	
	92	15.7	48	97	040	14.5:1	063B-4	
	69	20.4	50	90	040	19.5:1	063B-4	
	61	23.1	55	97	040	14.5:1	071A-6	
	52	25.8	38	77	040	26:1	063B-4	
	46	27.3	50	107	040	29:1	063B-4	
	34	35.4	56	99	040	39:1	063B-4	
	34	38.4	40	77	040	26:1	071A-6	
	31	38.8	57	107	040	29:1	071A-6	
	26	43.0	46	87	040	52:1	063B-4	
	23	50.1	63	99	040	39:1	071A-6	
	22	46.1	48	72	040	63:1	063B-4	
	18	65.9	137	197	050	38:1	080A-8	
	17	67.7	88	145	050	51:1	071A-6	
	16	60.2	63	112	050	83:1	063B-4	
	14	73.7	109	120	050	62:1	071A-6	
	13	84.6	91	145	050	51:1	080A-8	
	11	89.1	112	120	050	62:1	080A-8	
	0.25	372	5.9	36	83	040	7.25:1	063B-2
		280	8.0	41	73	040	4.83:1	071A-4
277		7.8	39	77	040	9.75:1	063B-2	
208		10.1	31	59	040	13:1	063B-2	
186		11.7	45	83	040	7.25:1	071A-4	
139		15.5	43	77	040	9.75:1	071A-4	
123		17.5	51	83	040	7.25:1	071B-6	
104		20.0	32	59	040	13:1	071A-4	
93		21.6	48	97	040	14.5:1	071A-4	
70		28.0	50	90	040	19.5:1	071A-4	
61		32.1	55	97	040	14.5:1	071B-6	
52		35.8	38	77	040	26:1	071A-4	
47		37.1	50	107	040	29:1	071A-4	
46		41.5	53	90	040	19.5:1	071A-4	
35		47.8	56	99	040	39:1	071A-4	
31		53.9	57	107	040	29:1	071B-6	
26		63.4	85	145	050	51:1	071A-4	
23		74.7	144	219	050	29:1	080B-8	
22		69.5	105	120	050	62:1	071A-4	
18		91.5	137	197	050	38:1	080B-8	
17		100.0	200	310	063	51:1	071B-6	
16		94.0	152	246	063	82:1	071A-4	
15		104.0	202	240	063	61:1	071B-6	
14		102.0	109	120	050	62:1	071B-6	
13		125.0	207	310	063	51:1	080B-8	
11		128.0	152	246	063	82:1	071B-6	
11	135.0	221	240	063	61:1	080B-8		
8	176.0	304	510	080	82:1	080B-8		

P1 [kW]	n <sub>2</sub> [rpm]	T <sub>2</sub> [Nm]	T <sub>2N</sub> [Nm]	T <sub>2 max</sub> [Nm]	Gearbox size	i [-]	IEC motor
0.37	580	5.7	33	73	040	4.83:1	071A-2
	386	8.4	36	83	040	7.25:1	071A-2
	288	11.2	39	77	040	9.75:1	071A-2
	280	11.9	41	73	040	4.83:1	071B-4
	216	14.4	31	59	040	13:1	071A-2
	186	17.3	45	83	040	7.25:1	071B-4
	139	22.9	43	77	040	9.75:1	071B-4
	124	26.2	117	167	050	7.25:1	080A-6
	104	29.6	32	59	040	13:1	071B-4
	93	31.9	48	97	040	14.5:1	071B-4
	70	41.4	50	90	040	19.5:1	071B-4
	62	48.4	121	195	050	14.5:1	080A-6
	53	54.0	76	137	050	25.5:1	071B-4
	47	57.9	113	219	050	29:1	071B-4
	47	62.4	110	179	050	19:1	080A-6
	36	73.6	118	197	050	38:1	071B-4
	35	79.8	80	137	050	25.5:1	080A-6
	35	83.8	181	295	063	25.5:1	080A-6
	31	84.3	121	219	050	29:1	080A-6
	26	101.0	191	310	063	51:1	071B-4
	24	105.0	134	197	050	38:1	080A-6
	23	111.0	144	219	050	29:1	090S-8
	22	103.0	105	120	050	62:1	071B-4
	22	109.0	175	240	063	61:1	071B-4
	18	136.0	137	197	050	38:1	090S-8
	18	139.0	200	310	063	51:1	080A-6
17	150.0	264	360	063	39:1	090S-8	
16	139.0	152	246	063	82:1	071B-4	
15	153.0	202	240	063	61:1	080A-6	
13	185.0	207	310	063	51:1	090S-8	
11	196.0	304	510	080	82:1	080A-6	
11	199.0	221	240	063	61:1	090S-8	
8	261.0	304	510	080	82:1	090S-8	
0.55	582	8.5	33	73	040	4.83:1	071B-2
	388	12.5	36	83	040	7.25:1	071B-2
	289	16.5	39	77	040	9.75:1	071B-2
	282	17.7	96	150	050	4.83:1	080A-4
	216	21.4	31	59	040	13:1	071B-2
	188	26.0	104	167	050	7.25:1	080A-4
	143	33.8	91	152	050	9.5:1	080A-4
	124	39.0	117	167	050	7.25:1	080B-6
	107	43.7	59	100	050	12.75:1	080A-4
	94	48.6	106	195	050	14.5:1	080A-4
	72	62.0	106	179	050	19:1	080A-4
	62	72.0	121	195	050	14.5:1	080B-6
	53	84.2	173	295	063	25.5:1	080A-4
	47	86.1	113	219	050	29:1	080A-4
	36	109.0	118	197	050	38:1	080A-4
	35	125.0	181	295	063	25.5:1	080B-6
	31	131.0	237	437	063	29:1	080B-6
	27	144.0	191	310	063	51:1	080A-4
	24	164.0	268	437	063	29:1	090L-8
	23	171.0	237	360	063	39:1	080B-6
	22	162.0	175	240	063	61:1	080A-4
	18	210.0	264	360	063	39:1	090L-8
	17	201.0	304	510	080	82:1	080A-4
	17	229.0	284	480	080	53:1	080B-6
	15	238.0	325	480	080	62:1	080B-6
	13	287.0	294	480	080	53:1	090L-8
11	291.0	304	510	080	82:1	080B-6	
11	310.0	352	480	080	62:1	090L-8	

Table 10.4.5-1

If the fed motor output exceeds the thermal limit rating of the gearbox, additional cooling measures will be needed.





# 10.4 Type SLM – Type SL with motor (gearbox motor)

P1 [kW]	n <sub>2</sub> [rpm]	T <sub>2</sub> [Nm]	T <sub>2N</sub> [Nm]	T <sub>2 max</sub> [Nm]	Gearbox size	i [-]	IEC motor
9.00	582	142.0	450	1190	100	5:1	132MA-2
	401	204.0	783	2250	125	7.25:1	132MA-2
	388	208.0	513	1360	100	7.5:1	132MA-2
	296	279.0	895	2250	125	4.83:1	132MC-4
	291	278.0	555	1090	100	10:1	132MA-2
	291	278.0	850	2250	125	10:1	132MA-2
	224	353.0	427	736	100	13:1	132MA-2
	224	357.0	700	1190	125	13:1	132MA-2
	197	415.0	986	2250	125	7.25:1	132MC-4
	143	565.0	1069	2250	125	10:1	132MC-4
	110	719.0	763	1190	125	13:1	132MC-4
	95	832.0	1970	4550	160	15:1	132MC-4
	72	1062.0	1183	2392	125	20:1	132MC-4
	72	1074.0	2158	5050	160	20:1	132MC-4
	53	1443.0	2124	3345	160	27:1	132MC-4
	48	1504.0	2170	4500	160	30:1	132MC-4
	48	1540.0	3900	10500	200	30:1	132MC-4
	36	1982.0	2267	5120	160	40:1	132MC-4
	36	2006.0	3860	9800	200	40:1	132MC-4
	27	2610.0	3870	7500	200	53:1	132MC-4
17	3797.0	3797	6800	200	83:1	132MC-4	
11.00	602	168.0	626	2250	125	4.83:1	160MA-2
	401	249.0	783	2250	125	7.25:1	160MA-2
	303	333.0	895	2250	125	4.83:1	160MB-4
	291	339.0	850	2250	125	10:1	160MA-2
	224	436.0	700	1190	125	13:1	160MA-2
	202	494.0	986	2250	125	7.25:1	160MB-4
	147	672.0	1069	2250	125	10:1	160MB-4
	147	679.0	1951	4780	160	10:1	160MB-4
	132	756.0	1127	2250	125	7.25:1	160LA-6
	128	788.0	2051	4450	160	7.5:1	160LA-6
	109	906.0	1600	2410	160	13.5:1	160MB-4
	98	986.0	1970	4550	160	15:1	160MB-4
	73	1295.0	2158	5050	160	20:1	160MB-4
	64	1510.0	2386	4550	160	15:1	160LA-6
	54	1731.0	2124	3345	160	27:1	160MB-4
	49	1801.0	2170	4500	160	30:1	160MB-4
	49	1844.0	3900	10500	200	30:1	160MB-4
	48	1970.0	2467	5050	160	20:1	160LA-6
	48	2014.0	4241	10000	200	20:1	160LA-6
	37	2385.0	3860	9800	200	40:1	160MB-4
36	2626.0	4190	6790	200	26.5:1	160LA-6	
32	2823.0	4862	10500	200	30:1	160LA-6	
28	3077.0	3870	7500	200	53:1	160MB-4	
24	3720.0	4761	9800	200	40:1	160LA-6	
24	3764.0	5790	10500	200	30:1	180L-8	
18	4902.0	5620	9800	200	40:1	180L-8	

Table 10.4.5-1

P1 [kW]	n <sub>2</sub> [rpm]	T <sub>2</sub> [Nm]	T <sub>2N</sub> [Nm]	T <sub>2 max</sub> [Nm]	Gearbox size	i [-]	IEC motor	
15.00	607	227.0	626	2250	125	4.83:1	160MB-2	
	404	339.0	783	2250	125	7.25:1	160MB-2	
	391	348.0	996	4450	160	7.5:1	160MB-2	
	303	454.0	985	2250	125	4.83:1	160LA-4	
	293	460.0	850	2250	125	10:1	160MB-2	
	293	474.0	1640	4450	160	5:1	160LA-4	
	225	592.0	700	1190	125	13:1	160MB-2	
	217	621.0	1466	2410	160	13.5:1	160MB-2	
	202	674.0	986	2250	125	7.25:1	160LA-4	
	195	698.0	1793	4450	160	7.5:1	160LA-4	
	147	926.0	1951	4780	160	10:1	160LA-4	
	129	1066.0	2051	4450	160	7.5:1	180L-6	
	109	1235.0	1600	2410	160	13.5:1	160LA-4	
	98	1345.0	1970	4550	160	15:1	160LA-4	
	98	1345.0	3450	10500	200	15:1	160LA-4	
	73	1766.0	2158	5050	160	20:1	160LA-4	
	73	1786.0	3430	10000	200	20:1	160LA-4	
	65	2028.0	2386	4550	160	15:1	180L-6	
	65	2050.0	4308	10500	200	15:1	180L-6	
	18.50	55	2344.0	3612	6790	200	26.5:1	160LA-4
49		2514.0	3900	10500	200	30:1	160LA-4	
49		2690.0	4241	10000	200	20:1	180L-6	
37		3252.0	3860	9800	200	40:1	160LA-4	
37		3485.0	4190	6790	200	26.5:1	180L-6	
32		3850.0	4862	10500	200	30:1	180L-6	
24		5133.0	5790	10500	200	30:1	200LB-8	
392		428.0	996	4450	160	7.5:1	160L-2	
294		583.0	1640	4450	160	5:1	180M-4	
218		762.0	1466	2410	160	13.5:1	160L-2	
196		856.0	1793	4450	160	7.5:1	180M-4	
147		1142.0	1951	4780	160	10:1	180M-4	
130		1305.0	3485	9800	200	7.5:1	200LA-6	
111		1512.0	3265	5396	200	13.25:1	180M-4	
109		1524.0	1600	2410	160	13.5:1	180M-4	
98		1659.0	1970	4550	160	15:1	180M-4	
98		1659.0	3450	10500	200	15:1	180M-4	
74		2149.0	2158	5050	160	20:1	180M-4	
74		2173.0	3430	10000	200	20:1	180M-4	
65		2528.0	4308	10500	200	15:1	200LA-6	
55	2891.0	3612	6790	200	26.5:1	180M-4		
49	3101.0	3900	10500	200	30:1	180M-4		
49	3317.0	4241	10000	200	20:1	200LA-6		
33	4604.0	4862	10500	200	30:1	200LA-6		
22.00	294	693.0	1640	4450	160	5:1	180L-4	
	196	1018.0	1793	4450	160	7.5:1	180L-4	
	196	1029.0	2869	9800	200	7.5:1	180L-4	
	147	1358.0	1951	4780	160	10:1	180L-4	
	147	1358.0	3076	9277	200	10:1	180L-4	
	130	1552.0	3485	9800	200	7.5:1	200LB-6	
	111	1798.0	3265	5396	200	13.25:1	180L-4	
	98	1972.0	3450	10500	200	15:1	180L-4	
	74	2584.0	3430	10000	200	20:1	180L-4	
	65	3006.0	4308	10500	200	15:1	200LB-6	
	55	3438.0	3612	6790	200	26.5:1	180L-4	
	49	3688.0	3900	10500	200	30:1	180L-4	
	49	3945.0	4241	10000	200	20:1	200LB-6	
	30.00	294	945.0	2600	8500	200	5:1	200LB-4
		196	1403.0	2867	9800	200	7.5:1	200LB-4
		147	1852.0	3076	9276	200	10:1	200LB-4
		111	2452.0	3265	5396	200	13.25:1	200LB-4
		98	2690.0	3450	10500	200	15:1	200LB-4



## 10.4.6 Type SLM 040 – Type SL with motor (gearbox motor)

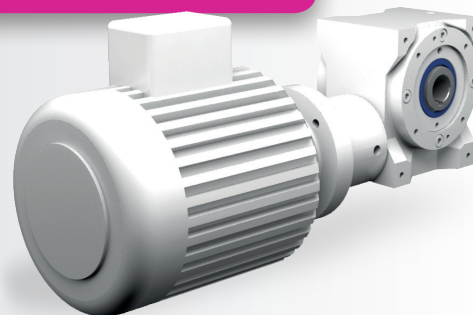

### Characteristics

Characteristic	Standard	Option
<b>Toothing</b>	Hardened and ground worm shaft / bronze worm gear	See chapter 9.2.1
<b>Gear ratio</b>	5:1 to 83:1	
<b>Housing / Flanges</b>	Grey cast iron	
<b>Threaded mounting hole</b>	On gearbox side 1 and on the flanges	See chapter 9.2.3
<b>Shaft</b>	Material 1 C45, shaft ends greased Fit with ISO j6 tolerance with parallel keyway: according to DIN 6885 Sheet 1	See chapter 4.6.2
<b>Hollow shaft</b>	Material 1 C45, shafts greased Fit with ISO H7 tolerance with parallel keyway: according to DIN 6885 Sheet 1	See chapter 4.6.3
<b>Radial shaft seal ring</b>	NBR, form A	See chapter 4.8
<b>Ambient temperature</b>	-10°C to +90°C. The values of the performance tables are valid for +20°C	See chapter 4.9.3
<b>Circumferential backlash</b>	< 30 arcmin	See chapter 9.2.10
<b>Protection class</b>	IP 54	See chapter 4.5
<b>Corrosion protection</b>	Prime coat; layer thickness > 40 µm	See chapter 4.4.1
<b>Bearing life L10h</b>	more than 15,000h	See chapter 4.9.1
<b>Oil change intervals</b>	Not required if the oil temperature is kept < 90°C The lifetime of the bearings can be increased by the factor 1.5 if the oil is changed after the first 500 service hours and then every 5000 service hours.	See chapter 9.2.8
<b>Lubricants</b>	Synthetic lubricants	See chapter 9.2.8
<b>Motor</b>	IEC standard motor in the prescribed efficiency class	

For the dimensions of the worm gearbox, please refer to chapter 9.3.6 Standard worm gearboxes, page 187



## Performance data

P <sub>1</sub> [kW]	n <sub>2</sub> [rpm]	T <sub>2</sub> [Nm]	T <sub>2N</sub> [Nm]	T <sub>2 max</sub> [Nm]	Gearbox size	i [-]	IEC motor
0.18	277	5.8	41	73	040	4.83:1	063B-4
	275	5.7	39	77	040	9.75:1	063A-2
	206	7.3	31	59	040	13:1	063A-2
	185	8.5	45	83	040	7.25:1	063B-4
	137	11.3	43	77	040	9.75:1	063B-4
	123	12.6	51	83	040	7.25:1	071A-6
	103	14.5	32	59	040	13:1	063B-4
	92	15.7	48	97	040	14.5:1	063B-4
	69	20.4	50	90	040	19.5:1	063B-4
	61	23.1	55	97	040	14.5:1	071A-6
	52	25.8	38	77	040	26:1	063B-4
	46	27.3	50	107	040	29:1	063B-4
	34	35.4	56	99	040	39:1	063B-4
	34	38.4	40	77	040	26:1	071A-6
	31	38.8	57	107	040	29:1	071A-6
	26	43.0	46	87	040	52:1	063B-4
	23	50.1	63	99	040	39:1	071A-6
	22	46.1	48	72	040	63:1	063B-4
0.25	372	5.9	36	83	040	7.25:1	063B-2
	280	8.0	41	73	040	4.83:1	071A-4
	277	7.8	39	77	040	9.75:1	063B-2
	208	10.1	31	59	040	13:1	063B-2
	186	11.7	45	83	040	7.25:1	071A-4
	139	15.5	43	77	040	9.75:1	071A-4
	123	17.5	51	83	040	7.25:1	071B-6
	104	20.0	32	59	040	13:1	071A-4
	93	21.6	48	97	040	14.5:1	071A-4
	70	28.0	50	90	040	19.5:1	071A-4

P <sub>1</sub> [kW]	n <sub>2</sub> [rpm]	T <sub>2</sub> [Nm]	T <sub>2N</sub> [Nm]	T <sub>2 max</sub> [Nm]	Gearbox size	i [-]	IEC motor
0.25	61	32.1	55	97	040	14.5:1	071B-6
	52	35.8	38	77	040	26:1	071A-4
	47	37.1	50	107	040	29:1	071A-4
	46	41.5	53	90	040	19.5:1	071A-4
	35	47.8	56	99	040	39:1	071A-4
	31	53.9	57	107	040	29:1	071B-6
0.37	580	5.7	33	73	040	4.83:1	071A-2
	386	8.4	36	83	040	7.25:1	071A-2
	288	11.2	39	77	040	9.75:1	071A-2
	280	11.9	41	73	040	4.83:1	071B-4
	216	14.4	31	59	040	13:1	071A-2
	186	17.3	45	83	040	7.25:1	071B-4
	139	22.9	43	77	040	9.75:1	071B-4
	104	29.6	32	59	040	13:1	071B-4
0.55	93	31.9	48	97	040	14.5:1	071B-4
	70	41.4	50	90	040	19.5:1	071B-4
	582	8.5	33	73	040	4.83:1	071B-2
	388	12.5	36	83	040	7.25:1	071B-2
	289	16.5	39	77	040	9.75:1	071B-2
216	21.4	31	59	040	13:1	071B-2	

## Permissible radial force F<sub>r2</sub> and axial force F<sub>a2</sub> on shaft N<sub>2</sub>

n <sub>2</sub> [rpm]	200		125		75		50		30		10	
T <sub>2</sub> [Nm]	F <sub>r</sub> [N]	F <sub>a</sub> [N]	F <sub>r</sub> [N]	F <sub>a</sub> [N]	F <sub>r</sub> [N]	F <sub>a</sub> [N]	F <sub>r</sub> [N]	F <sub>a</sub> [N]	F <sub>r</sub> [N]	F <sub>a</sub> [N]	F <sub>r</sub> [N]	F <sub>a</sub> [N]
< 80	970	485	1250	625	1380	690	1600	800	1800	900	2500	1250

The mass inertia moment and the weight of the motor depend on the manufacturer. Please enquire the values of the overall system. For the dimensions of the worm gearbox, please refer to chapter 8.3 Worm gearboxes

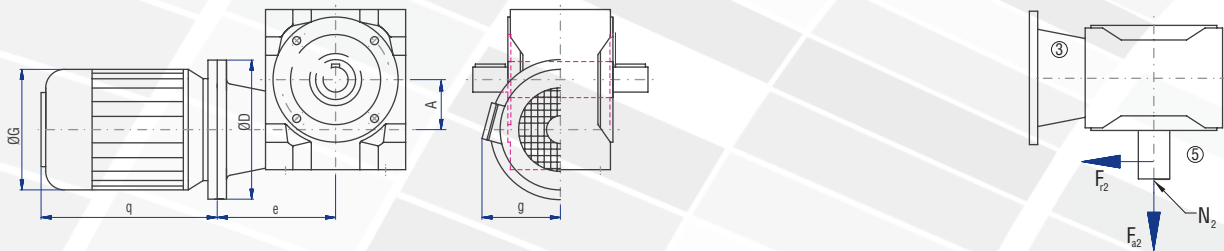

IEC motor	D [mm]	G [mm]	g [mm]	q [mm]	q <sub>1</sub> [mm]	e [mm]	A [mm]
063	120	125	95	189	211	121	40
071	105	148	115	208	228	121	40

The value q<sub>1</sub> applies to braking motors

## 10.4.7 Type SLM 050 – Type SL with motor (gearbox motor)

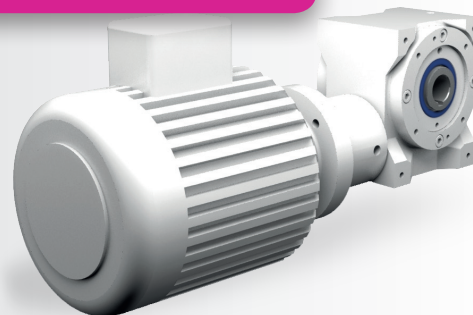

### Characteristics

Characteristic	Standard	Option
<b>Toothing</b>	Hardened and ground worm shaft / bronze worm gear	See chapter 9.2.1
<b>Gear ratio</b>	5:1 to 83:1	
<b>Housing / Flanges</b>	Grey cast iron	
<b>Threaded mounting hole</b>	On gearbox side 1 and on the flanges	See chapter 9.2.3
<b>Shaft</b>	Material 1 C45, shaft ends greased Fit with ISO j6 tolerance with parallel keyway: according to DIN 6885 Sheet 1	See chapter 4.6.2
<b>Hollow shaft</b>	Material 1 C45, shafts greased Fit with ISO H7 tolerance with parallel keyway: according to DIN 6885 Sheet 1	See chapter 4.6.3
<b>Radial shaft seal ring</b>	NBR, form A	See chapter 4.8
<b>Ambient temperature</b>	-10°C to +90°C. The values of the performance tables are valid for +20°C	See chapter 4.9.3
<b>Circumferential backlash</b>	< 30 arcmin	See chapter 9.2.10
<b>Protection classes</b>	IP 54	See chapter 4.5
<b>Corrosion protection</b>	Prime coat; layer thickness > 40 µm	See chapter 4.4.1
<b>Bearing life L10h</b>	more than 15,000h	See chapter 4.9.1
<b>Oil change intervals</b>	Not required if the oil temperature is kept < 90°C The lifetime of the bearings can be increased by the factor 1.5 if the oil is changed after the first 500 service hours and then every 5000 service hours.	See chapter 9.2.8
<b>Lubricants</b>	Synthetic lubricants	See chapter 9.2.8
<b>Motor</b>	IEC standard motor in the prescribed efficiency class	

For the dimensions of the worm gearbox, please refer to chapter 9.3.7 Standard worm gearboxes, page 191

## Performance data

P <sub>1</sub> [kW]	n <sub>2</sub> [rpm]	T <sub>2</sub> [Nm]	T <sub>2N</sub> [Nm]	T <sub>2 max</sub> [Nm]	Gearbox size	i [-]	IEC motor
0.18	18	65.9	137	197	050	38:1	080A-8
	17	67.7	88	145	050	51:1	071A-6
	16	60.2	63	112	050	83:1	063B-4
	14	73.7	109	120	050	62:1	071A-6
	13	84.6	91	145	050	51:1	080A-8
	11	89.1	112	120	050	62:1	080A-8
0.25	26	63.4	85	145	050	51:1	071A-4
	23	74.7	144	219	050	29:1	080B-8
	22	69.5	105	120	050	62:1	071A-4
	18	91.5	137	197	050	38:1	080B-8
	14	102.0	109	120	050	62:1	071B-6
0.37	124	26.2	117	167	050	7.25:1	080A-6
	62	48.4	121	195	050	14.5:1	080A-6
	53	54.0	76	137	050	25.5:1	071B-4
	47	57.9	113	219	050	29:1	071B-4
	47	62.4	110	179	050	19:1	080A-6
	36	73.6	118	197	050	38:1	071B-4
	35	79.8	80	137	050	25.5:1	080A-6
	31	84.3	121	219	050	29:1	080A-6
	24	105.0	134	197	050	38:1	080A-6
	23	111.0	144	219	050	29:1	090S-8
	22	103.0	105	120	050	62:1	071B-4
	18	136.0	137	197	050	38:1	090S-8
	0.55	282	17.7	96	150	050	4.83:1
188		26.0	104	167	050	7.25:1	080A-4
143		33.8	91	152	050	9.5:1	080A-4
124		39.0	117	167	050	7.25:1	080B-6
107		43.7	59	100	050	12.75:1	080A-4
94		48.6	106	195	050	14.5:1	080A-4
72		62.0	106	179	050	19:1	080A-4
62		72.0	121	195	050	14.5:1	080B-6
47		86.1	113	219	050	29:1	080A-4
36		109.0	118	197	050	38:1	080A-4

P <sub>1</sub> [kW]	n <sub>2</sub> [rpm]	T <sub>2</sub> [Nm]	T <sub>2N</sub> [Nm]	T <sub>2 max</sub> [Nm]	Gearbox size	i [-]	IEC motor
0.75	584	11.8	70	150	050	4.83:1	080A-2
	389	17.3	74	167	050	7.25:1	080A-2
	297	22.4	85	152	050	9.5:1	080A-2
	282	24.1	96	150	050	4.83:1	080B-4
	221	29.2	55	100	050	12.75:1	080A-2
	188	35.4	104	167	050	7.25:1	080B-4
	143	46.1	91	152	050	9.5:1	080B-4
	126	52.3	117	167	050	7.25:1	090S-6
	94	66.3	106	195	050	14.5:1	080B-4
	72	84.6	106	179	050	19:1	080B-4
1.10	63	96.6	121	195	050	14.5:1	090S-6
	584	17.3	70	150	050	4.83:1	080B-2
	389	25.4	74	167	050	7.25:1	080B-2
	297	32.9	85	152	050	9.5:1	080B-2
	286	34.9	96	150	050	4.83:1	090S-4
	221	42.8	55	100	050	12.75:1	080B-2
	190	51.4	104	167	050	7.25:1	090S-4
	145	66.7	91	152	050	9.5:1	090S-4
	126	76.7	117	167	050	7.25:1	090L-6
	1.50	588	23.4	70	150	050	4.83:1
392		34.4	74	167	050	7.25:1	090S-2
299		44.6	85	152	050	9.5:1	090S-2
286		47.6	96	150	050	4.83:1	090L-4
190		70.1	104	167	050	7.25:1	090L-4
145		90.9	91	152	050	9.5:1	090L-4
2.20	588	34.3	70	150	050	4.83:1	090L-2
	392	50.4	74	167	050	7.25:1	090L-2
	299	65.3	85	152	050	9.5:1	090L-2

## Permissible radial force F<sub>r2</sub> and axial force F<sub>a2</sub> on shaft N<sub>2</sub>

n <sub>2</sub> [rpm]	200		125		75		50		30		10		
	T <sub>2</sub> [Nm]	F <sub>r</sub> [N]	F <sub>a</sub> [N]	F <sub>r</sub> [N]	F <sub>a</sub> [N]	F <sub>r</sub> [N]	F <sub>a</sub> [N]	F <sub>r</sub> [N]	F <sub>a</sub> [N]	F <sub>r</sub> [N]	F <sub>a</sub> [N]		
< 120		2000	1000	2400	1200	2850	1425	3350	1675	4000	2000	4800	2400
> 120		1540	770	1850	925	2190	1095	2580	1290	3080	1540	3700	1850

The mass inertia moment and the weight of the motor depend on the manufacturer. Please enquire the values of the overall system. For the dimensions of the worm gearbox, please refer to chapter 8.3 Worm gearboxes

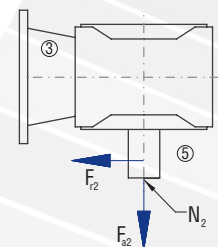
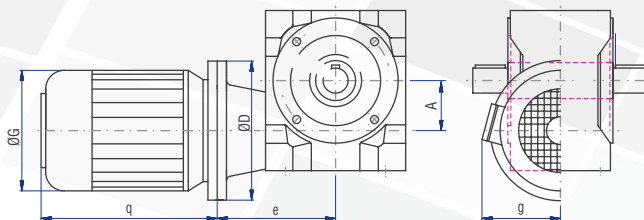

IEC motor	D [mm]	G [mm]	g [mm]	q [mm]	q <sub>1</sub> [mm]	e [mm]	A [mm]
063	120	125	95	189	211	150	50
071	140	148	115	208	228	121	50
080	120	170	126	234	245	150	50
90L	140	185	142	272	298	121	50
90S	140	185	142	247	273	121	50

The value q<sub>1</sub> applies to braking motors

## 10.4.8 Type SLM 063 – Type SL with motor (gearbox motor)

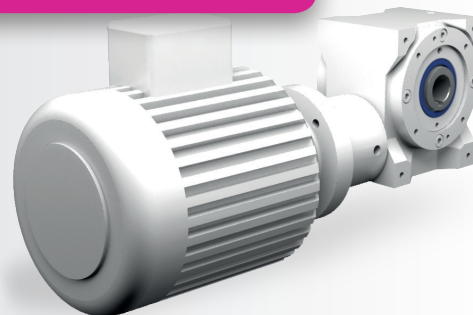

### Characteristics

Characteristic	Standard	Option
<b>Toothing</b>	Hardened and ground worm shaft / bronze worm gear	See chapter 9.2.1
<b>Gear ratio</b>	5:1 to 83:1	
<b>Housing / Flanges</b>	Grey cast iron	
<b>Threaded mounting hole</b>	On gearbox side 1 and on the flanges	See chapter 9.2.3
<b>Shaft</b>	Material 1 C45, shaft ends greased Fit with ISO j6 tolerance with parallel keyway: according to DIN 6885 Sheet 1	See chapter 4.6.2
<b>Hollow shaft</b>	Material 1 C45, shafts greased Fit with ISO H7 tolerance with parallel keyway: according to DIN 6885 Sheet 1	See chapter 4.6.3
<b>Radial shaft seal ring</b>	NBR, form A	See chapter 4.8
<b>Ambient temperature</b>	-10°C to +90°C. The values of the performance tables are valid for +20°C	See chapter 4.9.3
<b>Circumferential backlash</b>	< 30 arcmin	See chapter 9.2.10
<b>Protection classes</b>	IP 54	See chapter 4.5
<b>Corrosion protection</b>	Prime coat; layer thickness > 40 µm	See chapter 4.4.1
<b>Bearing life L10h</b>	more than 15,000h	See chapter 4.9.1
<b>Oil change intervals</b>	Not required if the oil temperature is kept < 90°C The lifetime of the bearings can be increased by the factor 1.5 if the oil is changed after the first 500 service hours and then every 5000 service hours.	See chapter 9.2.8
<b>Lubricants</b>	Synthetic lubricants	See chapter 9.2.8
<b>Motor</b>	IEC standard motor in the prescribed efficiency class	

For the dimensions of the worm gearbox, please refer to chapter 9.3.8 Standard worm gearboxes, page 195

## Performance data

P <sub>1</sub> [kW]	n <sub>2</sub> [rpm]	T <sub>2</sub> [Nm]	T <sub>2N</sub> [Nm]	T <sub>2 max</sub> [Nm]	Gearbox size	i [-]	IEC motor
0.25	17	100.0	200	310	063	51:1	071B-6
	16	94.0	152	246	063	82:1	071A-4
	15	104.0	202	240	063	61:1	071B-6
	13	125.0	207	310	063	51:1	080B-8
	11	128.0	152	246	063	82:1	071B-6
	11	135.0	221	240	063	61:1	080B-8
0.37	35	83.8	181	295	063	25.5:1	080A-6
	26	101.0	191	310	063	51:1	071B-4
	22	109.0	175	240	063	61:1	071B-4
	18	139.0	200	310	063	51:1	080A-6
	17	150.0	264	360	063	39:1	090S-8
	16	139.0	152	246	063	82:1	071B-4
	15	153.0	202	240	063	61:1	080A-6
	13	185.0	207	310	063	51:1	090S-8
0.55	11	199.0	221	240	063	61:1	090S-8
	53	84.2	173	295	063	25.5:1	080A-4
	35	125.0	181	295	063	25.5:1	080B-6
	31	131.0	237	437	063	29:1	080B-6
	27	144.0	191	310	063	51:1	080A-4
	24	164.0	268	437	063	29:1	090L-8
	23	171.0	237	360	063	39:1	080B-6
	22	162.0	175	240	063	61:1	080A-4
18	210.0	264	360	063	39:1	090L-8	

P <sub>1</sub> [kW]	n <sub>2</sub> [rpm]	T <sub>2</sub> [Nm]	T <sub>2N</sub> [Nm]	T <sub>2 max</sub> [Nm]	Gearbox size	i [-]	IEC motor
0.75	53	115.0	173	295	063	25.5:1	080B-4
	47	122.0	204	437	063	29:1	080B-4
	47	131.0	212	355	063	19.5:1	090S-6
	36	165.0	181	295	063	25.5:1	090S-6
	35	158.0	207	348	063	39:1	080B-4
	31	178.0	237	437	063	29:1	090S-6
	24	224.0	268	437	063	29:1	100LA-8
	23	234.0	237	360	063	39:1	090S-6
1.10	108	89.5	135	222	063	12.75:1	090S-4
	95	98.4	183	395	063	14.5:1	090S-4
	71	130.0	186	355	063	19.5:1	090S-4
	63	145.0	213	395	063	14.5:1	090L-6
	54	165.0	173	295	063	25.5:1	090S-4
	48	175.0	204	437	063	29:1	090S-4
	47	192.0	212	355	063	19.5:1	090L-6
	223	59.7	125	222	063	12.75:1	090S-2
	142	93.8	170	306	063	9.75:1	090L-4
	127	105.0	179	334	063	7.25:1	100LA-6
1.50	108	122.0	135	222	063	12.75:1	090L-4
	95	134.0	183	395	063	14.5:1	090L-4
	71	178.0	186	355	063	19.5:1	090L-4
	63	198.0	213	395	063	14.5:1	100LA-6
	292	69.1	145	295	063	4.83:1	100LA-4
	223	87.6	125	222	063	12.75:1	090L-2
	194	102.0	157	334	063	7.25:1	100LA-4
	145	135.0	170	306	063	9.75:1	100LA-4
2.20	130	150.0	179	334	063	7.25:1	112M-6
	590	46.6	94	295	063	4.83:1	100L-2
	393	68.5	106	334	063	7.25:1	100L-2
	292	92.2	121	306	063	9.75:1	100L-2
	292	94.2	145	295	063	4.83:1	100LB-4
	224	119.0	125	222	063	12.75:1	100L-2
	194	139.0	157	334	063	7.25:1	100LB-4
	592	61.9	94	295	063	4.83:1	112M-2
3.00	394	91.1	106	334	063	7.25:1	112M-2
	294	125.0	145	295	063	4.83:1	112M-4
	592	61.9	94	295	063	4.83:1	112M-2

Gearbox motors

## Permissible radial force F<sub>r2</sub> and axial force F<sub>a2</sub> on shaft N<sub>2</sub>

n <sub>2</sub> [rpm]	200		125		75		50		30		10		
	T <sub>2</sub> [Nm]	F <sub>r</sub> [N]	F <sub>a</sub> [N]	F <sub>r</sub> [N]	F <sub>a</sub> [N]	F <sub>r</sub> [N]	F <sub>a</sub> [N]	F <sub>r</sub> [N]	F <sub>a</sub> [N]	F <sub>r</sub> [N]	F <sub>a</sub> [N]	F <sub>r</sub> [N]	F <sub>a</sub> [N]
< 220		2700	1350	3150	1575	3800	1900	4500	2250	5200	2600	5200	2600
> 220		2080	1040	2420	1210	2920	1460	3460	1730	4000	2000	4000	2000

The mass inertia moment and the weight of the motor depend on the manufacturer. Please enquire the values of the overall system. For the dimensions of the worm gearbox, please refer to chapter 8.3 Worm gearboxes

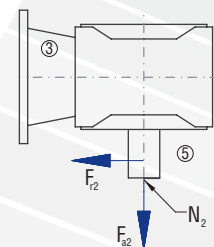
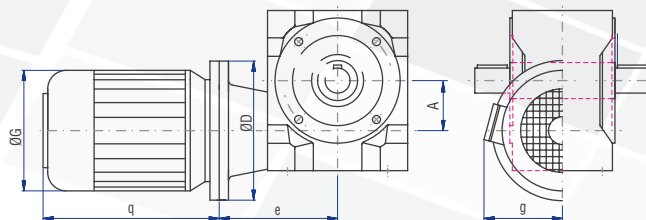

IEC motor	D [mm]	G [mm]	g [mm]	q [mm]	q <sub>1</sub> [mm]	e [mm]	A [mm]
071	160	148	115	208	228	163	63
080	160	170	126	234	245	163	63
90L	200	185	142	272	298	175	63
90S	200	185	142	247	273	175	63
100	200	210	155	301	348	175	63
112	200	210	155	301	348	175	63

The value q<sub>1</sub> applies to braking motors

## 10.4.9 Type SLM 080 – Type SL with motor (gearbox motor)

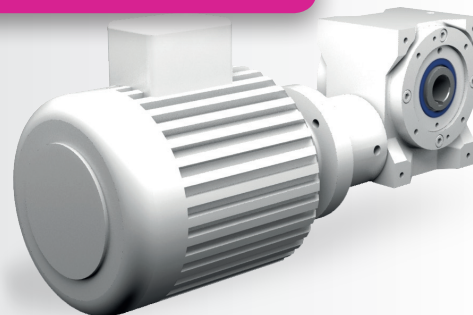

### Characteristics

Characteristic	Standard	Option
<b>Toothing</b>	Hardened and ground worm shaft / bronze worm gear	See chapter 9.2.1
<b>Gear ratio</b>	5:1 to 83:1	
<b>Housing / Flanges</b>	Grey cast iron	
<b>Threaded mounting hole</b>	On gearbox side 1 and on the flanges	See chapter 9.2.3
<b>Shaft</b>	Material 1 C45, shaft ends greased Fit with ISO j6 tolerance with parallel keyway: according to DIN 6885 Sheet 1	See chapter 4.6.2
<b>Hollow shaft</b>	Material 1 C45, shafts greased Fit with ISO H7 tolerance with parallel keyway: according to DIN 6885 Sheet 1	See chapter 4.6.3
<b>Radial shaft seal ring</b>	NBR, form A	See chapter 4.8
<b>Ambient temperature</b>	-10°C to +90°C. The values of the performance tables are valid for +20°C	See chapter 4.9.3
<b>Circumferential backlash</b>	< 30 arcmin	See chapter 9.2.10
<b>Protection classes</b>	IP 54	See chapter 4.5
<b>Corrosion protection</b>	Prime coat; layer thickness > 40 µm	See chapter 4.4.1
<b>Bearing life L10h</b>	more than 15,000h	See chapter 4.9.1
<b>Oil change intervals</b>	Not required if the oil temperature is kept < 90°C The lifetime of the bearings can be increased by the factor 1.5 if the oil is changed after the first 500 service hours and then every 5000 service hours.	See chapter 9.2.8
<b>Lubricants</b>	Synthetic lubricants	See chapter 9.2.8
<b>Motor</b>	IEC standard motor in the prescribed efficiency class	

For the dimensions of the worm gearbox, please refer to chapter 9.3.9 Standard worm gearboxes, page 199

## Performance data

P <sub>1</sub> [kW]	n <sub>2</sub> [rpm]	T <sub>2</sub> [Nm]	T <sub>2N</sub> [Nm]	T <sub>2 max</sub> [Nm]	Gearbox size	i [-]	IEC motor
0.25	8	176.0	304	510	080	82:1	080B-8
	11	196.0	304	510	080	82:1	080A-6
0.37	8	261.0	304	510	080	82:1	090S-8
	17	201.0	304	510	080	82:1	080A-4
0.55	17	229.0	284	480	080	53:1	080B-6
	15	238.0	325	480	080	62:1	080B-6
	13	287.0	294	480	080	53:1	090L-8
	11	291.0	304	510	080	82:1	080B-6
	11	310.0	352	480	080	62:1	090L-8
0.75	26	212.0	271	480	080	53:1	080B-4
	22	228.0	279	480	080	62:1	080B-4
	17	274.0	304	510	080	82:1	080B-4
	17	316.0	501	780	080	40:1	100LA-8
	15	325.0	325	480	080	62:1	090S-6
1.10	52	176.0	245	432	080	26.5:1	090S-4
	46	187.0	395	920	080	30:1	090S-4
	35	240.0	381	780	080	40:1	090S-4
	30	280.0	465	920	080	30:1	090L-6
	23	356.0	443	780	080	40:1	090L-6
	23	356.0	530	920	080	30:1	100LB-8
	17	464.0	501	780	080	40:1	100LB-8

P <sub>1</sub> [kW]	n <sub>2</sub> [rpm]	T <sub>2</sub> [Nm]	T <sub>2N</sub> [Nm]	T <sub>2 max</sub> [Nm]	Gearbox size	i [-]	IEC motor
1.50	52	240.0	245	432	080	26.5:1	090L-4
	46	255.0	395	920	080	30:1	090L-4
	46	274.0	399	725	080	20:1	100LA-6
	35	327.0	381	780	080	40:1	090L-4
	31	370.0	465	920	080	30:1	100LA-6
	23	486.0	530	920	080	30:1	112M-8
2.20	108	179.0	187	321	080	13:1	100LA-4
	94	203.0	352	826	080	15:1	100LA-4
	71	263.0	344	725	080	20:1	100LA-4
	63	297.0	415	826	080	15:1	112M-6
	47	367.0	395	920	080	30:1	100LA-4
3.00	47	393.0	399	725	080	20:1	112M-6
	141	191.0	297	625	080	10:1	100LB-4
	94	277.0	352	826	080	15:1	100LB-4
4.00	381	95.2	196	695	080	7.5:1	112M-2
	286	126.0	197	625	080	10:1	112M-2
	284	131.0	250	610	080	5:1	112M-4
	216	165.0	173	321	080	13.25:1	112M-2
	189	192.0	289	695	080	7.5:1	112M-4
	142	253.0	297	625	080	10:1	112M-4
	95	366.0	382	826	080	15:1	112M-4

## Permissible radial force F<sub>r2</sub> and axial force F<sub>a2</sub> on shaft N<sub>2</sub>

n <sub>2</sub> [rpm]	200		125		75		50		30		10		
	T <sub>2</sub> [Nm]	F <sub>r</sub> [N]	F <sub>a</sub> [N]	F <sub>r</sub> [N]	F <sub>a</sub> [N]	F <sub>r</sub> [N]	F <sub>a</sub> [N]	F <sub>r</sub> [N]	F <sub>a</sub> [N]	F <sub>r</sub> [N]	F <sub>a</sub> [N]	F <sub>r</sub> [N]	F <sub>a</sub> [N]
< 430		3300	1650	3750	1875	4500	2250	5300	2650	6300	3150	7600	3800
> 430		2640	1320	3000	1500	3600	1800	4240	2120	5040	2520	6080	3040

The mass inertia moment and the weight of the motor depend on the manufacturer. Please enquire the values of the overall system. For the dimensions of the worm gearbox, please refer to chapter 8.3 Worm gearboxes

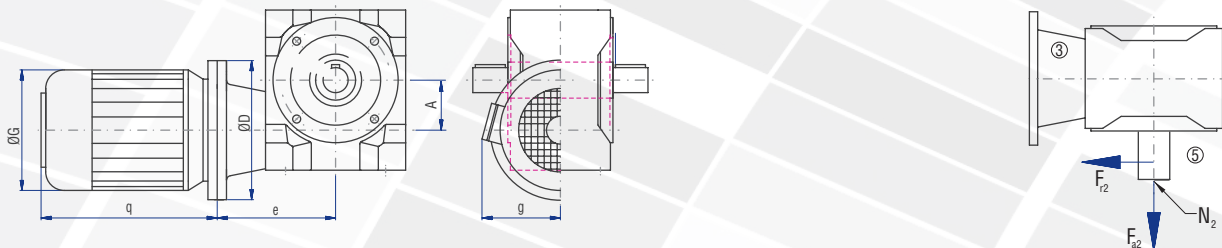

IEC motor	D [mm]	G [mm]	g [mm]	q [mm]	q <sub>1</sub> [mm]	e [mm]	A [mm]
080	160	170	126	234	245	183	80
90L	200	185	142	272	298	195	80
90S	200	185	142	247	273	195	80
100	200	210	155	301	348	195	80
112	200	210	155	301	348	195	80

The value q<sub>1</sub> applies to braking motors

## 10.4.10 Type SLM 100 – Type SL with motor (gearbox motor)

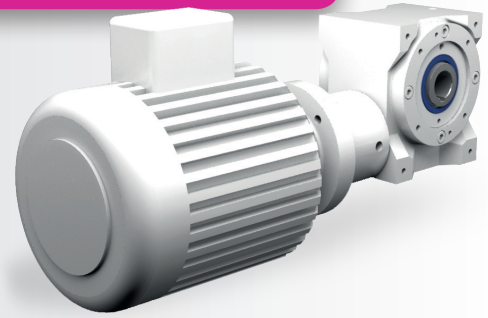

### Characteristics

Characteristic	Standard	Option
<b>Toothing</b>	Hardened and ground worm shaft / bronze worm gear	See chapter 9.2.1
<b>Gear ratio</b>	5:1 to 83:1	
<b>Housing / Flanges</b>	Grey cast iron	
<b>Threaded mounting hole</b>	On gearbox side 1 and on the flanges	See chapter 9.2.3
<b>Shaft</b>	Material 1 C45, shaft ends greased Fit with ISO j6 tolerance with parallel keyway: according to DIN 6885 Sheet 1	See chapter 4.6.2
<b>Hollow shaft</b>	Material 1 C45, shafts greased Fit with ISO H7 tolerance with parallel keyway: according to DIN 6885 Sheet 1	See chapter 4.6.3
<b>Radial shaft seal ring</b>	NBR, form A	See chapter 4.8
<b>Ambient temperature</b>	-10°C to +90°C. The values of the performance tables are valid for +20°C	See chapter 4.9.3
<b>Circumferential backlash</b>	< 30 arcmin	See chapter 9.2.10
<b>Protection classes</b>	IP 54	See chapter 4.5
<b>Corrosion protection</b>	Prime coat; layer thickness > 40 µm	See chapter 4.4.1
<b>Bearing life L10h</b>	more than 15,000h	See chapter 4.9.1
<b>Oil change intervals</b>	Not required if the oil temperature is kept < 90°C The lifetime of the bearings can be increased by the factor 1.5 if the oil is changed after the first 500 service hours and then every 5000 service hours.	See chapter 9.2.8
<b>Lubricants</b>	Synthetic lubricants	See chapter 9.2.8
<b>Motor</b>	IEC standard motor in the prescribed efficiency class	

For the dimensions of the worm gearbox, please refer to chapter 9.3.10 Standard worm gearboxes, page 203



## Performance data

P <sub>1</sub> [kW]	n <sub>2</sub> [rpm]	T <sub>2</sub> [Nm]	T <sub>2N</sub> [Nm]	T <sub>2 max</sub> [Nm]	Gearbox size	i [-]	IEC motor
0.75	18	295.0	704	1080	100	52:1	090S-6
	14	348.0	886	1040	100	63:1	090S-6
	13	397.0	728	1080	100	52:1	100LA-8
	11	404.0	599	1000	100	82:1	090S-6
	11	423.0	886	1040	100	63:1	100LA-8
	8	546.0	599	1000	100	82:1	100LA-8
1.10	27	300.0	670	1080	100	52:1	090S-4
	22	334.0	817	1040	100	63:1	090S-4
	18	432.0	704	1080	100	52:1	090L-6
	17	408.0	599	1000	100	82:1	090S-4
	14	510.0	886	1040	100	63:1	090L-6
	13	582.0	728	1080	100	52:1	100LB-8
	11	592.0	599	1000	100	82:1	090L-6
1.50	11	621.0	886	1040	100	63:1	100LB-8
	53	235.0	605	980	100	26:1	090L-4
	35	348.0	634	980	100	26:1	100LA-6
	27	409.0	670	1080	100	52:1	090L-4
	23	486.0	933	1582	100	40:1	100LA-6
	23	486.0	950	1765	100	30:1	112M-8
	22	456.0	817	1040	100	63:1	090L-4
	18	589.0	704	1080	100	52:1	100LA-6
	18	605.0	1025	1528	100	40:1	112M-8
	17	556.0	599	1000	100	82:1	090L-4
	15	649.0	886	1040	100	63:1	100LA-6
2.20	11	847.0	886	1040	100	63:1	112M-8
	54	339.0	605	980	100	26:1	100LA-4
	47	367.0	748	1765	100	30:1	100LA-4
	36	496.0	634	980	100	26:1	112M-6
	35	480.0	817	1582	100	40:1	100LA-4
	31	542.0	825	1765	100	30:1	112M-6
	27	599.0	670	1080	100	52:1	100LA-4
	24	683.0	933	1582	100	40:1	112M-6
	24	683.0	950	1765	100	30:1	132SB-8
	22	669.0	817	1040	100	63:1	100LA-4
18	887.0	1025	1582	100	40:1	132SB-8	

P <sub>1</sub> [kW]	n <sub>2</sub> [rpm]	T <sub>2</sub> [Nm]	T <sub>2N</sub> [Nm]	T <sub>2 max</sub> [Nm]	Gearbox size	i [-]	IEC motor
3.00	127	212.0	743	1360	100	7.5:1	132SB-6
	108	244.0	464	736	100	13:1	100LB-4
	71	359.0	778	1440	100	20:1	100LB-4
	63	405.0	817	1610	100	15:1	132SB-6
	54	462.0	605	980	100	26:1	100LB-4
	47	500.0	748	1765	100	30:1	100LB-4
	35	655.0	817	1582	100	40:1	100LB-4
	24	931.0	933	1582	100	40:1	132SB-6
	24	931.0	950	1765	100	30:1	132MB-8
	127	283.0	743	1360	100	7.5:1	132MA-6
4.00	109	322.0	464	736	100	13:1	112M-4
	95	362.0	715	1610	100	15:1	112M-4
	71	479.0	778	1440	100	20:1	112M-4
	63	540.0	817	1610	100	15:1	132MA-6
	55	604.0	605	980	100	26:1	112M-4
	47	666.0	748	1765	100	30:1	112M-4
	387	128.0	211	1360	100	7.5:1	132SA-2
	290	170.0	555	1090	100	10:1	132SA-2
	286	176.0	590	1190	100	5:1	132SB-4
	223	217.0	427	736	100	13:1	132SA-2
5.50	191	259.0	650	1360	100	7.5:1	132SB-4
	143	345.0	703	1090	100	10:1	132SB-4
	127	389.0	743	1360	100	7.5:1	132MB-6
	110	439.0	464	736	100	13:1	132SB-4
	95	497.0	715	1610	100	15:1	132SB-4
	72	649.0	778	1440	100	20:1	132SB-4
	63	742.0	817	1610	100	15:1	132MB-6
	580	119.0	450	1190	100	5:1	132SB-2
	387	174.0	513	1360	100	7.5:1	132SB-2
	290	232.0	555	1090	100	10:1	132SB-2
7.50	286	240.0	590	1190	100	5:1	132MB-4
	223	296.0	427	736	100	13:1	132SB-2
	143	471.0	703	1090	100	10:1	132MB-4
	95	679.0	715	1610	100	15:1	132MB-4
	582	142.0	450	1190	100	5:1	132MA-2
	388	208.0	513	1360	100	7.5:1	132MA-2
	291	278.0	555	1090	100	10:1	132MA-2
	224	353.0	427	736	100	13:1	132MA-2

Gearbox motors

## Permissible radial force F<sub>r2</sub> and axial force F<sub>a2</sub> on shaft N<sub>2</sub>

n <sub>2</sub> [rpm]	200		125		75		50		30		10		
	T <sub>2</sub> [Nm]	F <sub>r</sub> [N]	F <sub>a</sub> [N]	F <sub>r</sub> [N]	F <sub>a</sub> [N]	F <sub>r</sub> [N]	F <sub>a</sub> [N]	F <sub>r</sub> [N]	F <sub>a</sub> [N]	F <sub>r</sub> [N]	F <sub>a</sub> [N]		
< 800		3650	1825	4000	2000	4750	2375	5600	2800	6700	3350	9500	4750
> 800		2920	1460	3200	1600	3800	1900	4480	2240	5360	2680	7600	3800

The mass inertia moment and the weight of the motor depend on the manufacturer. Please enquire the values of the overall system. For the dimensions of the worm gearbox, please refer to chapter 8.3 Worm gearboxes

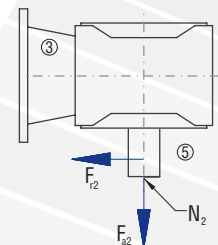
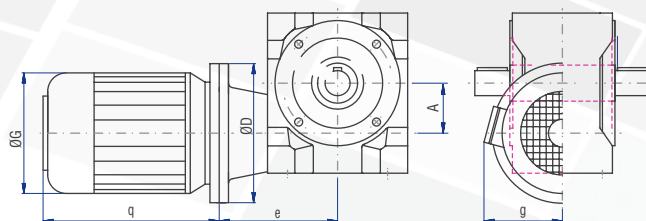

IEC motor	D [mm]	G [mm]	g [mm]	q [mm]	q <sub>1</sub> [mm]	e [mm]	A [mm]
90L	200	185	142	272	298	235	100
90S	200	185	142	247	273	235	100
100	250	210	155	301	348	245	100
112	250	210	155	301	348	245	100
132M	300	260	200	416	454	265	100
132S	300	260	200	390	428	265	100

The value q<sub>1</sub> applies to braking motors

**ATEK**  
ANTRIEBSTECHNIK

## 10.4.11 Type SLM 125 – Type SL with motor (gearbox motor)

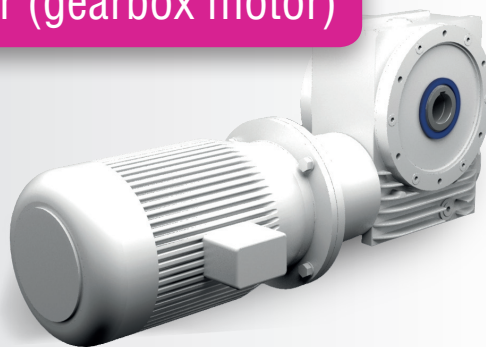

### Characteristics

Characteristic	Standard	Option
<b>Toothing</b>	Hardened and ground worm shaft / bronze worm gear	See chapter 9.2.1
<b>Gear ratio</b>	5:1 to 83:1	
<b>Housing / Flanges</b>	Grey cast iron	
<b>Threaded mounting hole</b>	On gearbox sides 1, 2 and on the flanges	See chapter 9.2.3
<b>Shaft</b>	Material 1 C45, shaft ends greased Fit with ISO j6 tolerance with parallel keyway: according to DIN 6885 Sheet 1	See chapter 4.6.2
<b>Hollow shaft</b>	Material GGG grey cast iron, shafts greased Fit with ISO H7 tolerance with parallel keyway: according to DIN 6885 Sheet 1	See chapter 4.6.3
<b>Radial shaft seal ring</b>	NBR, form A	See chapter 4.8
<b>Ambient temperature</b>	-10°C to +90°C. The values of the performance tables are valid for +20°C	See chapter 4.9.3
<b>Circumferential backlash</b>	< 30 arcmin	See chapter 9.2.10
<b>Protection classes</b>	IP 54	See chapter 4.5
<b>Corrosion protection</b>	Prime coat; layer thickness > 40 µm	See chapter 4.4.1
<b>Bearing life L10h</b>	more than 15,000h	See chapter 4.9.1
<b>Oil change intervals</b>	Not required if the oil temperature is kept < 90°C The lifetime of the bearings can be increased by the factor 1.5 if the oil is changed after the first 500 service hours and then every 5000 service hours.	See chapter 9.2.8
<b>Lubricants</b>	Synthetic lubricants	See chapter 9.2.8
<b>Motor</b>	IEC standard motor in the prescribed efficiency class	

For the dimensions of the worm gearbox, please refer to chapter 9.3.11 Standard worm gearboxes, page 207



## 10.4.12 Type SLM 160 – Type SL with motor (gearbox motor)

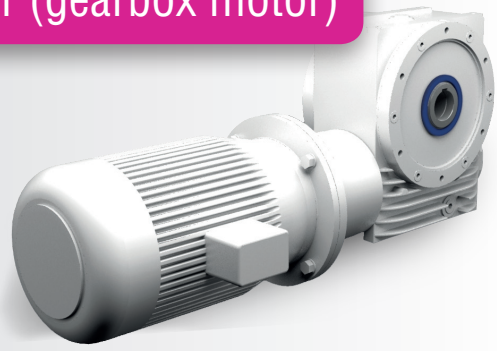

### Characteristics

Characteristic	Standard	Option
<b>Toothing</b>	Hardened and ground worm shaft / bronze worm gear	See chapter 9.2.1
<b>Gear ratio</b>	5:1 to 83:1	
<b>Housing / Flanges</b>	Grey cast iron	
<b>Threaded mounting hole</b>	On gearbox sides 1, 2 and on the flanges	See chapter 9.2.3
<b>Shaft</b>	Material 1 C45, shaft ends greased Fit with ISO j6 tolerance with parallel keyway: according to DIN 6885 Sheet 1	See chapter 4.6.2
<b>Hollow shaft</b>	Material GGG grey cast iron, shafts greased Fit with ISO H7 tolerance with parallel keyway: according to DIN 6885 Sheet 1	See chapter 4.6.3
<b>Radial shaft seal ring</b>	NBR, form A	See chapter 4.8
<b>Ambient temperature</b>	-10°C to +90°C. The values of the performance tables are valid for +20°C	See chapter 4.9.3
<b>Circumferential backlash</b>	< 30 arcmin	See chapter 9.2.10
<b>Protection classes</b>	IP 54	See chapter 4.5
<b>Corrosion protection</b>	Prime coat; layer thickness > 40 µm	See chapter 4.4.1
<b>Bearing life L10h</b>	more than 15,000h	See chapter 4.9.1
<b>Oil change intervals</b>	Not required if the oil temperature is kept < 90°C The lifetime of the bearings can be increased by the factor 1.5 if the oil is changed after the first 500 service hours and then every 5000 service hours.	See chapter 9.2.8
<b>Lubricants</b>	Synthetic lubricants	See chapter 9.2.8
<b>Motor</b>	IEC standard motor in the prescribed efficiency class	

For the dimensions of the worm gearbox, please refer to chapter 9.3.12 Standard worm gearboxes, page 211

## Performance data

P <sub>1</sub> [kW]	n <sub>2</sub> [rpm]	T <sub>2</sub> [Nm]	T <sub>2N</sub> [Nm]	T <sub>2 max</sub> [Nm]	Gearbox size	i [-]	IEC motor
3.00	18	1273.0	2494	3700	160	54:1	132SB-6
	15	1413.0	2591	3900	160	63:1	132SB-6
	13	1719.0	2582	3700	160	54:1	132MB-8
	11	1823.0	2347	4050	160	84:1	132SB-6
4.00	32	1003.0	2678	4500	160	30:1	132MA-6
	26	1190.0	2372	3700	160	54:1	112M-4
	24	1305.0	2735	5120	160	40:1	132MA-6
	23	1246.0	2266	3900	160	63:1	112M-4
	18	1698.0	2494	3700	160	54:1	132MA-6
	17	1618.0	2347	4050	160	84:1	112M-4
	15	1885.0	2591	3900	160	63:1	132MA-6
	13	2292.0	2582	3700	160	54:1	132MA-6
5.50	11	2535.0	2848	3900	160	63:1	160MA-8
	48	919.0	2170	4500	160	30:1	132SB-4
	36	1211.0	2267	5120	160	40:1	132SB-4
	35	1321.0	2231	3345	160	27:1	132MB-6
	32	1379.0	2678	4500	160	30:1	132MB-6
	26	1636.0	2372	3700	160	54:1	132SB-4
	24	1795.0	2735	5120	160	40:1	132MB-6
	23	1713.0	2266	3900	160	63:1	132SB-4
	18	2334.0	2494	3700	160	54:1	132MB-6
	18	2364.0	3190	5120	160	40:1	160LA-8
	17	2225.0	2347	4050	160	84:1	132SB-4
	15	2591.0	2591	3900	160	63:1	132MB-6
7.50	95	694.0	1970	4550	160	15:1	132MB-4
	72	895.0	2158	5050	160	20:1	132MB-4
	64	1030.0	2386	4550	160	15:1	160MB-6
	53	1203.0	2124	3345	160	27:1	132MB-4
	48	1253.0	2170	4500	160	30:1	132MB-4
	36	1651.0	2267	5120	160	40:1	132MB-4
	32	1880.0	2678	4500	160	30:1	160MB-6
	26	2231.0	2372	3700	160	54:1	132MB-4
24	2447.0	2735	5120	160	40:1	160MB-6	

P <sub>1</sub> [kW]	n <sub>2</sub> [rpm]	T <sub>2</sub> [Nm]	T <sub>2N</sub> [Nm]	T <sub>2 max</sub> [Nm]	Gearbox size	i [-]	IEC motor
9.00	95	832.0	1970	4550	160	15:1	132MC-4
	72	1074.0	2158	5050	160	20:1	132MC-4
	53	1443.0	2124	3345	160	27:1	132MC-4
	48	1504.0	2170	4500	160	30:1	132MC-4
	36	1982.0	2267	5120	160	40:1	132MC-4
11.00	147	679.0	1951	4780	160	10:1	160MB-4
	128	788.0	2051	4450	160	7.5:1	160LA-6
	109	906.0	1600	2410	160	13.5:1	160MB-4
	98	986.0	1970	4550	160	15:1	160MB-4
	73	1295.0	2158	5050	160	20:1	160MB-4
	64	1510.0	2386	4550	160	15:1	160LA-6
	54	1731.0	2124	3345	160	27:1	160MB-4
15.00	49	1801.0	2170	4500	160	30:1	160MB-4
	48	1970.0	2467	5050	160	20:1	160LA-6
	391	348.0	996	4450	160	7.5:1	160MB-2
	293	474.0	1640	4450	160	5:1	160LA-4
	217	621.0	1466	2410	160	13.5:1	160MB-2
	195	698.0	1793	4450	160	7.5:1	160LA-4
	147	926.0	1951	4780	160	10:1	160LA-4
	129	1066.0	2051	4450	160	7.5:1	180L-6
	109	1235.0	1600	2410	160	13.5:1	160LA-4
	98	1345.0	1970	4550	160	15:1	160LA-4
	73	1766.0	2158	5050	160	20:1	160LA-4
	65	2028.0	2386	4550	160	15:1	180L-6
18.50	392	428.0	996	4450	160	7.5:1	160L-2
	294	583.0	1640	4450	160	5:1	180M-4
	218	762.0	1466	2410	160	13.5:1	160L-2
	196	856.0	1793	4450	160	7.5:1	180M-4
	147	1142.0	1951	4780	160	10:1	180M-4
	109	1524.0	1600	2410	160	13.5:1	180M-4
	98	1659.0	1970	4550	160	15:1	180M-4
	74	2149.0	2158	5050	160	20:1	180M-4
	294	693.0	1640	4450	160	5:1	180L-4
	196	1018.0	1793	4450	160	7.5:1	180L-4
147	1358.0	1951	4780	160	10:1	180L-4	

Gearbox motors

## Permissible radial force F<sub>r2</sub> and axial force F<sub>a2</sub> on shaft N<sub>2</sub>

n <sub>2</sub> [rpm]	200		125		75		50		30		10		
	T <sub>2</sub> [Nm]	F <sub>r</sub> [N]	F <sub>a</sub> [N]	F <sub>r</sub> [N]	F <sub>a</sub> [N]	F <sub>r</sub> [N]	F <sub>a</sub> [N]	F <sub>r</sub> [N]	F <sub>a</sub> [N]	F <sub>r</sub> [N]	F <sub>a</sub> [N]	F <sub>r</sub> [N]	F <sub>a</sub> [N]
< 2300		5600	2800	6800	3400	7600	3800	8600	4300	10200	5100	13600	6800
> 2300		4670	2335	5670	2835	6330	3165	7170	3585	8500	4250	11300	5650

The mass inertia moment and the weight of the motor depend on the manufacturer. Please enquire the values of the overall system. For the dimensions of the worm gearbox, please refer to chapter 8.3 Worm gearboxes

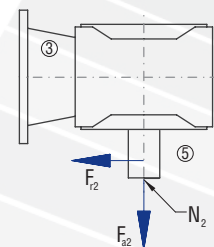
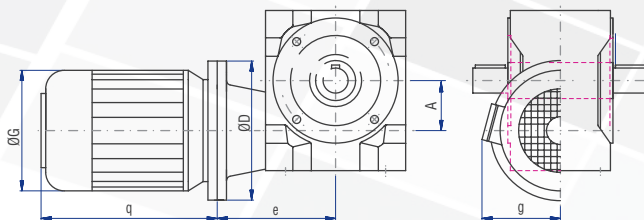

IEC motor	D [mm]	G [mm]	g [mm]	q [mm]	q <sub>1</sub> [mm]	e [mm]	A [mm]
112	250	210	155	301	348	310	160
132M	300	260	200	416	454	340	160
132S	300	260	200	390	428	340	160
160	350	320	245	540	0	370	160
180	350	320	245	580	0	370	160

The value q<sub>1</sub> applies to braking motors

## 10.4.13 Type SLM 200 – Type SL with motor (gearbox motor)

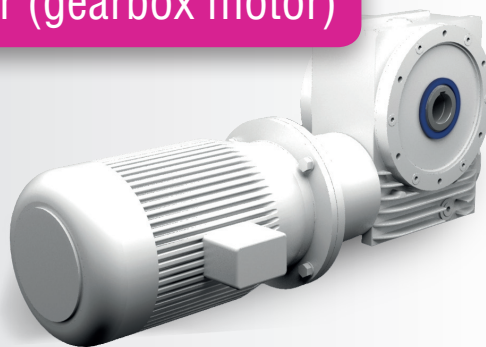

### Characteristics

Characteristic	Standard	Option
<b>Toothing</b>	Hardened and ground worm shaft / bronze worm gear	See chapter 9.2.1
<b>Gear ratio</b>	5:1 to 83:1	
<b>Housing / Flanges</b>	Grey cast iron	
<b>Threaded mounting hole</b>	On gearbox sides 1, 2 and on the flanges	See chapter 9.2.3
<b>Shaft</b>	Material 1 C45, shaft ends greased Fit with ISO j6 tolerance with parallel keyway: according to DIN 6885 Sheet 1	See chapter 4.6.2
<b>Hollow shaft</b>	Material GGG grey cast iron, shafts greased Fit with ISO H7 tolerance with parallel keyway: according to DIN 6885 Sheet 1	See chapter 4.6.3
<b>Radial shaft seal ring</b>	NBR, form A	See chapter 4.8
<b>Ambient temperature</b>	-10°C to +90°C. The values of the performance tables are valid for +20°C	See chapter 4.9.3
<b>Circumferential backlash</b>	< 30 arcmin	See chapter 9.2.10
<b>Protection class</b>	IP 54	See chapter 4.5
<b>Corrosion protection</b>	Prime coat; layer thickness > 40 µm	See chapter 4.4.1
<b>Bearing life L10h</b>	more than 15,000h	See chapter 4.9.1
<b>Oil change intervals</b>	Not required if the oil temperature is kept < 90°C The lifetime of the bearings can be increased by the factor 1.5 if the oil is changed after the first 500 service hours and then every 5000 service hours.	See chapter 9.2.8
<b>Lubricants</b>	Synthetic lubricants	See chapter 9.2.8
<b>Motor</b>	IEC standard motor in the prescribed efficiency class	

For the dimensions of the worm gearbox, please refer to chapter 9.3.12 Standard worm gearboxes, page 215



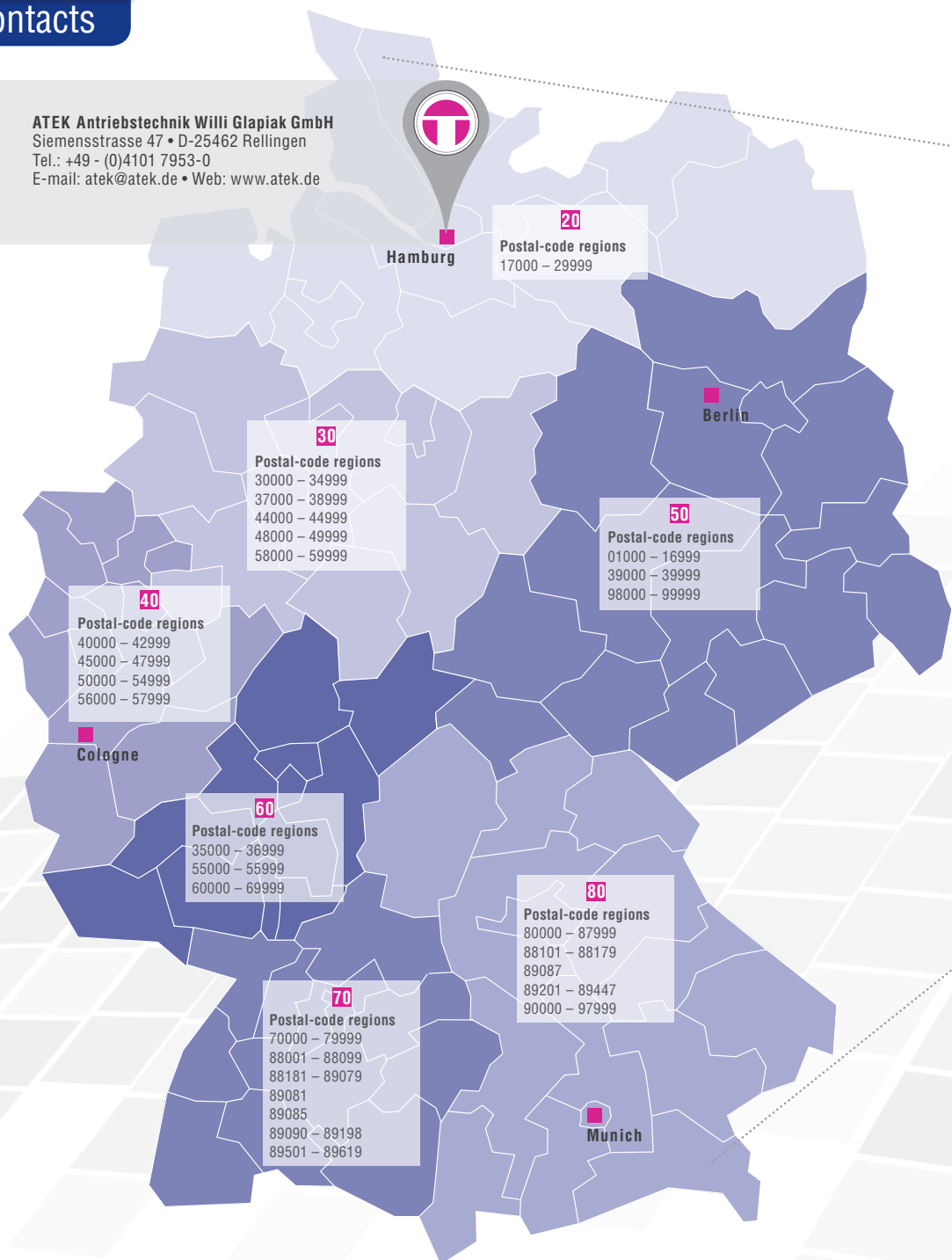

## ATEK in Germany

**20 HEINRICH WOLF GmbH & Co. KG**  
 Albert-Einstein-Str. 12  
 23701 Eutin  
 Tel.: +49 4521 79677-0  
 Fax: +49 4521 79677-29  
 info@wolf-eutin.de  
 www.wolf-eutin.de

**40 Hasske und Meermann  
 Antriebstechnik GmbH**  
 Forststrasse 51  
 40721 Hilden  
 Tel.: +49 2103 5821-0  
 Fax: +49 2103 5821-25  
 hi@hasskeundmeermann.de  
 www.hasskeundmeermann.de

**60 Bretzel GmbH**  
**Antriebs- und Elektrotechnik**  
 Am Rotböhl 8  
 64331 Weiterstadt  
 Tel.: +49 6150 86560-0  
 Fax: +49 6150 86560-69  
 info@bretzel-gmbh.de  
 www.bretzel-gmbh.de

**80 KW Antriebs- &  
 Automationstechnik GmbH**  
 Koberger Str. 39  
 90408 Nürnberg  
 Tel.: +49 911 3663369-0  
 Fax: +49 911 3663369-15  
 info@kw-antriebstechnik.de  
 www.kw-antriebstechnik.de

**30 INFRA Antriebe Hans Nelk GmbH**  
 Alter Kirchpfad 6  
 32657 Lemgo  
 Tel.: +49 5261 3445  
 Fax: +49 5261 15641  
 info@infra-antriebe.de  
 www.infra-antriebe.de

**50 Hasske und Meermann  
 Antriebstechnik GmbH**  
 Kolpingstraße 42  
 08058 Zwickau  
 Tel.: +49 375 216708  
 Fax: +49 375 2049199  
 zw@hasskeundmeermann.de  
 www.hasskeundmeermann.de

**70 B&K Antriebstechnik GmbH**  
 Anhauser Str. 76  
 89547 Gerstetten-Dettingen  
 Tel.: +49 7324 91012-0  
 Fax: +49 7324 91012-25  
 info@b-k-antriebstechnik.de  
 www.b-k-antriebstechnik.de



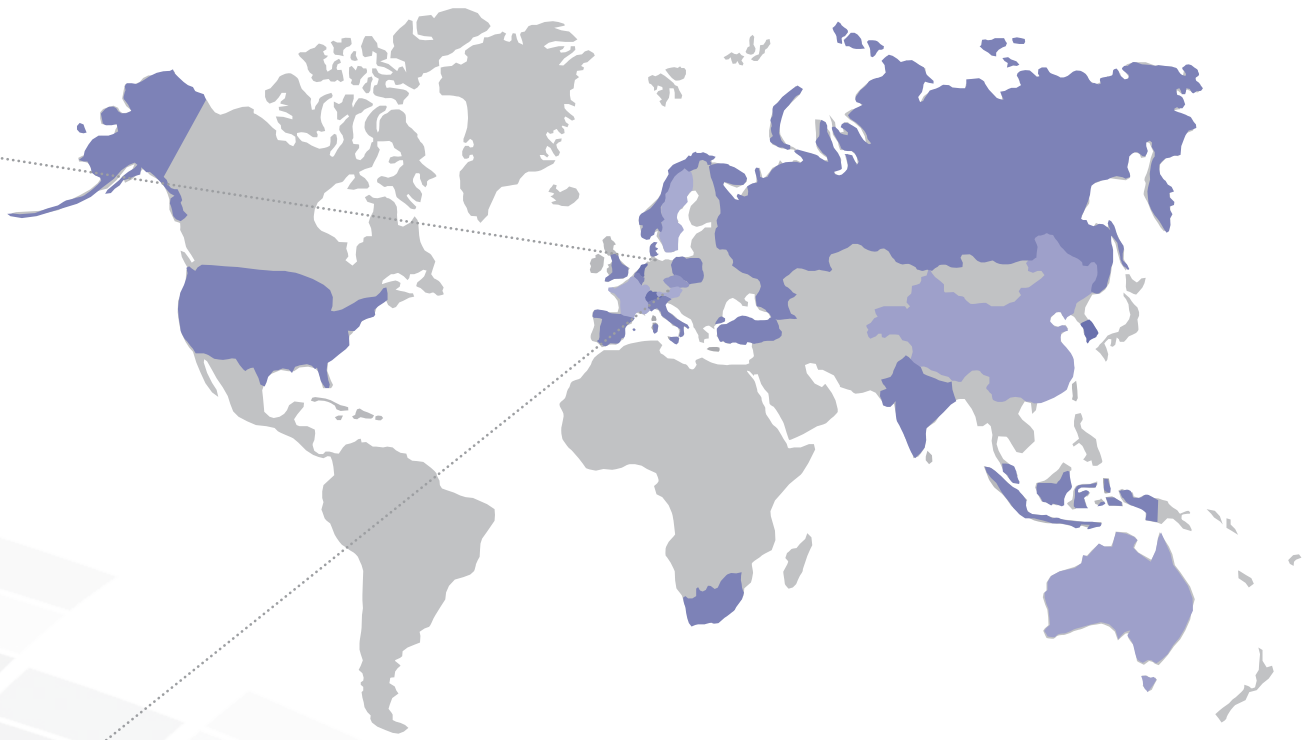

## ATEK worldwide

**Australia**  
**Mecco Mech. Comp. PTY Ltd.**  
 193 Orange Valley Road  
 6076 Kalamunda  
 Tel.: +61 89 2910000  
 Fax: +61 89 2910066  
 mecccomps@gmail.com  
 www.mecco.com.au

**Belgium**  
**Bege Aandrijftechniek BVBA**  
 Puifestraat 73  
 2940 Stabroek  
 Tel.: +32 36 051605  
 Fax: +32 36 053605  
 bege@bege.be  
 www.bege.be

**United Kingdom**  
**Marshward Power Transmission Ltd.**  
 Unit 9, Warwick House  
 Business Park  
 Southam  
 CV472PT Warwickshire  
 Tel.: +44 1926 815480  
 Fax: +44 1926 817116  
 www.marshward.com  
 info@marshward.com

**France**  
**Comp'Aut. Sarl**  
 78 rue Carnot  
 74000 Annecy  
 Tel.: +33 45057 0791  
 Fax: +33 45057 2145  
 contact@compaut.com  
 www.compaut.com

**India**  
**Power Ace Eng. Co.**  
 17AF, New Empire Ind. Estate  
 Kondivita Lane, J. B. Nagar  
 Andheri(e), Mumbai  
 400059 Mumbai  
 Tel.: +91 22 28205862  
 Fax: +91 22 28202478  
 response@poweraceindia.com  
 www.poweraceindia.com

**Italy**  
**SETEC S.p.A.**  
 Via Mappano 17  
 10071 Borgaro Torinese Torino  
 Tel.: +39 011 4518611  
 Fax: +39 011 4704891  
 info.to@setec-group.it  
 www.setec-group.it

**Netherlands**  
**Bege Aandrijftechniek B.V.**  
 Anton Philipsweg 30  
 2171 KX Sassenheim  
 Tel.: +31 252 220220  
 Fax: +31 252 218484  
 bege@bege.nl  
 www.bege.nl

**Norway**  
**Centa Transmisjoner A.S.**  
 Breiliveien 49  
 3217 Sandefjord  
 Tel.: +47 334 83100  
 Fax: +47 334 83110  
 centa@centa.no  
 www.centa.no

**Poland**  
**DEMERO SP.j.**  
 Ul. Graniczna 145  
 54-530 Wroclaw  
 Tel.: +48 71 3882300  
 Fax: +48 71 3882311  
 biuro@demero.pl  
 www.demero.pl

**Russia**  
**Stankoservice-Sokol 000**  
 ul. Tschasowaya 28, Building 4  
 125315 Moscow  
 Tel.: +7 49 52251339  
 Fax: +7 49 52251339  
 info@stserv.ru  
 www.stserv.ru

**Sweden**  
**Nord Drivsystem AB**  
 Ryttagatan 277  
 19471 Upplands Väsby  
 Tel.: +46 859 411400  
 Fax: +46 859 411414  
 info@nord-se.com  
 www.nord.com

**Switzerland**  
**Flohr Industrietechnik GmbH**  
 Zilistude 164  
 5465 Mellikon  
 Tel.: +41 56 2670810  
 Fax: +41 56 2670825  
 info@flohr-industrietechnik.ch  
 www.flohr-industrietechnik.ch

**South Africa**  
**Remag (Pty) Ltd.**  
 Midway Park  
 770 Gallagher Avenue  
 1685 Midrand  
 Tel.: +27 11 3155672  
 Fax: +27 11 3155570  
 eric.rehme@remag.co.za

**Spain**  
**Amel Tecnica Industrial S.L.**  
**Pol. Ind. Can Bernades-Subirá**  
 C/ Berguedá 15 Nave 17 B  
 08130 Santa Perpétua de la Mogoda  
 Tel.: +34 937 162424  
 Fax: +34 937 162458  
 xcomas@ameltecnica.com

**South Korea**  
**Alpha Tech Co., LTD**  
 222-26, Mae-dong, Ojung-Ku  
 421-806 Bucheon-City, Kyunggi-Do  
 Tel.: +82 32 6243848  
 Fax: +82 32 6243849  
 tklee64@hanafos.com

**Czech Republic**  
**RAVED s.r.o.**  
 Trida Tomase Bati 1851  
 76502 Otrokovice  
 Tel.: +42 05 77663875  
 Fax: +42 05 77663875  
 info@raveo.cz  
 www.raveo.cz

**Turkey**  
**Servo Kontrol Ltd. Sti**  
 Perpa Ticaret Merkezi B Blok Kat: 11  
 No: 1609  
 80270 Okmeydani/ Istanbul  
 Tel.: +90 212 320 30 80  
 Fax: +90 212 320 30 81  
 info@servokontrol.com  
 www.servokontrol.com

**USA**  
**GAM Gear, L.L.C.**  
 901 E. Business Center Drive  
 60056 Mount Prospect, Illinois  
 Tel.: +1 - 847 / 649 2500  
 Fax: +1 - 847 / 649 2501  
 info@gamweb.com  
 www.gamweb.com

**People's Republic of China**  
**SEW-Eurodrive (Tianjin) Co Ltd.**  
 No. 78, 13th Avenue Tianjin Economic  
 Technological Development Area (TEDA)  
 Tianjin 300457  
 Tel.: +86 22 59836655  
 Fax: +86 22 59836651  
 info@sew-eurodrive.com.cn  
 www.sew-eurodrive.com.cn

**Beijing Genju Science and Technology Development Co Ltd.**  
 Jin Gu Mansions, No. 55,  
 Tanbo Center, Room 206 No. 30  
 Xingshikou Road, Haidian District,  
 Beijing 100195  
 Tel.: +86 10 88459170  
 Fax: +86 10 88454543  
 info@genju.com.cn  
 www.genju.com.cn

**Singapore, Malaysia, Indonesia**  
**SM Component**  
 196 Pandan Loop #05-06  
 Pantech Industrial Complex  
 Singapore 128384  
 Tel.: +65 6569 1110  
 Fax: +65 6569 2220  
 sales@sm-component.com